



**RPM**  
x1000

# **BIG END™**

**PERFORMANCE PRODUCTS**

**RACING AND PERFORMANCE  
EQUIPMENT CATALOG**

# **BIG END**

**PERFORMANCE PRODUCTS**

## **TABLE OF CONTENTS**

<b>2</b>	<b>PERFORMANCE PLUMBING</b>
<b>11</b>	<b>FUEL DELIVERY</b>
<b>17</b>	<b>POWER ADDERS</b>
<b>20</b>	<b>GAUGES</b>
<b>23</b>	<b>BODY AND SAFETY</b>
<b>27</b>	<b>DRIVELINE</b>
<b>32</b>	<b>CHASSIS AND SUSPENSION</b>
<b>33</b>	<b>CHEMICALS AND ADDITIVES</b>
<b>34</b>	<b>ENGINE COMPONENTS</b>
<b>40</b>	<b>GASKETS</b>
<b>42</b>	<b>COOLING</b>
<b>45</b>	<b>ELECTRICAL AND IGNITION</b>
<b>51</b>	<b>DRESS-UP</b>
<b>54</b>	<b>EXHAUST</b>
<b>55</b>	<b>HEAT PROTECTION</b>
<b>56</b>	<b>PRODUCT INDEX</b>
<b>58</b>	<b>PART NUMBER INDEX</b>

### ALUMINUM HOSE ENDS

- Constructed from lightweight 6061 alloy aluminum
- Designed for smooth flow, easy assembly and longer life
- Elbow ends built from one-piece billet-tube construction
- Viton O-ring seal allows 360° rotation
- 37° AN flare assures a leak proof seal
- Compatible with all AN adapter fittings



### STRAIGHT SWIVEL

Red/Blue			Black		
BEP12400	-4 AN	<b>NEW!</b>	BEP14400	-4 AN	<b>NEW!</b>
BEP12600	-6 AN		BEP14600	-6 AN	
BEP12800	-8 AN		BEP14800	-8 AN	
BEP12000	-10 AN		BEP14000	-10 AN	
BEP12200	-12 AN		BEP14200	-12 AN	
BEP12500	-16 AN		BEP14500	-16 AN	

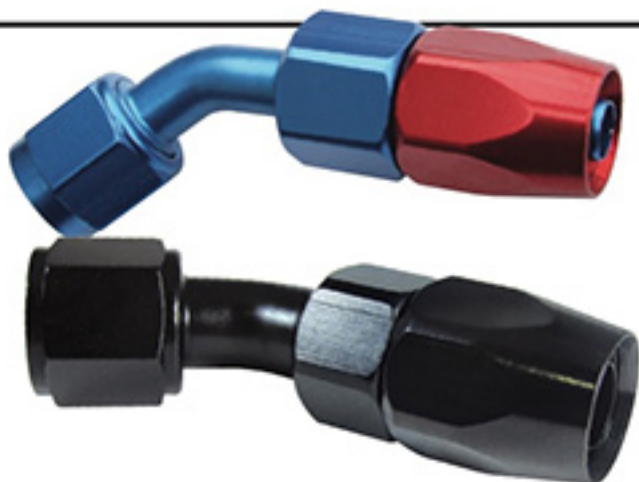

### 45 DEGREE ELBOW

Red/Blue			Black		
BEP12445	-4 AN	<b>NEW!</b>	BEP14445	-4 AN	<b>NEW!</b>
BEP12645	-6 AN		BEP14645	-6 AN	
BEP12845	-8 AN		BEP14845	-8 AN	
BEP12045	-10 AN		BEP14045	-10 AN	
BEP12245	-12 AN		BEP14245	-12 AN	
BEP12545	-16 AN		BEP14545	-16 AN	



### 90 DEGREE ELBOW

Red/Blue			Black		
BEP12490	-4 AN	<b>NEW!</b>	BEP14490	-4 AN	<b>NEW!</b>
BEP12690	-6 AN		BEP14690	-6 AN	
BEP12890	-8 AN		BEP14890	-8 AN	
BEP12090	-10 AN		BEP14090	-10 AN	
BEP12290	-12 AN		BEP14290	-12 AN	
BEP12590	-16 AN		BEP14590	-16 AN	



### 120 DEGREE ELBOW

Red/Blue			Black		
BEP12602	-6 AN		BEP14602	-6 AN	
BEP12802	-8 AN		BEP14802	-8 AN	
BEP12002	-10 AN		BEP14002	-10 AN	
BEP12202	-12 AN		BEP14202	-12 AN	
BEP12502	-16 AN		BEP14502	-16 AN	





**150 DEGREE ELBOW**

Red/Blue		Black	
BEP12604	-6 AN	BEP14604	-6 AN
BEP12804	-8 AN	BEP14804	-8 AN
BEP12004	-10 AN	BEP14004	-10 AN
BEP12204	-12 AN	BEP14204	-12 AN
BEP12504	-16 AN	BEP14504	-16 AN

**180 DEGREE ELBOW**

Red/Blue		Black	
BEP12680	-6 AN	BEP14680	-6 AN
BEP12880	-8 AN	BEP14880	-8 AN
BEP12080	-10 AN	BEP14080	-10 AN
BEP12280	-12 AN	BEP14280	-12 AN
BEP12580	-16 AN	BEP14580	-16 AN

HOSE NOT INCLUDED. SEE PAGE 5.



**HOSE ASSEMBLY TOOLS**

- Precision tool that installs rubber and stainless steel braided hose on the fitting

- BEP41300 Small Kit (-4, -6, -8 AN)
- BEP41305 Large Kit (-10, -12, -16 AN)
- BEP41310 Hot Rod Kit (-6, -8, -10 AN)
- BEP41315 Pro Combo Kit (-4, -6, -8, -10, -12, -16 AN)
- BEP41320 -6 AN Kit
- BEP41321 -8 AN Kit
- BEP41322 -10 AN Kit



**BILLET AN WRENCH SET**

- 3/8" thick 6061-T6 billet aluminum
- Laser etched with fitting sizes
- Complete set from sizes -4 through -12



BEP41200 AN Wrench Set

**ADJUSTABLE AN ALUMINUM WRENCHES**

- Prevent scratching of aluminum anodized hose ends and fittings during installation and removal
- Billet aluminum, blue anodized



- BEP41080 -3 AN to -8 AN Wrench
- BEP41081 -3 AN to -20 AN Wrench

**PUSH-LOC FULL SWIVEL HOSE ENDS**

- Constructed from lightweight 6061 alloy aluminum
- Avoid twisting or kinking your lines during installation
- Lightweight and economical
- Assemble fast and trouble-free
- Use with ONLY Flex-Loc Push-On hose

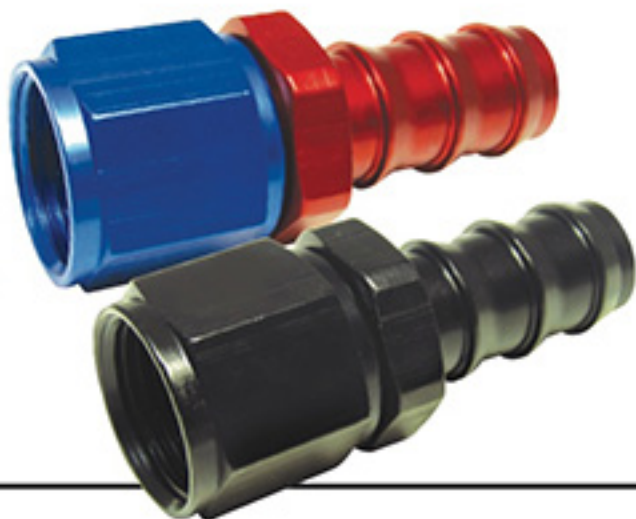

**STRAIGHT SWIVEL**

Red/Blue		Black	
BEP13401	-6 AN	BEP13451	-6 AN
BEP13402	-8 AN	BEP13452	-8 AN
BEP13403	-10 AN	BEP13453	-10 AN

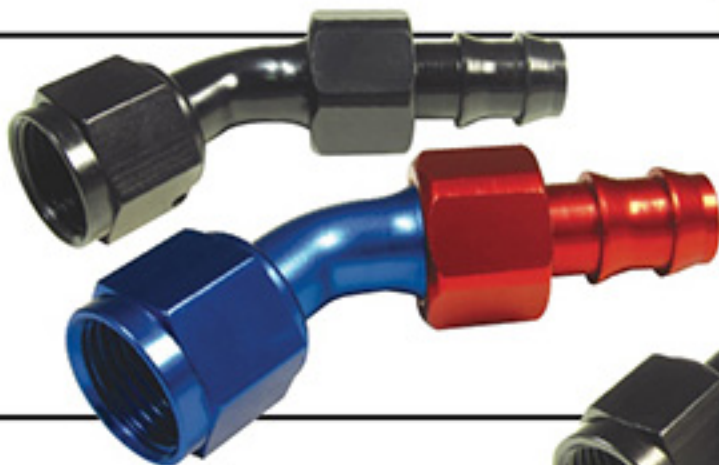

**45 DEGREE ELBOW**

Red/Blue		Black	
BEP13406	-6 AN	BEP13456	-6 AN
BEP13407	-8 AN	BEP13457	-8 AN
BEP13408	-10 AN	BEP13458	-10 AN

**90 DEGREE ELBOW**

Red/Blue		Black	
BEP13411	-6 AN	BEP13461	-6 AN
BEP13412	-8 AN	BEP13462	-8 AN
BEP13413	-10 AN	BEP13463	-10 AN

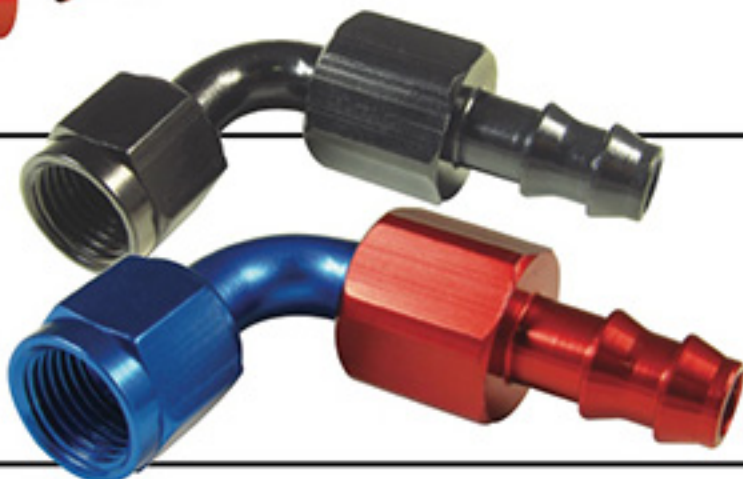

**EZ-ON HOSE PRESS**

- Makes installing push-on fittings easy!
- Will install -4 through -16 push-on hose onto fittings in seconds
- Constructed from investment cast steel
- Comes with a custom carrying case for safe storage and transportation



BEP41330 Ez-On Hose Press Tool

**FLEX-FUEL HOSE**

- Our 30R9 Flex-Fuel Hose is designed to handle today's various fuels and pump pressures
- Supports operating temperatures from -30° to 275°F
- Superior race fuel compatibility including: ethanol, extended fuels, E85, diesel and bio-diesel
- Constructed with black nylon and thin, stainless steel braid

10' Length, Black		20' Length, Black	
BEP13502	-6 AN	BEP13504	-6 AN
BEP13507	-8 AN	BEP13509	-8 AN
BEP13512	-10 AN	BEP13514	-10 AN



**HYDRA-FLEX™ ALUMINUM HOSE ENDS**

**STRAIGHT**

Red/Blue		Black	
BEP23401	-4 AN	BEP23402	-4 AN
BEP23601	-6 AN	BEP23602	-6 AN

**45 DEGREE**

Red/Blue		Black	
BEP23441	-4 AN	BEP23442	-4 AN
BEP23641	-6 AN	BEP23642	-6 AN

**90 DEGREE**

Red/Blue		Black	
BEP23491	-4 AN	BEP23492	-4 AN
BEP23691	-6 AN	BEP23692	-6 AN



**NEW  
FOR 2017**

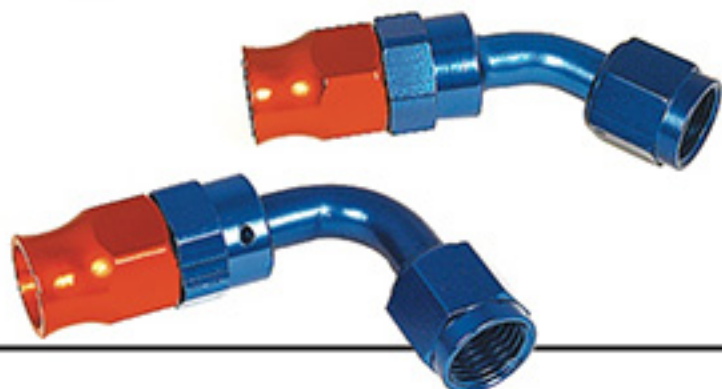

**HYDRA-FLEX™ HOSE ENDS**

- Used for brake lines, shocks and power steering hose
- Choose from straight, elbowed or banjo ends for the custom fit you need
- Machined from high quality steel
- Zinc plated for corrosion protection

**NEW  
FOR 2017**

Straight 1/8" Male Hose End  
BEP23100 1/8"



Brass Replacement Sleeves  
BEP23399 -3 AN, 5/pkg.  
BEP23499 -4 AN, 5/pkg.  
BEP23699 -6 AN, 5/pkg.



Straight Hose Ends  
BEP23300 -3 AN  
BEP23400 -4 AN  
BEP23600 -6 AN



Short Banjo Hose Ends  
3/8" 7/16"  
BEP23113 BEP23111 -3 AN



45° Hose Ends  
BEP23345 -3 AN  
BEP23445 -4 AN  
BEP23645 -6 AN



Banjo Hose Ends  
3/8" 7/16"  
BEP23110 BEP23112 -3 AN  
BEP23120 BEP23122 -4 AN



90° Hose Ends  
BEP23390 -3 AN  
BEP23490 -4 AN  
BEP23690 -6 AN



Inverted Flare Adapters  
BEP23250 -6 AN to 1/2"-20  
BEP23262 -6 AN to 5/8"-18  
BEP23268 -6 AN to 11/16"-18



**HYDRA-FLEX™ STAINLESS BRAIDED  
PTFE BRAKE LINE, GAS SHOCK AND  
POWER STEERING HOSE**

**NEW  
FOR 2017**

- Corrosion resistant PTFE inner tube reinforced with a 308 stainless steel outer braid
- Smooth-bore hose
- Protects critical fluids from heat, abrasion and line expansion
- Operating temps from -65°F to 450°F

3'	6'	10'	AN
BEP23303	BEP23306	BEP23310	-3AN
BEP23403	BEP23406	BEP23410	-4AN
BEP23603	BEP23606	BEP23610	-6AN



### STAINLESS STEEL BRAKE LINES

- Each line is constructed from smooth bore PTFE tube reinforced with a 308 stainless steel braided cover, allowing for a firmer and faster brake pedal response
- 3 AN lines conform to DOT specs
- Both -3 AN and -4 AN are available in both straight/straight or straight/90° hose end configurations



		Straight/Straight	
		BEP21209	-4 AN, 9"
		BEP21212	-4 AN, 12"
		BEP21215	-4 AN, 15"
		BEP21218	-4 AN, 18"
		BEP21221	-4 AN, 21"
		BEP21224	-4 AN, 24"
		BEP21230	-4 AN, 30"
		BEP21236	-4 AN, 36"
		BEP21242	-4 AN, 42"
		BEP21248	-4 AN, 48"
Straight/Straight			
BEP21009	-3 AN, 9"		
BEP21012	-3 AN, 12"		
BEP21015	-3 AN, 15"		
BEP21018	-3 AN, 18"		
BEP21020	-3 AN, 20"		
BEP21024	-3 AN, 24"		
BEP21030	-3 AN, 30"		
BEP21036	-3 AN, 36"		
Straight/90°		Straight/90°	
BEP21109	-3 AN, 9"	BEP21309	-4 AN, 9"
BEP21112	-3 AN, 12"	BEP21312	-4 AN, 12"
BEP21115	-3 AN, 15"	BEP21315	-4 AN, 15"
BEP21118	-3 AN, 18"	BEP21318	-4 AN, 18"
BEP21120	-3 AN, 20"	BEP21321	-4 AN, 21"
BEP21124	-3 AN, 24"	BEP21324	-4 AN, 24"
BEP21130	-3 AN, 30"	BEP21330	-4 AN, 30"
BEP21136	-3 AN, 36"	BEP21336	-4 AN, 36"
BEP21142	-3 AN, 42"	BEP21342	-4 AN, 42"

### BRAKE ADAPTER FITTINGS

- 3 AN to Pipe Adapter (sold each)
- BEP22000 1/8" to -3 AN Straight
- BEP22001 1/8" to -3 AN 45°
- BEP22002 1/8" to -3 AN 90°



- 3 AN Male Union (sold each)
- BEP22005 -3 AN Union **NEW!**



- AN to Inverted Flare Adapter
- BEP22020 -3 AN to 3/8"-24, 2/pkg. Male
- BEP22021 -3 AN to 7/16"-24, 2/pkg.
- BEP22022 -3 AN to 7/16"-20, 2/pkg.
- BEP22025 -4 AN to 3/8"-24, 2/pkg.
- BEP22030 -3 AN to 3/8"-24, 2/pkg. Female
- BEP22031 -3 AN to 7/16"-24, 2/pkg. Female **NEW!**
- BEP22032 -3 AN to 1/8" NPT, 2/pkg. Female **NEW!**
- BEP22033 -4 AN to 1/8" NPT, 2/pkg. Female **NEW!**



- 3 AN Banjo Adapter (sold each)
- BEP22010 10mm Straight to -3 AN
- BEP22011 10mm 35° to -3 AN
- BEP22012 10mm 90° to -3 AN
- BEP22013 7/16" Straight to -3 AN **NEW!**
- BEP22014 7/16" 35° to -3 AN **NEW!**
- BEP22015 7/16" 90° to -3 AN **NEW!**



- AN Flare Short Banjo Adapter
- BEP22040 -3 AN to 10mm
- BEP22041 -4 AN to 10mm
- BEP22042 -3 AN to 7/16" **NEW!**
- BEP22043 -4 AN to 7/16" **NEW!**



- Banjo Bolt
- BEP22070 10mm x 1.25
- BEP22071 10mm x 1.00
- BEP22072 10mm x 1.50



- 3 AN Flare Tee
- BEP22050 -3 AN Flare Tee



- Aluminum Crush Washer
- BEP22060 10mm, 10/pkg.
- BEP22061 7/16", 10/pkg.



### ADJUSTABLE PROPORTIONING VALVE

- Adjustable braking percentages
- Billet anodized black aluminum
- Easy finger-grip knob
- 1/8" female pipe ports
- Includes inverted flare adapters

BEP20000 Adjustable Proportioning Valve



### RESIDUAL VALVES

- Retain minimal fluid pressure by preventing drain back in the brake lines in applications where the master cylinder is located below the calipers
- 2-lb. residual brake pressure valve is used for disc brakes while the 10-lb. valve is used for drum brakes



BEP20010 2 lbs., Blue  
BEP20012 10 lbs., Red

**RACE TESTED AND PROVEN!**  
**BIG END™**  
PERFORMANCE PRODUCTS

### PROPORTIONING VALVES

- Perfect for conversions from drum to disc brakes

BEP20005 Disc/Disc, Brass  
BEP20007 Disc/Drum, Brass



**FLEX-LOC PUSH-ON HOSE, BLUE**

- Features a Class-A high oil resistant nitrile inner tube with a reinforcing 2-spiral aramid fiber and a nitrile/PVC cover resistant to oil and petroleum-based products
- Operates at 250 PSI and a temp. range of -30°F to 160°F
- Not recommended for use with unleaded gasoline, brake fluids or power steering fluids

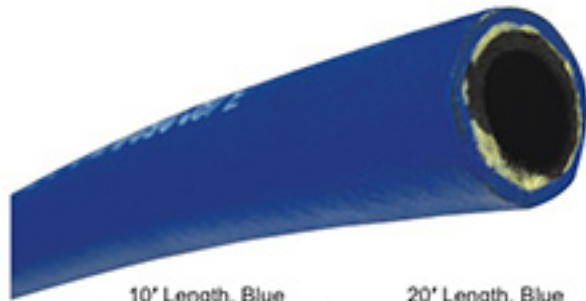

10' Length, Blue		20' Length, Blue	
BEP13105	-6 AN	BEP13130	-6 AN
BEP13110	-8 AN	BEP13135	-8 AN
BEP13115	-10 AN	BEP13140	-10 AN

**FLEX-LOC PUSH-ON HOSE, BLACK**



10' Length, Black		20' Length, Black	
BEP13155	-6 AN	BEP13180	-6 AN
BEP13160	-8 AN	BEP13185	-8 AN
BEP13165	-10 AN	BEP13190	-10 AN



**STAINLESS STEEL BRAIDED HOSE**

- Constructed of a durable CPE synthetic rubber tube bonded with a woven nylon braid and secured by a 308 stainless outer braid
- Resists extreme heat, abrasion and corrosion
- Compatible with alcohol and petroleum based fuels, motor oil and coolant
- Operating temps from -40°F to 350°F

10'	20'	AN	
BEP13410	BEP13420	-4AN	<b>NEW!</b>
BEP13610	BEP13620	-6AN	
BEP13810	BEP13820	-8AN	
BEP13010	BEP13020	-10AN	
BEP13210	BEP13220	-12AN	
BEP13310	N/A	-16AN	

**BLACK NYLON LIGHTWEIGHT BRAIDED HOSE**

- Made to the same high quality standards as our stainless steel hose using an outer braid of lightweight, oil resistant, quality black nylon fiber with inner liner
- Rated to a maximum pressure of 350 PSI on all sizes, and operating temp range of up to 275°F, making this the perfect choice for almost any customer
- Can be used with fuel, oil and antifreeze

10'	20'	AN	
BEP13422	BEP13421	-4 AN	<b>NEW!</b>
BEP13622	BEP13621	-6 AN	
BEP13822	BEP13821	-8 AN	
BEP13022	BEP13021	-10 AN	
BEP13222	BEP13221	-12 AN	





### DUAL INLET CARBURETOR LINE KITS

- Comes pre-assembled! Just tighten and install
- 1/8" NPT port for gauge provision
- Inlet gaskets included

Blue/Red Finish w/ Stainless Steel Hose

- BEP12112 -6 AN Kit Holley Ultra HP
- BEP12113 -6 AN Kit Demon w/ 9/16"-24 Bowl Fittings
- BEP12114 -8 AN Kit Holley Dominator 4500
- BEP12115 -8 AN Kit Holley 4150 Series
- BEP12116 -6 AN Kit Holley 4160, 8-21/32" Centers
- BEP12117 -6 AN Kit Holley 4150 Series
- BEP12118 -8 AN Inlet Kit Demon w/ 9/16"-24 Bowl Fittings
- BEP12119 -8 AN Kit Holley Ultra HP



Black Fittings w/ Black Hose

- BEP14102 -6 AN Kit Holley Ultra HP
- BEP14104 -8 AN Kit Holley Dominator 4500
- BEP14105 -8 AN Kit Holley 4150 Series
- BEP14107 -6 AN Kit Holley 4150 Series
- BEP14109 -8 AN Kit Holley Ultra HP

NOT BE SHOWN  
WITH MOUNTING PLATES  
CARBURETOR  
IS NOT INCLUDED



Black Finish w/ Stainless Steel Hose

- BEP14112 -6 AN Kit Holley Ultra HP
- BEP14113 -6 AN Kit Demon w/ 9/16"-24 Bowl Fittings
- BEP14114 -8 AN Kit Holley Dominator 4500
- BEP14115 -8 AN Kit Holley 4150 Series
- BEP14116 -6 AN Kit Holley 4160, 8-21/32" Centers
- BEP14117 -6 AN Kit Holley 4150 Series
- BEP14118 -8 AN Kit Demon w/ 9/16"-24 Bowl Fittings
- BEP14119 -8 AN Kit Holley Ultra HP



### PORT PLUGS AND O-RING

- Used to plug open ports
- Sold each

Blue	Black	
BEP12614	BEP14614	-6 AN
BEP12814	BEP14814	-8 AN
BEP12014	BEP14014	-10 AN
BEP12214	BEP14214	-12 AN

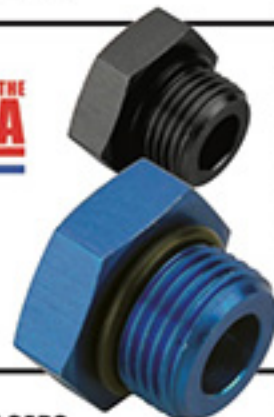

### STRAIGHT ADAPTER FITTINGS

- 3/7" AN flare fits standard AN ends, sold each

Blue	Black	
BEP12676	BEP14676	1/4" NPT to -6 AN
BEP12686	BEP14686	3/8" NPT to -6 AN
BEP12696	BEP14696	1/2" NPT to -6 AN
BEP12886	BEP14886	3/8" NPT to -8 AN
BEP12896	BEP14896	1/2" NPT to -8 AN
BEP12016	BEP14016	3/8" NPT to -10 AN
BEP12086	BEP14086	1/2" NPT to -10 AN
BEP12216	BEP14216	1/2" NPT to -12 AN
BEP12296	BEP14296	3/4" NPT to -12 AN
BEP12616	BEP14616	1/8" NPT to -6 AN
BEP12816	BEP14816	1/4" NPT to -8 AN



### AN FLARE CAPS

Blue	Black	
BEP12629	BEP14629	-6 AN
BEP12829	BEP14829	-8 AN
BEP12029	BEP14029	-10 AN
BEP12229	BEP14229	-12 AN





### HARD TUBE ADAPTERS

Blue	Black	
BEP12310	BEP14310	3/8" Tube to -6 AN Female
BEP12315	BEP14315	3/8" Tube to -6 AN Male
BEP12320	BEP14320	1/2" Tube to -8 AN Female
BEP12325	BEP14325	1/2" Tube to -8 AN Male

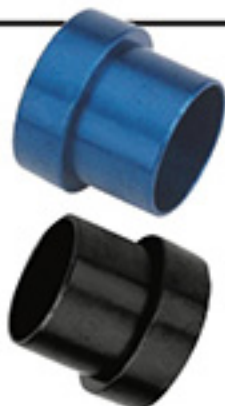

### TUBE SLEEVES



Blue		
BEP12619	-6 AN Sleeve, Pair	
BEP12819	-8 AN Sleeve, Pair	
BEP12019	-10 AN Sleeve, Each	
Black		
BEP14619	-6 AN Sleeve, Pair	
BEP14819	-8 AN Sleeve, Pair	
BEP14019	-10 AN Sleeve, Each	

### TUBE NUTS

Blue		
BEP12618	-6 AN Tube Nut, 2/pkg.	
BEP12818	-8 AN Tube Nut, 2/pkg.	
BEP12018	-10 AN Tube Nut, Each	
Black		
BEP14618	-6 AN Tube Nut, 2/pkg.	
BEP14818	-8 AN Tube Nut, 2/pkg.	
BEP14018	-10 AN Tube Nut, Each	



### STRAIGHT FEMALE AN SWIVEL COUPLER

Blue	Black	
BEP12306	BEP14306	-6 AN Female
BEP12308	BEP14308	-8 AN Female
BEP12300	BEP14300	-10 AN Female
BEP12302	BEP14302	-12 AN Female



### MALE FLARE UNION



Blue	Black	
BEP12615	BEP14615	-6 AN
BEP12815	BEP14815	-8 AN
BEP12015	BEP14015	-10 AN
BEP12215	BEP14215	-12 AN

### ALLEN SOCKET PIPE PLUGS

Blue	Black	
BEP12518	BEP14518	1/8" NPT, 2/pkg.
BEP12514	BEP14514	1/4" NPT, 2/pkg.
BEP12538	BEP14538	3/8" NPT, 2/pkg.
BEP12512	BEP14512	1/2" NPT, 1/pkg.
BEP12534	BEP14534	3/4" NPT, 1/pkg.



### FEMALE TO MALE EXPANDERS AND REDUCERS

- These expanders and reducers allow you to go up or down one AN size easily, especially when trying to go a size larger or smaller on a pre-welded fitting such as with a fuel cell

Blue	Black	
Expanders		
BEP12330	BEP14330	-4 AN to -6 AN
BEP12331	BEP14331	-6 AN to -8 AN
BEP12332	BEP14332	-8 AN to -10 AN
BEP12333	BEP14333	-10 AN to -12 AN
Reducers		
BEP12340	BEP14340	-6 AN Female to -4 AN Male
BEP12341	BEP14341	-8 AN Female to -6 AN Male
BEP12342	BEP14342	-10 AN Female to -8 AN Male
BEP12343	BEP14343	-12 AN Female to -10 AN Male



### PTFE SEALING WASHERS

- Replacement washers for Big End fuel cell bulkhead fittings available from -6 through -12 AN

BEP14395	PTFE Washer -6 AN
BEP14396	PTFE Washer -8 AN
BEP14397	PTFE Washer -10 AN
BEP14398	PTFE Washer -12 AN



### FUEL CELL BULKHEADS

- Made from 6061-T6 aluminum, these fuel cell bulkheads include a nut and PTFE washers  
- Black anodized finish

BEP14390	Fuel Cell Bulkhead -6 AN
BEP14391	Fuel Cell Bulkhead -8 AN
BEP14392	Fuel Cell Bulkhead -10 AN
BEP14393	Fuel Cell Bulkhead -12 AN



### GAUGE ADAPTERS

- 1/8" NPT gauge port adapter fittings. AN to AN or NPT to AN

Blue	Black	
BEP12441	N/A	-4 AN Female to -4 AN Male
BEP12661	BEP14661	-6 AN Female to -6 AN Male
BEP12688	BEP14688	3/8" NPT Male to -6 AN Male
BEP12881	BEP14881	-8 AN Female to -8 AN Male
BEP12888	BEP14888	3/8" NPT Male to -8 AN Male



### AN RADIUS PORT ADAPTERS WITH O-RING

- For maximum flow. Sold each



Blue	Black	
BEP12766	BEP14766	-6 AN Port to -6 AN
BEP12768	BEP14768	-6 AN Port to -8 AN
BEP12786	BEP14786	-8 AN Port to -6 AN
BEP12788	BEP14788	-8 AN Port to -8 AN
BEP12781	BEP14781	-8 AN Port to -10 AN
BEP12706	BEP14706	-10 AN Port to -6 AN
BEP12708	BEP14708	-10 AN Port to -8 AN
BEP12701	BEP14701	-10 AN Port to -10 AN
BEP12702	BEP14702	-10 AN Port to -12 AN
BEP12721	BEP14721	-12 AN Port to -10 AN
BEP12722	BEP14722	-12 AN Port to -12 AN



### 90 DEGREE

Blue	Black	
BEP12622	BEP14622	1/8" NPT to -6 AN
BEP12682	BEP14682	1/4" NPT to -6 AN
BEP12692	BEP14692	3/8" NPT to -6 AN
BEP12822	BEP14822	1/4" NPT to -8 AN
BEP12882	BEP14882	3/8" NPT to -8 AN
BEP12892	BEP14892	1/2" NPT to -8 AN
BEP12022	BEP14022	1/2" NPT to -10 AN
BEP12092	BEP14092	3/4" NPT to -10 AN
BEP12222	BEP14222	1/2" NPT to -12 AN
BEP12292	BEP14292	3/4" NPT to -12 AN

### FUEL PUMP FITTINGS

- These inverted flare fittings are the perfect way to finish off your fuel system with a leak free connection and a professional look



Blue	
BEP12130	Adapter -6 AN x 1/2"-20
BEP12131	Adapter -6 AN x 5/8"-18
Black	
BEP14130	Adapter -6 AN x 1/2"-20
BEP14131	Adapter -6 AN x 5/8"-18



### 45 DEGREE

Blue	Black	
BEP12623	BEP14623	1/4" NPT to -6 AN
BEP12823	BEP14823	3/8" NPT to -8 AN
BEP12023	BEP14023	1/2" NPT to -10 AN
BEP12223	BEP14223	3/4" NPT to -12 AN

### FUEL RAIL FITTINGS

- Fuel injection fittings allow the use of stock fuel rails with AN style lines



Blue	
BEP12140	-6 AN to 14mm x 1.5 O-Ring
BEP12141	-6 AN to 16mm x 1.5 O-Ring
Black	
BEP14140	-6 AN to 14mm x 1.5 O-Ring
BEP14141	-6 AN to 16mm x 1.5 O-Ring



### CARBURETOR INLET ADAPTERS

- Blue or black anodized



Blue	Black	
BEP12167	BEP14167	-6 AN to Edelbrock and Carter AFB, each
BEP12168	BEP14168	-6 AN to 7/8"-20 Holley Dual Inlet 2/pkg.
BEP12169	BEP14169	-6 AN to 9/16"-24 BG Demon and Holley Single Inlet, 2/pkg.
BEP12187	BEP14187	-8 AN to 7/8"-20 Holley Dual Inlet Short Style, 2/pkg.
BEP12188	BEP14188	-8 AN to 7/8"-20 Holley Dual Inlet Long style, 2/pkg.
BEP12189	BEP14189	-8 AN to 9/16"-24 BG Demon and Holley Single Inlet, 2/pkg.

### CARB EXTENSION FITTINGS

- Long style female carb inlet adapters  
- Sold in pairs



Blue	
BEP12120	Holley 7/8"-20 to -8 AN Female
BEP12121	Holley 7/8"-20 to -6 AN Female
Black	
BEP14120	Holley 7/8"-20 to -8 AN Female
BEP14121	Holley 7/8"-20 to -6 AN Female



**AN Y-FITTINGS**

- CNC-machined, 6061-T6 aluminum

Blue, Male Y-Fitting

- BEP12350 -6 AN in/Dual -6 AN out
- BEP12351 -8 AN in/Dual -6 AN out
- BEP12352 -8 AN in/Dual -8 AN out
- BEP12353 -10 AN in/Dual -8 AN out
- BEP12354 -10 AN in/Dual -10 AN out
- BEP12356 -12 AN in/Dual -12 AN out

Black, Male Y-Fitting

- BEP14350 -6 AN in/Dual -6 AN out
- BEP14351 -8 AN in/Dual -6 AN out
- BEP14352 -8 AN in/Dual -8 AN out
- BEP14353 -10 AN in/Dual -8 AN out
- BEP14354 -10 AN in/Dual -10 AN out
- BEP14356 -12 AN in/Dual -12 AN out

Black, Female Y-Block

- BEP14360 -10 AN in/Dual -8 AN out



**INSULATED CLAMPS**

- Aluminum clamps insulated with Adel rubber material  
- Makes mounting fuel lines and wiring easy

- BEP65000 1/4" I.D., 20/pkg.
- BEP65001 3/8" I.D., 20/pkg.
- BEP65002 1/2" I.D., 15/pkg.
- BEP65003 5/8" I.D., 12/pkg.
- BEP65004 3/4" I.D., 10/pkg.
- BEP65005 1" I.D., 6/pkg.



**ALUMINUM FUEL LINE**

- Provides more fuel volume to the carburetor  
- Legal in all racing classes  
- 25' long rolls

- BEP10000 3/8" Line Tubing
- BEP10002 5/8" Line Tubing

**HIGH QUALITY PRODUCTS  
PRICED RIGHT!**



**ONE-WAY CHECK VALVES**

- Compatible with all fuels, oils and coolants
- Functions in demanding environments
- High grade lightweight materials
- Less restrictive hinged flapper style design
- Low opening pressure: 2 PSI
- Operating pressure range: 2-1500 PSI
- Operating temperature range: -30°F to 400°F



- |                 |                 |  |
|-----------------|-----------------|--|
| Blue            | Black           |  |
| BEP12962 -6 AN  | BEP14962 -6 AN  |  |
| BEP12982 -8 AN  | BEP14982 -8 AN  |  |
| BEP12902 -10 AN | BEP14902 -10 AN |  |
| BEP12922 -12 AN | BEP14922 -12 AN |  |



**ALUMINUM WELDING BUNGS**

- Made from 6061 aluminum, bungs are non-anodized and lipped to prevent warpage  
- Available in male AN and female NPT

- |                           |                               |
|---------------------------|-------------------------------|
| BEP12560 Male Bung -6 AN  | BEP12550 Female NPT Bung 1/8" |
| BEP12561 Male Bung -8 AN  | BEP12551 Female NPT Bung 1/4" |
| BEP12562 Male Bung -10 AN | BEP12552 Female NPT Bung 3/8" |
| BEP12563 Male Bung -12 AN | BEP12553 Female NPT Bung 1/2" |
| BEP12564 Male Bung -16 AN | BEP12554 Female NPT Bung 3/4" |

**COMPLETE AN HOSE PRESSURE TEST KIT**

- Allows you to test all of your AN hose assemblies before you put them on your car
- Includes an air valve and matching plug for each size from -3 AN through -16 AN and comes in a convenient clear plastic case to store it all in
- Can be used with either compressed air or nitrogen

- BEP14950 Pressure Test Kit, -3 AN through -16 AN



### BILLET IN-LINE RACE FUEL FILTERS

- Lightweight billet 6061-T6 aircraft aluminum
- 150 GPH at 9 PSI for fuel injection or carbureted applications
- 10 micron cellulose element or 100 micron S/S pleated element
- Blue or black anodized finish with laser etched logo
- Size: 1-3/4" x 6-1/2"



Blue	Black	
BEP12110	BEP14110	-10 AN 10 Micron Cellulose
BEP12100	BEP14100	-10 AN 100 Micron Stainless
BEP12810	BEP14810	-8 AN 10 Micron Cellulose
BEP12811	BEP14811	-8 AN 100 Micron Stainless

BEP12912	Replacement O-Ring
BEP12910	Replacement Cellulose 10 Micron
BEP12911	Replacement Stainless 100 Micron



### BILLET IN-LINE STREET FILTERS



- Made from lightweight billet 6061-T6 aircraft aluminum
- Designed for carbureted systems, filters flow 95 GPH at 7 PSI and have a reusable 40-micron element
- Precision CNC-machined 2-piece construction
- 6 AN is 1-3/4" x 3-3/4"
- 8 AN is 1-1/4" x 4"

BEP12960	-6 AN Blue
BEP12961	-6 AN Machined, Polished
BEP12980	-8 AN Blue
BEP12981	-8 AN Machined, Polished
BEP14960	-6 AN Black
BEP14980	-8 AN Black
BEP12900	Replacement O-Ring
BEP12901	Replacement Filter Screen

### MECHANICAL STREET FUEL PUMPS

- 80 GPH
- Shut off pressure: 7-1/2 PSI
- 1/4" NPT inlet/outlet ports
- Shiny finish

BEP10100	SBC 80 GPH
BEP10110	BBC 80 GPH
BEP10120	SBF Windsor 80 GPH



### MECHANICAL STREET/STRIP FUEL PUMPS

- 110 GPH (free-flow)
- Shut off pressure: 6-1/2 to 8 PSI
- Inlet and outlet are 3/8" NPT
- Shiny finish

BEP10105	SBC 110 GPH
BEP10115	BBC 110 GPH
BEP10125	SBF Windsor 110 GPH

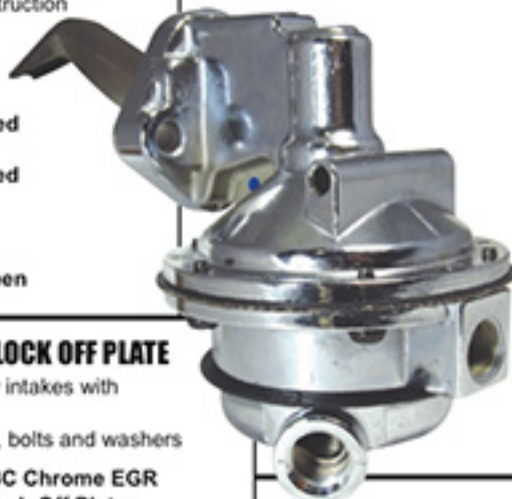

### CHROME EGR BLOCK OFF PLATE

- For all SB Chevy intakes with EGR provision
- Mounting gasket, bolts and washers

BEP11085	SBC Chrome EGR Block-Off Plate
----------	--------------------------------

### CHROME FUEL BLOCK OFF PLATES

- Chrome plated steel, includes mounting gasket

BEP10050	SB Chevy
BEP10055	BB Chevy, Ford (exc. 351C-400), Mopar, Pontiac, Olds



### FUEL PUMP MOUNTING PLATE

- For 265-400 SB Chevy
- Chrome plated steel
- Gasket included

BEP10051	Mounting Plate
----------	----------------



### BILLET FUEL PUMP BLOCK OFF PLATES

- Made of CNC-machined 6061-T6 billet aluminum
- Anodized finish

SB Chevrolet	
BEP10060	Aluminum
BEP10061	Blue
BEP10062	Red
BEP10063	Black

BB Chevrolet, Ford and Mopar	
BEP10065	Aluminum
BEP10066	Blue
BEP10067	Red
BEP10068	Black
(All Ford except 351C, M400)	



### DON'T FORGET THE GASKETS!

BEP49605	F.P. Gasket, 10/pkg.
BEP49610	F.P. Mounting Plate Gasket, 10/pkg.

**LIGHTWEIGHT FUEL PUMP PUSHROD**

- Designed for high RPM cast iron core camshafts
- Lightweight design prevents float over 6,000 RPM
- Machined from 4130 chrome-moly tubing



BEP10101 Fuel Pump Pushrod



**HIGH FLOW CHROME CANISTER FILTERS**

- 10 micron paper element flows up to 90 GPH @ 9 PSI
- 3/8" NPT inlet and outlet ports
- Not for use with fuel injection

BEP11075 Competition Filter  
 BEP11076 Element for 11075  
 BEP11077 Street / Strip Filter  
 BEP11078 Element for 11077



**ELECTRIC FUEL PUMPS**

**STREET PUMP**

- 95 GPH free flow
- Factory set at 7 PSI
- 3/8" NPT inlet and outlet ports

BEP10150 Street Pump

**STREET/STRIP PUMP**

- 110 GPH free flow capable of 14 PSI
- Factory set at 7 PSI
- 3/8" NPT inlet and outlet ports
- Includes regulator

BEP10155 Street/Strip Pump w/ Regulator

**RACING PUMP**

- 130 GPH free flow
- Max pressure of 14 PSI
- Compatible with alcohol and methanol
- 3/8" NPT inlet and outlet ports

BEP10160 Racing Pump



**FUEL PRESSURE REGULATOR**

- Adjustable from 4-1/2 to 9 PSI
- 3/8" NPT inlet and outlet ports
- Includes mounting bracket and hardware

BEP10165 Fuel Pressure Regulator



**INLINE EFI FUEL PUMP - 45 GPH**

- Ideal for late model engine swaps and for use as a booster pump in a nitrous oxide application
- 5/16" barbed hose ends
- Includes 2 cushioned mounting clamps
- This pump is rated to 500 HP naturally aspirated and flows 45 GPH @ 40 PSI

BEP10180 EFI Inline Pump, 45 GPH

**BILLET RETURN STYLE FUEL PRESSURE REGULATORS**

- Designed for use with electric fuel pumps
- 2-pc. anodized billet aluminum
- Compatible with gasoline and ethanol blends including E85
- -8 O-ring side inlet and bottom return
- (3) 3/8" NPT side outlet ports
- (1) 1/8" NPT gauge port

BEP10177 4-Port, 1.5-25 PSI  
 BEP10178 4-Port, 30-100 PSI  
 BEP10179 3-Port, 4.5-14 PSI (No Return)



**INLINE EFI FUEL PUMP - 70 GPH**

- High performance, high flow rate pump that can support up to 900 HP on a carbureted N.A. engine to 500 HP on a forced induction EFI engine
- Features a -8 AN female inlet and -6 AN female outlet
- Comes complete with 2 T-bar mounting clamps
- This pump flows 110 GPH free flow with a rating of 70 GPH @ 45 PSI

BEP10185 EFI Inline Pump, 70 GPH

**ELECTRIC FUEL PUMPS**

- Works well as a fuel transfer pump and makes a great standalone or booster pump
- Compatible with all fuels and additives
- Solid-state worry free electronics
- Eliminates vapor lock and flooding

BEP10130 Gas, 4-7 PSI  
 BEP10135 Gas, 2-3.5 PSI  
 BEP10140 Diesel, 4-7 PSI



### BILLET ALUMINUM THROTTLE CABLE BRACKETS WITH RETURN SPRINGS

- CNC-machined from aircraft quality 6061-T6 billet aluminum
- Furnished with a specially designed adjustable carburetor throttle cable end that is specifically machined to fit GM Snap, Ford, Lokar or Morse throttle cables to fine tune the perfect cable tension
- Complete with stainless hardware

Holley 4150/4160 Series		Holley 4500 Dominator Series	
BEP16000	GM Snap Cables	BEP16010	GM Snap Cables
BEP16001	Lokar Cables	BEP16011	Lokar Cables
BEP16002	Morse Cables	BEP16012	Morse Cables
BEP16003	Ford Cables	BEP16013	Ford Cables

#### Black Anodized Brackets

BEP16020	Fits Edelbrock 4150 Carb, Accepts GM Cable
BEP16021	Fits Edelbrock 4150 Carb, Accepts Lokar Cable
BEP16030	Fits 4500 Carb, Accepts GM Cable
BEP16031	Fits 4500 Carb, Accepts Lokar Cable



MADE IN THE USA

### BILLET ALUMINUM THROTTLE RETURN BRACKETS

- CNC-machined from aircraft quality 6061-T6 billet aluminum
- Each bracket is equipped with dual stainless steel return springs and a fully adjustable billet aluminum mount
- Securely mounts to the carburetor base studs
- Hard coat clear anodized finish protects from corrosion
- Comes complete with stainless steel hardware



BEP16004	Holley 4150/4160
BEP16014	Holley 4500 Dominator

MADE IN THE USA

### DOMINATOR SHEAR PLATES

- Feature a 7" tapered bore designed to help make the Dominator perform at its peak
- CNC-machined from 6061-T6 billet aluminum
- Hard clear anodized finish protects from corrosion



BEP10950	2" Bore
BEP10951	2-1/4" Bore
BEP10955	1-3/4" Bore

### BILLET ALUMINUM FUEL PRESSURE REGULATOR MOUNTING BRACKETS

- CNC-machined from 6061-T6 billet aluminum
- Directly mounts to carburetor base studs. Bracket bolt patterns are drilled to accept Holley, Aeromotive and Magnafuel 2-port regulators
- Includes stainless steel hardware
- Hard coat clear anodized finish protects from corrosion



BEP16300

MADE IN THE USA

\*REGULATOR NOT INCLUDED

Holley 4150/4160 Series Carburetors	
BEP16300	Aeromotive Regulators
BEP16301	Holley Regulators/BEP10165
BEP16302	Magnafuel, Small 2-Port

Holley 4500 Dominator Series	
BEP16310	Aeromotive Regulators
BEP16311	Holley Regulators/BEP10165
BEP16312	Magnafuel, Small 2-Port

### BILLET CARBURETED FUEL PRESSURE REGULATOR

- Carbureted regulator handles pressure range from 3-12 PSI
- -6 AN O-ring boss inlet and outlet port sizes and has an 1/8" NPT gauge port on the front of the regulator
- Includes mounting bracket
- Black anodized
- Gas or alcohol compatible

BEP10175	Carbureted Regulator
----------	----------------------



### BILLET EFI BYPASS FUEL PRESSURE REGULATOR

- Handles pressure ranges from 30-65 PSI
- -6 AN O-ring ports for inlet, outlet and return with 1/8" NPT gauge port on front
- Boost referenced to supply increased fuel for superchargers and turbos at 1:1 ratio
- Includes mounting bracket
- Gas or alcohol compatible

BEP10176	EFI Regulator
----------	---------------



### CARBURETOR ADAPTER KIT

- Adapts Holley or AFB 4bbl carb to Quadrajets manifold or flips over to adapt Quadrajets carb to Holley or AFB 4bbl
- Die-cast aluminum 1" adapter
- All gaskets and hardware included

BEP11000 Carburetor Adapter Kit



MADE IN THE USA

### CARBURETOR BASE GASKETS

- Made of durable heat-resistant nitrile rubber compound
- 1/16" thick; die-cut for an exact base mounting fit
- 10 per package



MADE IN THE USA

### BILLET CARB SPACERS

- CNC-machined from billet aluminum, making them ultra-light
- Precision bored to match carburetor base plates for a precise fit



Open Center		4-Hole	
BEP10500	.500" 4150-Style	BEP10510	.500" 4150 Style
BEP10501	1.00" 4150 Style	BEP10511	1.00" 4150 Style
BEP10506	1.00" 4500 Style	BEP10515	.500" 4500-Style

- BEP10800 Holley 4150, 4160 4bbl, Carter AFB, Open Hole, 10/pkg.
- BEP10802 Holley 4150, 4160 4bbl, Carter AFB, 4-Hole, 10/pkg.
- BEP10805 Holley 4150, 4160, Carter AFB, Edelbrock, 4bbl non-stick pair pack Quadrajets, Open Hole, 10/pkg.
- BEP10808 Holley 4500 Dominator, 4-Hole, 10/pkg.
- BEP10816 Holley 4500 Dominator, 4-Hole, 10/pkg.
- BEP10817 Holley 4500 Dominator, Open Hole, 10/pkg.
- BEP10823 Holley 2bbl 2300 Ported 2-Hole 10/pkg.

### HI-TECH SPACERS

- Made of a space-age phenolic material that thermally insulates between the intake manifold and carburetor
- CNC-machined to exact tolerances

#### 4150 Series Flange

- BEP10850 4-Hole, 1/2" Tall Carb Spacer
- BEP10852 4-Hole, 1" Tall Carb Spacer
- BEP10860 Open, 1/2" Tall Carb Spacer
- BEP10862 Open, 1" Tall Carb Spacer
- BEP10864 Open, 2" Tall Carb Spacer

#### 4500 Series Flange

- BEP10851 4-Hole, 1/2" Tall Carb Spacer
- BEP10853 4-Hole, 1" Tall Carb Spacer
- BEP10861 Open, 1/2" Tall Carb Spacer
- BEP10863 Open, 1" Tall Carb Spacer
- BEP10865 Open, 2" Tall Carb Spacer

MADE IN THE USA



MADE IN THE USA



### BIG FLOW 3-D CARB SPACERS

- Adds 10 to 50 HP and consistent E.T.s.
- 3-D, 4-hole contoured design features a flow enhancer cavity that increases flow under the carb, and aids in consistency when used under throttle stops
- Isolates heat from intake to carb, and withstands temps up to 400°F

4150 Series Carbs  
BEP10875 1" Spacer  
BEP10877 2" Spacer

4500 Series Carbs  
BEP10876 1" Spacer  
BEP10878 2" Spacer



### THROTTLE CABLE BRACKET AND RETURN SPRING KIT

- S/S throttle cable bracket for a clean hot rod-performance look
- Mounts to carburetor stud
- Dual stainless steel return springs
- For use with Big End S/S throttle cable assemblies



BEP11041 Throttle Cable Bracket Kit

### FUEL BOWL GASKETS

- Feature a fluorocarbon release blue non-stick coating
- Fits Holley 2300, 4150 and 4500 model carburetors

BEP10200 Fuel Bowl Gaskets, 2/pkg.  
BEP10210 Fuel Bowl Gaskets, 10/pkg.  
BEP10201 Fuel Bowl Gaskets 4500 Series, 2/pkg.  
BEP10211 Fuel Bowl Gaskets 4500 Series, 10/pkg.

### METERING BLOCK GASKETS

- Feature a fluorocarbon release blue non-stick coating
- Fits Holley 4150, 4160, 2300, 2 and 3-circuit 4500 carbs

BEP10205 Metering Block Gaskets, 2/pkg.  
BEP10215 Metering Block Gaskets, 10/pkg.  
BEP10206 Metering Bk Gaskets 4500 3 Circuit, 2/pkg.  
BEP10216 Metering Bk Gaskets 4500 3 Circuit, 10/pkg.

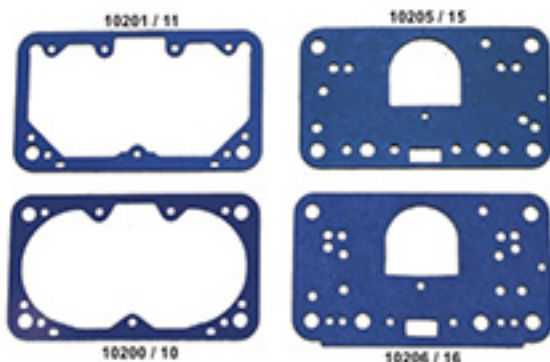

MADE IN THE USA

### ACCELERATOR PUMP DIAPHRAGMS

- Available in both rubber and alcohol safe GFLT material
- Both 30cc and 50cc available
- Sold individually

BEP10220 30cc Rubber Pump Diaphragm  
BEP10223 30cc GFLT Pump Diaphragm  
BEP10225 50cc Rubber Pump Diaphragm  
BEP10228 50cc GFLT Pump Diaphragm



### CHROME DUAL RETURN SPRING KIT

- Universal plated steel mounting bracket and dual spring kit
- Provides instant throttle return

BEP11030 Universal Throttle Return Spring Kit

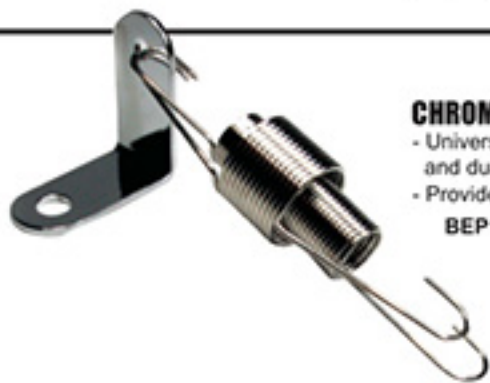

### FUEL BOWL INLET FITTINGS

- Fits all Holley center-hung fuel bowls
- Inverted flare 7/8"-20 x 5/8"-18 for 3/8" tube dual feed lines
- Steel plug with zinc plating with gasket

BEP10260 Fuel Bowl Fitting, ea.

MADE IN THE USA



### POWER VALVE PLUG

- Fits all Holley carburetors where fuel enrichment from the power valve is not desired in race applications
- Kit includes threaded plug and gasket

BEP10255 Power Valve Plug

MADE IN THE USA



### NYLON FLOAT BOWL WASHER KIT

- High compression washers are unaffected by fuel and alcohol
- Will not tear or deteriorate like standard fiber washers

BEP10230 Nylon Float Bowl Washers, 10/pkg.

MADE IN THE USA



### VACUUM SECONDARY DIAPHRAGM

- Made from high quality rubber
- Replacement for most vacuum secondary Holley carburetors

BEP10235 Vacuum Secondary Diaphragm

MADE IN THE USA



### VACUUM SECONDARY SPRING KIT

- Comes with 7 different springs ranging from super light to heavy

BEP10258 Vacuum Secondary Spring Kit



### CARB MOUNTED THROTTLE RETURN SPRING KIT

- Fits Holley 2300/4150/4160 carburetors
- Bracket is chrome plated steel
- Springs and mounting hardware included



BEP11035 Throttle Return Spring Kit

**WIDE OPEN THROTTLE MICRO SWITCH AND MOUNTING BRACKET**

- Lightweight billet aluminum and precision fit to your carb for precise activation of the microswitch
- Includes stainless steel mounting hardware for the microswitch as well as for mounting the bracket
- Available for 4150/4160 and 4500 series carburetors
- Black anodized finish



**MADE IN THE USA**

BEP16200 WOT and Bracket, Holley 4150/4160  
 BEP16210 WOT and Bracket, Holley 4500 Dominator

**BILLET NITROUS/FUEL BRACKETS WITH THROTTLE KIT**

- Features a billet nitrous/fuel bracket combined with a throttle cable mount and dual return springs. Plus an additional nitrous/fuel solenoid mounting bracket for an all-in-one installation
- CNC-machined from 6061-T6 billet aluminum
- Easily mounts to the carburetor studs on Holley 4150/4160 or a 4500 Dominator series carburetor
- Fully adjustable throttle and return spring brackets
- Includes S/S springs and S/S mounting hardware
- Hard clear anodized finish protects against corrosion



Holley 4150/4160 Series Carburetors  
 BEP16100 Billet Brackets w/ Throttle Kit, GM Snap Cable  
 BEP16101 Billet Brackets w/ Throttle Kit, Lokar Cable

Holley 4500 Dominator Series Carb  
 BEP16110 Billet Brackets w/ Throttle Kit, GM Snap Cable  
 BEP16111 Billet Brackets w/ Throttle Kit, Lokar Cable

**MADE IN THE USA**

**BILLET NITROUS/FUEL SOLENOID BRACKET KIT**

- CNC-machined from 6061-T6 billet aluminum
- Mounts any single nitrous/fuel solenoid using stainless steel hardware
- Easily mounts to the carburetor studs on Holley 4150/4160 or 4500 Dominator series carburetor
- Hard clear anodized finish protects from corrosion
- Sold as a pair

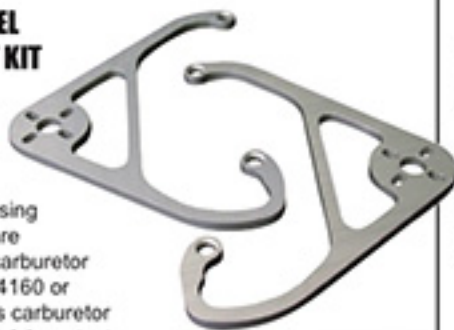

**MADE IN THE USA**

BEP16105 Nitrous/Fuel Solenoid Bracket Kit, Holley 4150/4160, pair  
 BEP16115 Nitrous/Fuel Solenoid Bracket Kit, Holley 4500 Dominator, pair

**S/S THROTTLE CABLE ASSEMBLY**

- PTFE inner liner and stainless braided outer covering
- Aluminum ends with threaded nut assembly on the cable bracket
- Aluminum clevis and swivel throttle stud
- Universal, trim-to-fit



BEP11046 24" (Fits Most Single Carburetors)  
 BEP11047 36" (Fits Most Tunnel Ram, Blower, and EFI Applications)

**MADE IN THE USA**

**NITROUS DISTRIBUTION BLOCKS**

- These distribution blocks are machined from 6061 billet aluminum and feature 1, 1/8" NPT inlet and 4, 1/8" NPT outlets

**MADE IN THE USA**



BEP35510 Dist. Block, Blue  
 BEP35515 Dist. Block, Red

**NITROUS COMBO WRENCH**

- Wrench includes all fitting sizes needed for nitrous systems on one handle.
- Machined out of one piece of billet aluminum and has the capability of tightening -3 AN, -4 AN, -6 AN and 1-1/4" bottle nuts
- Black anodized and laser etched for easy size identification



BEP41205 Nitrous Combo Wrench

**FILTERED NITROUS FITTINGS**

- These adapter fittings include a filter screen machined into them to keep any particles out of your nitrous system



BEP35500 1/8" -4 AN N<sub>2</sub>O Filter, Blue  
 BEP35501 1/8" -4 AN N<sub>2</sub>O Fuel Filter, Red  
 BEP35502 1/4" -4 AN N<sub>2</sub>O Filter, Blue  
 BEP35503 1/8" -6 AN N<sub>2</sub>O Filter, Blue  
 BEP35504 1/4" -6 AN N<sub>2</sub>O Filter, Blue  
 BEP35505 1/4" -6 AN N<sub>2</sub>O Fuel Filter, Red

**CLEAR FUEL BOWL SIGHT PLUGS**

- Make quick checks and adjustments
- Includes 2 clear plugs with viton O-rings

BEP10250 Clear Sight Plugs, 2/pkg.



**PLASTIC CARBURETOR COVER CAP**

- Molded plastic and resistant to gasoline
- Keep debris out of your carb in storage
- Includes wing bolt

BEP11080 Plastic Carb Cap Cover, 5-1/8" Necks



**CARBURETOR JET ASSORTMENT KIT**

- Standard 1/4"-32 jets
- Contains 2 ea. of 36 jets in sizes 64-99
- Plastic case with labeled compartments

BEP10270 Carb Jet Assortment Kit



**HIGH QUALITY PRODUCTS  
PRICED RIGHT!**  
**BIG END**  
PERFORMANCE PRODUCTS

**BILLET ALUMINUM KICK DOWN  
DETENT CABLE BRACKETS**

- Attaches to the bottom of our throttle brackets using stainless steel hardware
- Fully adjustable to fine tune the perfect cable tension
- CNC-machined from billet aluminum
- Hard coat clear anodized finish protects against corrosion

BEP16050 GM Snap Cable  
BEP16051 Lokar Cable  
BEP16055 GM Snap Cable, Black  
BEP16056 Lokar Cable, Black



**PERFORMANCE CARB REBUILD KITS**

- Includes precision die-cut gaskets, non-stick on Holley style kits; needle and seat assemblies; and accelerator pump diaphragms
- Many applications including Edelbrock and Holley carbs

BEP10240 4150 Double Pump Carbs  
BEP10242 4160 Vacuum Secondary Carbs  
BEP10245 2300 Series 2bbl Carbs  
BEP10247 Edelbrock/ AFB Style Carbs

**POWER VALVES**

- Available in many vacuum ranges
- Sold individually with a gasket

BEP10290 2.5"  
BEP10291 3.5"  
BEP10292 4.5"  
BEP10293 5.5"  
BEP10294 6.5"  
BEP10295 7.5"  
BEP10296 8.5"



**CARBURETOR STUD KIT**

- Bright zinc-plated threaded 5/16"-18 at one end and 5/16"-24 on the other end
- Package contains: 4 studs, 4 nuts, 4 washers



BEP65100 Standard, 1-3/8" Length  
BEP65105 Long, 2" Length  
BEP65110 Extra Long, 3" Length

**NEEDLE AND SEAT ASSEMBLIES**

- Viton needles stand up to all gasoline applications using center hung floats
- Sold individually

BEP10280 Viton .097  
BEP10281 Viton .110  
BEP10282 Viton .120  
BEP10285 Hardware Kit



**VACUUM CAP KIT**

- Colored vinyl vacuum line cap kit



BEP55013 Vacuum Cap Kit, 20-pc.

**ASSEMBLED NITROUS FEED LINES**

- Make plumbing your nitrous system a snap
- Each line is made from PTFE core stainless steel crimped on the ends with either blue (nitrous) or red (fuel) fittings
- Tested to ensure there are no leaks
- Choose from many lengths and sizes



Blue Lines	
BEP35000	-3 AN x 8.5"
BEP35001	-3 AN x 12"
BEP35002	-3 AN x 18"
BEP35003	-3 AN x 24"
BEP35010	-4 AN x 8.5"
BEP35011	-4 AN x 12"
BEP35012	-4 AN x 18"
BEP35013	-4 AN x 24"
BEP35014	-4 AN x 3'
BEP35015	-4 AN x 4'
BEP35016	-4 AN x 6'

Blue Lines	
BEP35019	-4 AN x 12'
BEP35020	-4 AN x 14'
BEP35021	-4 AN x 16'
BEP35023	-4 AN x 20'
BEP35050	-6 AN x 12"
BEP35051	-6 AN x 24"
BEP35052	-6 AN x 4'
BEP35053	-6 AN x 6'
BEP35055	-6 AN x 10'
BEP35057	-6 AN x 14'
BEP35058	-6 AN x 16'

Red Lines	
BEP35101	-3 AN x 12"
BEP35110	-4 AN x 8.5"
BEP35111	-4 AN x 12"
BEP35112	-4 AN x 18"

**MADE IN THE  
USA**

**POLISHED ALUMINUM FUEL CELLS**

- Made of aluminum and polished to a high finish
- Superior strength in a lightweight package
- Includes a flush-mount aircraft-style black cap
- Features a sump bottom
- Fitting sizes: -8 vent, -8 return, -8 outlets

BEP11205	5 Gallon Fuel Cell, 12" x 12" x 9.5"
BEP11210	10 Gallon Fuel Cell, 16.5" x 16.5" x 11"

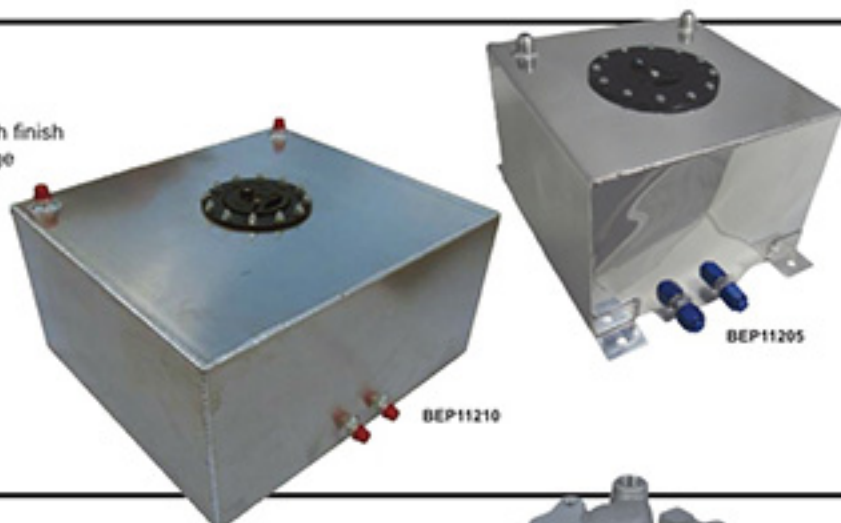
**SB CHEVROLET STREET/STRIP INTAKE MANIFOLD**

- Utilizes the latest casting and machining out there, which ensures a high quality, lightweight, performance intake manifold
- Features smoother intake runners for optimized fuel atomization and better distribution of fuel and air, producing more power
- RPM range: Idle to 6,000
- Port dimensions: 1.91" x 1.16"
- Manifold height: Front 4.29", Rear 5.31"

BEP18000	55-86 SB Chevy Intake Manifold
----------	--------------------------------

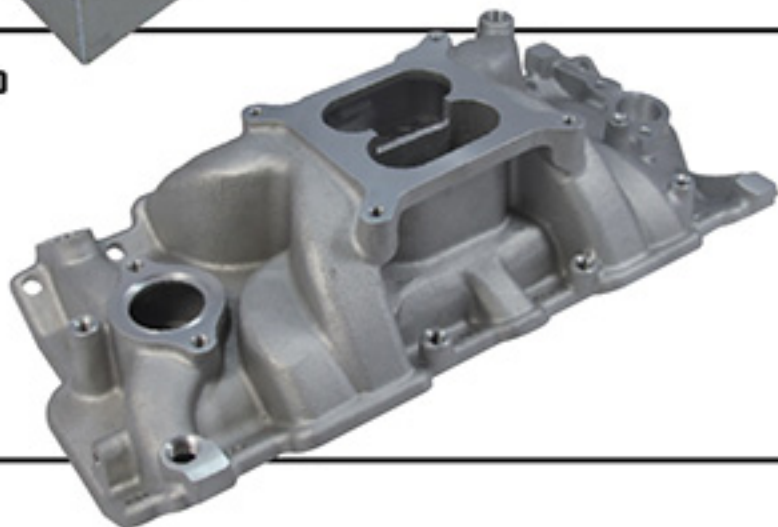
**EZ 2-HANDLE UTILITY JUGS**

- Heavy duty polyethylene construction
- 5-gallon capacity
- 2 handles make holding, pouring and transporting much easier

**MADE IN THE  
USA**

BEP40100	Utility Jug, White
BEP40101	Utility Jug, Red
BEP40102	Utility Jug, Black
BEP40106	Utility Jug Filler Hose
BEP40107	Utility Jug Replacement Cap

## SUPER COMP TACHOMETERS AND GAUGES

- All have chrome bezels and include a silver aluminum trim ring that snaps onto the bezel
- Mechanical gauges feature bronze bourdon tube movement for accuracy and durability and a wide 270° sweep for quick, precise readings. They also include proper tubing, adapter fittings and hardware
- Electrical voltmeters feature an 80° sweep and do not include wiring
- Tachometers feature peak RPM recall, a 270° full-sweep stepper motor, and have intense white through dial LED lighting



BEP15215 Tach, 5" 0-10,000 RPM, White  
BEP15216 Tach, 5" 0-10,000 RPM, White w/ Shift Light

BEP15205 Tach, 5" 0-10,000 RPM Black  
BEP15206 Tach, 5" 0-10,000 RPM Black w/ Shift Light

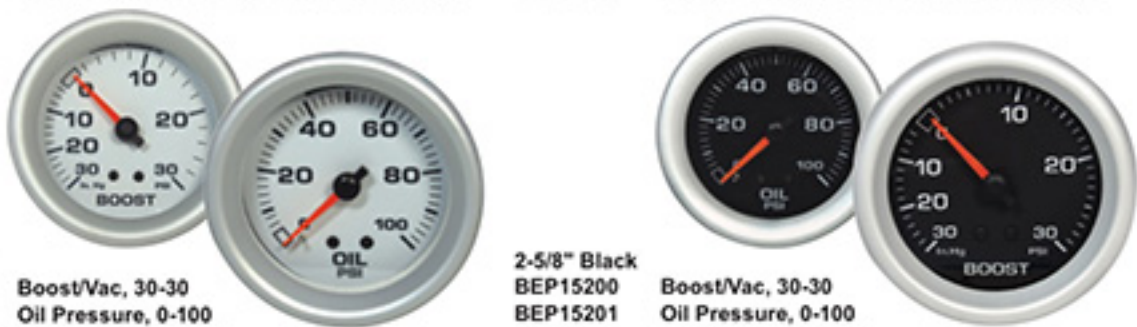

2-5/8" White  
BEP15210 Boost/Vac, 30-30  
BEP15211 Oil Pressure, 0-100  
BEP15212 Water Temp, 100-280  
BEP15213 Oil Temp, 100-280  
BEP15214 Volts, 8-18

2-5/8" Black  
BEP15200 Boost/Vac, 30-30  
BEP15201 Oil Pressure, 0-100  
BEP15202 Water Temp, 100-280  
BEP15203 Oil Temp, 100-280  
BEP15204 Volts 8-18

### TACHOMETER WITH SHIFT LIGHT

- Adjustable shift point indicator sets shift light
- 3-1/2" chrome bezel; black housing with backlit dial
- Used with conventional or electronic ignition system (except MSD or C.D. ignition systems)
- For use in 4-, 6- or 8-cylinder engines

BEP15000 0-8,000 RPM Shift Light Tach



### TACHOMETERS

- Adjustable center dial on face to set shift point indicator
- 3-1/2" chrome bezel with black housing and backlit dial
- Used with conventional or electronic ignition system (except MSD or C.D. ignition systems)
- For use in 4-, 6- or 8-cylinder engines

BEP15001 0-8,000 RPM Tach, Black Face with White Numbers  
BEP15002 0-8,000 RPM Tach, White Face with Black Numbers

**CARBON FIBER LOOK PRESSURE GAUGES**

- Stainless steel case
- Brass internals
- Silicone-filled
- 1/8" centered male NPT back mount

BEP15045 0-15 PSI  
 BEP15046 0-30 PSI  
 BEP15047 0-60 PSI  
 BEP15048 0-100 PSI

**MIDNIGHT BLACK PRESSURE GAUGES**

- Stainless steel case
- Brass internals
- Silicone-filled
- 1/8" centered male NPT back mount

BEP15016 0-15 PSI  
 BEP15017 0-30 PSI  
 BEP15018 0-60 PSI  
 BEP15019 0-100 PSI

**PRESSURE GAUGES**

- Chrome 1-1/2" diameter gauge
- Black face, white numbers
- Brass internals for long life
- 1/8" centered male NPT back mount

BEP15026 0-15 PSI  
 BEP15027 0-30 PSI  
 BEP15028 0-60 PSI  
 BEP15029 0-100 PSI

**LIQUID FILLED PRESSURE GAUGES**

- Chrome 1-1/2" diameter gauge
- Black face, white numbers
- Glycerin filled vibration protection
- 1/8" centered male NPT mount

BEP15020 0-15 PSI  
 BEP15021 0-30 PSI  
 BEP15022 0-60 PSI  
 BEP15023 0-100 PSI

**LIQUID FILLED PRESSURE GAUGES**

- Chrome 1-1/2" diameter gauge
- White face with black numbers
- Glycerin filled for vibration protection
- 1/8" centered male NPT mount

BEP15030 0-15 PSI  
 BEP15031 0-30 PSI  
 BEP15032 0-60 PSI  
 BEP15033 0-100 PSI

**LIQUID FILLED NITROUS PRESSURE GAUGES**

- Chrome 1-1/2" diameter gauge
- Available in black face or comp white
- Monitors bottle pressure, either on bottle or solenoid
- Glycerin filled for vibration protection
- 1/8" centered male NPT back mount

BEP15024 0-1500 PSI Black/Yellow Dial  
 BEP15025 0-1500 PSI Midnight Black  
 BEP15034 0-1500 PSI Comp White



**ENGINE-TURNED PRESSURE GAUGES**

- Chrome 1-1/2" diameter gauge
- Machined, engine-turned dial with black pointer
- Glycerin filled for vibration protection
- 1/8" centered male NPT back mount



BEP15040	0-15 PSI
BEP15041	0-30 PSI
BEP15042	0-60 PSI
BEP15043	0-100 PSI

**2-5/8" DIAMETER GAUGES**

- 2-5/8" large diameter, race styling for street performance
- Features full sweep dial with black face, white pointer and race-style chrome bezel mechanical gauges
- Come complete with adapters, tubing, light kit, mounting hardware and instructions



BEP15051	Voltmeter 10-18V
BEP15052	Fuel Pressure 0-15 PSI
BEP15053	Oil Pressure 0-100 PSI
BEP15054	Oil Temperature 100°-340°F
BEP15055	Vacuum 0-30 HG
BEP15056	Water Temperature 100°-280°F

**MULTI COLOR CONTROL TRIO GAUGE PANEL**

- Gauges are 2-1/16" with brushed aluminum bezels mounted in a chrome panel
- Installation hardware included
- Select from 7 different colors

BEP15083	Trio Panel, Mechanical, Water Temp, Oil Pressure and Voltmeter
----------	--

**2-5/8" CHROME GAUGE PANEL KITS**

- Feature a large 2-5/8" full sweep dial with black face, white pointer and chrome bezel in a chrome plated mounting panel
- All gauge panels come complete with adapters, tubing kit, light kit, mounting hardware and instructions

BEP15090	Dual Panel, Water Temp/Oil Pressure
BEP15091	Trio Panel, Water Temp/Oil Pressure/Ammeter

**2" GAUGE TRIO PANEL KITS**

- Feature 2" dia. mechanical gauges fully assembled in a panel
- All gauge sets include adapters, mounting hardware, light kit and instructions

BEP15080	Chrome Trio Gauges, Water/Oil/Amp
BEP15081	Black Trio Gauges, Water/Oil/Amp
BEP15082	Black Trio Gauges, Water/Oil/Volt

**2-5/8" GAUGE PANELS AND MOUNTING CUP**

- Chrome plated

BEP15100	Single Gauge Panel
BEP15101	Dual Gauge Panel
BEP15102	Triple Gauge Panel
BEP15110	Single Gauge Mounting Cup

**LIQUID FILLED ENGINE THERMOMETER**

- Can be mounted on an intake manifold or cylinder head for direct reading
- Glycerin filled for vibration protection
- Attaches to a 3/8" NPT fitting

BEP15015	Chrome, 2", 0°-250°F
----------	----------------------

**OIL PRESSURE GAUGE INSTALLATION KIT**

- Includes 72" of 1/8" nylon line and fittings

BEP15105	Oil Pressure Gauge Install Kit
----------	--------------------------------

**GAUGE SUPPLY LINE KITS**

- Comes with all necessary fittings
- Line rated to 3,000 PSI
- Stainless steel braided hose

BEP15120	-4 AN Line Kit 36"
BEP15121	-4 AN Line Kit 48"
BEP15122	-4 AN Line Kit 72"



**SFI ROLL BAR PADDING**

- High impact, high density
- 3' long sections, 1" thick
- Shaped to fit 1.50" to 1.75"
- SFI 45.1 approved.



- BEP27020 Black  
BEP27025 New-Style Lo-Profile

**ROLL BAR PADDING**

- Made of special closed cell foam
- Absorbs shock to prevent driver injury
- Fits 1.50" to 1.75" diameter tubing
- Flame retardant
- Not SFI approved



- BEP27000 Black  
BEP27001 Red  
BEP27002 Blue  
BEP27003 Yellow  
BEP27004 Orange  
BEP27005 Purple  
BEP27006 Gray

**RACER'S TAPE**

- Multi-purpose colored duct tape
- 2" x 180' rolls. Comes in 7 colors
- Tears straight and easy



- BEP27100 Red  
BEP27101 Blue  
BEP27102 Yellow  
BEP27103 Black  
BEP27104 Silver  
BEP27105 White  
BEP27107 Orange

**DIAL-IN BOARDS**

- ET dial-in boards are perfect to replace that messy shoe polish or vinyl cling numbers
- They feature pivoting numeral sections that allow you to adjust the dial-in quickly and easily



- BEP29500 4 Digit Velcro Mount and Suction Cups  
BEP29501 4 Digit w/ Mounting Holes  
BEP29502 3 Digit w/ Mounting Holes



**DIAL-IN MARKERS**

- Dry bright and wipe off easily with a dry rag
- Won't stain, so they can be used on painted surfaces, tires and even on Lexan windows



- BEP29600 White, 3oz.  
BEP29605 Yellow, 3oz.  
BEP29610 Orange, 3oz.  
BEP29620 White, 1 oz.  
BEP29625 Yellow, 1 oz.  
BEP29630 Orange, 1 oz.



**SEAT RISER BRACKET KIT**

- Gives you an extra inch of clearance
- Black powder coated

- BEP25002 Riser Bracket

**BIG END™**  
PERFORMANCE PRODUCTS  
**RACE TESTED & PROVEN!**

**SOUND AND HEAT BARRIER**

- Foil with butyl/rubber
- Choose silver or black
- Each package contains (9) 20"x29" sheets (36 sq. ft.)
- Easily trimmed with scissors or a utility knife
- Adheres to sheet metal, plastic and fiberglass
- Can withstand temperatures from -30° to 400°F

- BEP27500 Silver Barrier      BEP27510 Black Barrier

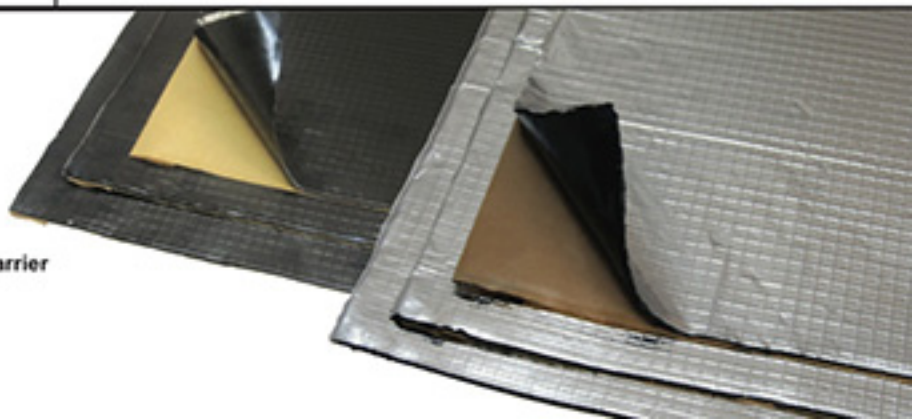



### PANEL FASTENER SPRINGS

- These springs anchor the whole fastening system
- To be used with all panel and self-eject fasteners
- Packaged in quantities of 10

1" Hole Spacing		1-3/8" Hole Spacing	
BEP26374	.200" Height	BEP26400	.325" Height
BEP26382	.325" Height	BEP26406	.375" Height
		BEP26412	.425" Height



### STEEL WELD FASTENER PLATES

- Fastener weld plates can be welded to any member of the vehicle to provide a pop rivet mount for fastener springs
- Many styles to choose for the best fabrication
- Packaged in quantities of 10

Part #	Pic.	Description
BEP26440	(A)	5/16" w/ 1" Spring
BEP26447	(B)	5/16" w/ 1" Spring
BEP26450	(C)	5/16" Self-Eject w/ 1" Spring
BEP26454	(D)	5/16" Self-Eject w/ 1" Spring
BEP26468	(E)	7/16" w/ 1-3/8" Spring
BEP26476	(F)	7/16" w/ 1-3/8" Spring
BEP26483	(G)	7/16" w/ 1-3/8" Spring
BEP26486	(H)	7/16" w/ 1-3/8" Spring
BEP26489	(J)	7/16" w/ 1-3/8" Spring, Corner Mount

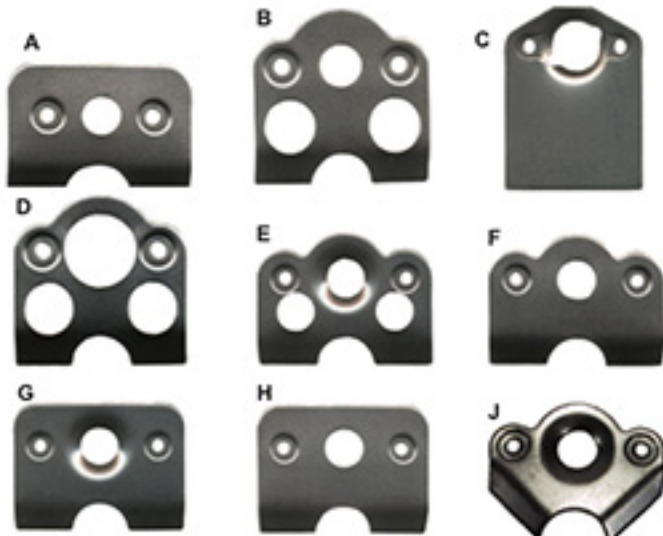

### QUARTER-TURN BUTTON WRENCH

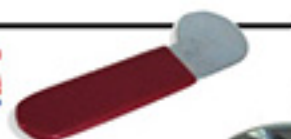

BEP41041 Quarter Turn Button Wrench

### PANEL FASTENERS

- Quick-turn cadmium plated fasteners used for all interior and exterior body panels
- Available in 4 body lengths and 3 head styles
- Packaged in quantities of 10

#### 5/16" Steel Fasteners

BEP26200	Oval Head .400" Short Body
BEP26205	Oval Head .500" Medium Body

#### 7/16" Steel Fasteners

BEP26225	Oval Head .500" Medium Body
BEP26231	Oval Head .550" Long Body
BEP26270	Flush Head .400" Short Body
BEP26274	Flush Head .450" Short Body
BEP26278	Flush Head .500" Medium Body
BEP26281	Flush Head .550" Long Body

#### 7/16" Winged

BEP26130	Winged Head .500" Medium Body
BEP26133	Winged Head .550" Long Body



### SELF-EJECT PANEL FASTENERS

- Quick-turn cadmium plated fasteners used on steel, aluminum and fiberglass body and interior panels
- Load force is distributed more evenly to prevent pull-through
- Spring-loaded fastener snaps out easily
- Packaged in quantities of 10

#### 5/16" Flush Head

BEP26320	.400" Short Body
BEP26324	.450" Short Body
BEP26327	.500" Medium Body
BEP26330	.550" Long Body



#### 5/16" Winged

BEP26100	.500" Medium Body
BEP26103	.550" Long Body
BEP26106	.600" Long Body
BEP26109	.650" Extra Long Body



#### 7/16" Flush Head

BEP26340	.500" Medium Body
BEP26346	.550" Long Body

## FASTENER TECHNICAL INFORMATION

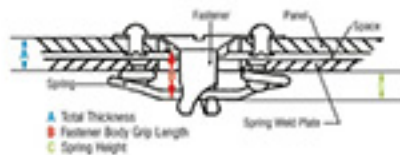

Determine the total thickness of panels being joined **A** including any space between panels.  
Then select the fastener grip length **B** and fastener spring height **C**.  
The combination will provide the desired thickness range on chart.

Button Grip Length <b>B</b> :		.400	.450	.500	.550	.600	.650	
1" Spring								
Spring Height <b>C</b>	Spring Part #			Total Thickness <b>A</b>				
	.250"	# 26374	.223-.258	.273-.308	.323-.358	.373-.408	.425-.458	.473-.508
	.325"	# 26382	.098-.133	.148-.183	.198-.233	.248-.283	.298-.333	.348-.383
1-3/8" Spring								
Spring Height <b>C</b>	Spring Part #			Total Thickness <b>A</b>				
	.325"	# 26400	.105-.148	.155-.198	.205-.248	.255-.298	.305-.348	.355-.398
	.375"	# 26406	.055-.098	.105-.148	.155-.198	.205-.248	.255-.298	.305-.348
	.425"	# 26412	.005-.048	.055-.098	.105-.148	.155-.198	.205-.248	.255-.298

Button Grip Length is the measurement from the bottom of head to the bottom of spring locking area on fastener.

**BRACKETS AND TABS**

- Designed for wide range of fabricating applications
- Weld-on style; packaged in different quantities

**Brake Tabs**

- BEP28114** Brake Line Tab, 5/8" Hole, .100" Steel, 3/4" Bottom to Center Hole, 4/pkg.  
**BEP28116** Brake Tab, 1/8" Steel, 5/16" Hole, 1-1/4", 4/pkg.

**Channel Fuel Cell Mounting Brackets**

- BEP28118** Channeled Fuel Cell, 1-3/8" W, 4-3/4" L, .085" Steel, 3/8" Hole, 1/pkg.  
**BEP28120** Channeled Fuel Cell, 1-3/8" W, 2" L, .085" Steel, 3/8" Hole, 1/pkg.

**Engine**

- BEP28124** Engine Stand Tab, 3/8" Steel, 1-3/8" L, 3/8" Hole, 1/pkg.  
**BEP28130** Transmission Mounting Bracket, 1/8" Steel, 1" x 7/16" Slot, 1/pkg.

**Front Suspension**

- BEP28152** A-Arm Mounts, 3/16" Steel, Fit 1-1/2" Tubing, 1/2" Hole, 1/pkg.

**Fuel**

- BEP28128** Fuel Pump Mount, 1/8" Steel, 11/32" Hole, 3" Center Between Holes, 1/pkg.

**Gussets**

- BEP28102** Std., 1/8" Steel Gusset, 1-7/8" L, 1/2" Hole, 100/pkg.  
**BEP28104** Std., 1/8" Steel Gusset, 1-7/8" L, No Hole, 100/pkg.  
**BEP28110** Mini Gusset, 1/8" Steel, 2" L, 1-1/2" Side Length, 1/pkg.  
**BEP28100** 3 Hole Gusset, 1/8" Steel, 1-3/4" Side Length, 100/pkg.

**Shock Spacer Mounts**

- BEP28160** Spacer Bushing, 1/2" Hole, 7/8" Long, Coil Over Mount, 1/pkg.

**Steel Frame Support Tabs**

- BEP28174** Round Support, 1-1/4" Dia., 1/8", 1/pkg.  
**BEP28178** Round Support, 1-3/4" Dia., 1/8", 1/pkg.

**Body Tabs**

- BEP28184** Body Tab, .085" Steel, 1/4" Hole, 1/pkg.  
**BEP28186** Body Tab, .085" Steel, 3/8" Hole, 1/pkg.  
**BEP28188** Body Tab, .085" Steel, 1/4" Hole, Flat, 1/pkg.

**Chassis Tabs**

- BEP28190** Chassis Tab, 3/16" Steel, 1/2" Hole, 1-3/4" Center to Edge, 1-1/2" Tubing, 1/pkg.  
**BEP28200** Chassis Tab, 3/16" Steel, 3/8" Hole, 1-1/4" from Center to Flat, 1/pkg.  
**BEP28202** Chassis Tab, 3/16" Steel, 1/2" Hole, 1-3/8" from Center to Flat, 1/pkg.  
**BEP28204** Chassis Tab, 1/8" Steel, 1/2" Hole, 1-3/8" from Center to Flat, 1/pkg.  
**BEP28206** H.D. Chassis Tab, 1/4" Steel, 1/2" Hole, 1-3/8" from Center to Flat, 1/pkg.  
**BEP28260** Chassis Tab, 3/16" Steel, 3/8" Hole, 1" from Center to Flat, 1/pkg.

**Seat Mounting Tabs, Center to Flat**

- BEP28208** 1/8" Steel, 1/2" Hole, 7/8", 1/pkg.  
**BEP28210** 3/16" Steel, 1/2" Hole, 7/8", 1/pkg.  
**BEP28212** 1/4" Steel, 1/2" Hole, 7/8", 1/pkg.



**BEP28214**



**BEP28224**



**BEP28184**



**BEP28130**



**Trick Tabs**

- BEP28214** Trick Tab, 1/8" Steel, 3/8" Hole, 1/pkg.  
**BEP28216** Trick Tab, 1/8" Steel, 1/2" Hole, 1/pkg.  
**BEP28218** Trick Tab, 1/8" Steel, 1/4" Hole, 1/pkg.

**Window Frame Tabs**

- BEP28220** Window Frame Tabs, 16 Ga. Steel, 3/16" Hole, 1" x 1" Steel, 1/pkg.  
**BEP28222** Window Frame Tabs, 16 Ga. Steel, 3/16" Hole, 3/4" x 3/4" Steel, 10/pkg.

**Body Tabs**

- BEP28224** Body Tab, .085" Steel, 1/4" Hole, 1/pkg.  
**BEP28226** Body Tab, .085" Steel, 3/8" Hole, 1/pkg.

**Skin Tab**

- BEP28228** Skin Tab, 1/8" Steel, 3/16" Hole, 1/pkg.

**90° Gusset Tab**

- BEP28230** 90° Gusset Tab, 1/8" Steel, 2" Long, Fits 1-1/2" Tubing, 3/8" Hole, 1/pkg.

**Parachute Tab**

- BEP28238** Parachute Tab, 1/8" Mild Steel, 3/8" Hole, 1-3/4" T, 1-1/8" Center to Flat, 1/pkg.

**Radius Tabs**

- BEP28232** 1/8" Steel, Fits 1-1/4" Tubing, 1-1/2" Long, 1/4" Hole, 1/pkg.  
**BEP28234** 1/8" Steel, Fits 1-1/4" Tubing, 1-1/2" Long, 3/8" Hole, 1/pkg.  
**BEP28244** 1/8" Steel, Fits 1-1/4", 1/4" Hole, 1/pkg.  
**BEP28258** 3/16" Steel, Fits 1-3/4" Tubing, 1/2" Hole, 1" Center Radius, 1/pkg.

**Bumper Tab**

- BEP28250** Bumper Tab, 1/8" Steel, 1/4" Hole, 1-1/4" Long, 15/16" Center to Flat, 1/pkg.

**Rear Wing Tab**

- BEP28254** Rear Wing Mounting Tab, 1/8" Steel, 1/4" Hole, 1-7/16" L, 7/8" from Center, 1/pkg.

**Rub Rail Flange**

- BEP28256** Rub Rail Flange, 3/16" Steel, 1-1/4" Dia. Large Center Hole, 3/8" Small Holes, 2-1/4" Center to Center Between Holes.

**Wing Tab**

- BEP28264** .046" Steel, Triangular w/ (3) 3/16" Holes

**HOOD PIN KIT**

- Hair pin style
- 1/2" x 4" chrome plated post with adjusting nuts
- 1-1/2" chrome plated scuff plates, hairpin clip and sheet metal screws
- Ideal for sheet metal and fiberglass hoods



BEP26000 Hood Pin Kit

**FLIP-OVER HOOD PIN KIT**

- Torsion style
- 1/2" x 4" chrome plated posts with adjusting nuts
- 1-1/2" scuff plates, flip-over safety pins and sheet metal screws
- Ideal for sheet metal and fiberglass body hoods



BEP26005 Hood Pin Kit, Flip Over Style

**REPLACEMENT PINS**

- Sold each



BEP26011 Hair Pin, Right and Left Pair  
BEP26012 Flip Over, Torsion Style

**LIGHTWEIGHT HOOD SPRINGS**

- Lightweight hood springs for bolt-on fiberglass hoods replace factory springs
- 2 styles of hood springs, sold each



BEP26030 Short Hood Springs

**HOOD PIN LANYARDS**

- 24" chrome plated plastic coated cables
- 2/pkg



BEP26025 Chrome Plastic Coated Lanyards

**SCUFF PLATES**

- Chrome plated metal
- Sold each



BEP26015 Scuff Plates

**ALUMINUM EPOXY COATED RIVETS**

- Aluminum body with steel mandrel
- Holds body panels tightly together
- 1/4" to 3/8" grip
- 250 per package



3/16" Small Dome Rivets	3/16" Large Dome Rivets
BEP24002 Silver	BEP24020 Silver
BEP24004 White	BEP24022 White
BEP24006 Black	BEP24024 Black
BEP24008 Red	BEP24026 Red
BEP24010 Blue	BEP24028 Blue
BEP24012 Yellow	BEP24030 Yellow
BEP24014 Orange	BEP24032 Orange

1/8" Small Dome Rivets
BEP24042 Silver, .003"-.125" Grip
BEP24044 Silver, .188"-.250" Grip

**CLECO PINS**

- Cleco pins allow easy installation and removal of sheet metal panels during mock-up fitting
- Reuseable pins work up to 1/4"



BEP24080 1/8", 10/pkg.	BEP24083 3/16", 10/pkg.
BEP24081 1/8", 25/pkg.	BEP24084 3/16", 25/pkg.
BEP24082 1/8", 100/pkg.	BEP24085 3/16", 100/pkg.

**CLECO PLIERS**

- Used to install and remove Cleco pins



BEP24088 Cleco Pliers

**TRI-FOLD RIVETS**

- 3/16" flange diameter, .062" thick
- Tri-fold type design for a large secondary expansion



BEP24050 Tri-Fold Rivet, Silver, 250/pkg.

**3/16" BACK-UP WASHERS**

- Prevents pull-through and provides a secure fitment



BEP24060 1/2" Dia. Medium, 500/pkg.
BEP24062 5/8" Dia. Large, 500/pkg.

**DOUBLE-END DRILL BITS**

- For rivets



BEP24070 1/8" Drill Bit Each
BEP24071 3/16" Drill Bit Each

## HIGH PERFORMANCE TORQUE CONVERTERS

- Big End high performance torque converters are the best value and quality converter made today
- Every HP torque converter features furnace brazed and welded impeller and turbine ID and OD fins
- TIG welded (except BEP32000 and 32002) Torrington bearings are used throughout the converter
- Features heat treated drive hub on impeller assembly, "Modified Blade" aluminum stator design, billet steel turbine hub, and are computer spin balanced
- All hubs, pads, splines, pilots and bushings are parallel, perpendicular and concentric to one another for a perfect fit and alignment, guaranteed
- All converters are factory tested for balance and pressure

## GM CONVERTERS

- Pump and turbine fins are TIG spot welded for extra strength
- Rebuilt sprag assembly. New pump hub
- Computer balanced



MADE IN THE  
**USA**



## FORD CONVERTERS

- Highest quality on the market
- New bearings between the stator and pump, rebuilt sprag assembly
- New pump hub, new turbine hub
- Pump and turbine TIG spot welded for extra strength
- Computer balanced, high pressure leak tested

## MOPAR CONVERTERS

- New Torrington bearings between stator and pump
- Rebuilt sprag assembly
- New pump hub
- New turbine hub, computer balanced



## FORD AOD TORQUE CONVERTERS

- Designed specifically for use with Ford automatic overdrive transmission
- Excellent performance and still retains the lockup feature
- Great choice for the 5.0L Mustang

## C-4 H.D. TORQUE CONVERTERS

- Primarily for highly modified and street-driven vehicles
- Excellent for short stroke 289-302-351W engines
- Recommended for 4:10-5:13 rear end ratios
- Proudly made in the U.S.A.



## XHD BIG NITROUS TORQUE CONVERTERS

- The Big End XHD (Extra Heavy Duty) torque converter features additional ballooning control and a 360° drive flange
- Steel billet turbine hub, heat-treated and finished ground splines, internal and external anti-ballooning plates, and mounting ring for high horsepower applications in excess of 650

## TORQUE CONVERTER APPLICATION CHART

MOPAR / CHRYSLER	11", 2300-2600 STALL	11", 2400-2800 STALL			
67-81 Torqueflite 727 non lock-up 24 spline 10" bolt circle	BEP32008				
FORD AOD	12", 2400-2800 STALL				
1980-up AOD 5.0L, 351W lock-up 11.4" bolt circle	BEP32012				
FORD C4	11", 2000-2400 STALL	11", 2200-2600 STALL	10", 2900-3300 STALL		
1970-up C4 10.5" bolt circle 26 spline, dipstick goes into trans case. 1.375" pilot	BEP32007		BEP32110 H.D. CONVERTER		
1970-up C4 11.4" bolt circle 26 spline, dipstick goes into trans case. 1.375" pilot			BEP32105 H.D. CONVERTER		
GM TURBO HYDROMATIC	12", 1900-2400 STALL	12", 2400-2800 STALL	10", 2800-3200 STALL	10", 3200-3500 STALL	10", 3200-3500 STALL
65-81 TH350, TH400 small bolt pattern (except lock-up)	BEP32002	BEP32000			
65-81 TH350, TH400 dual bolt pattern (except lock-up)			BEP32001 BEP32050 X.H.D. CONVERTER	BEP32003 BEP32055 X.H.D. CONVERTER	BEP32004 BEP32060 X.H.D. CONVERTER
GM TH700R4	12", 2000-2400 STALL	12", 2400-2800 STALL			
84-87 TH700R4 30 spline, lock-up dual bolt pattern (except LS1 / LS2)	BEP32016	BEP32017			

## SFI FLEXPLATES

- SFI Approved for all racing classes in NHRA or IHRA that require an SFI stickered flexplate
- 0.35" thicker than stock, double-welded ring gear
- Double drilled for large and small converter patterns
- All SFI flywheels are zinc plated for moisture resistance; SFI 29.1 approved

BEP34000	SB/BB Chevy Int. Balanced 168T, 2-pc. Rear Main 55-88
BEP34002	SB 400 Chevy Ext. Balanced 168T, 2-pc. Rear Main 70-80
BEP34004	BB Chevy Ext. Balanced 168T, Up to 90
BEP34006	SB Chevy Int. Balanced 153T, 2-pc. Rear Main Up to 88
BEP34008	SB Chevy Ext. Balanced 168T, Late 1-pc. Rear Main 89-98



## OEM REPLACEMENT FLEXPLATES

- Big End automatic OEM flexplates are a direct replacement of the stock units
- Provides the same high quality performance as the original



BEP34001	SB/BB Chevy Int. Balanced 168T 2-pc. Rear Main 55-88
BEP34003	SB Chevy 400 Ext. Balanced Rear Main 70-80
BEP34005	BB Chevy Ext. Balanced 168T 2-pc. Rear Main, Up to 90
BEP34007	SB Chevy Int. Balanced 153T 2-pc. Rear Main 55-88



### REAR END GIRDLES

- All girdles are made of 356 aircraft grade aluminum, heat treated to T6 specifications, each cover is then stress relieved
- Fill port and drain port for ease of servicing
- Show a decrease in operating temperature, average of 15°F
- Weigh about 9.5 lbs.
- Improves undercarriage appearance



Ford		Dana	
BEP31805	7.5"	BEP31812	Dana 60
BEP31806	8.8"	BEP31813	Dana 70
GM		Cap Stud Kits	
BEP31807	10-Bolt, 8.5"	BEP31815	GM Kit
BEP31808	10-Bolt, B.O.P.	BEP31816	Ford/Dana Kit
BEP31809	10-Bolt, 7.5"		
BEP31810	12-Bolt, Car		
BEP31811	12-Bolt, Truck		

### FULL LIGHTWEIGHT STEEL SPOOLS

- Manufactured from 4140 chrome-moly forgings
- Machined and lightened by state of the art CNC machinery to exact specifications
- Permanently locks both axles together to keep tires at same speed
- For all drag race and circle track applications

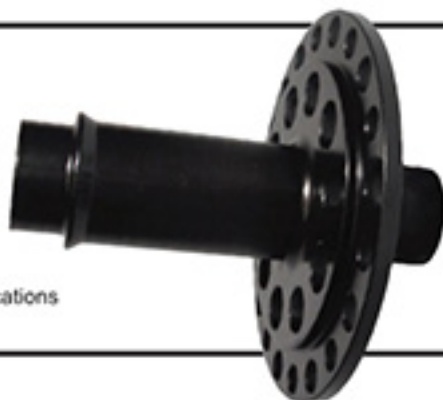

	Bearing I.D.	Axle Spline
Ford 9"		
BEP31001	3.062"	28
BEP31003	3.062"	31
BEP31006	3.250"	35
GM 12, Bolt 3.90 and Up, 4-Series Carrier		
BEP31000	Standard	30

### MINI SPOOLS

- Manufactured of 8620 non-leaded steel
- Replaces OEM spider gears in open carrier units, locking together both axles for even power to both tires
- Used mostly in drag racing and dirt oval track
- Machined by state of the art CNC machinery to exact specifications
- Fits open series carriers only
- GM 7.5 fits 3.08 and up carrier only



	Make	Carrier	Spline
BEP31020	GM	10-bolt 8.5	28
BEP31023	GM	10-bolt 7.5	26
BEP31024	Ford	8.8	28
BEP31025	Ford	8.8	31
BEP31026	Ford	9.0	28
BEP31027	Ford	9.0	31

### CROSS PIN

- Made of 4140 chrome-moly steel
- A must when using mini spool in oval track applications



BEP31042 9" Ford Cross Pin



### RING GEAR SPACER

- Made of high quality steel
- Fits GM 7.5" 10-bolt differentials
- Includes Grade 8 bolts

BEP31030 Ring Gear Spacer Kit 7.5" GM



**BIG END**<sup>™</sup>  
PERFORMANCE PRODUCTS  
**RACE TESTED & PROVEN!**

## RING AND PINION SETS

- Designed for street, moderate strip and circle track applications
- Forged steel is heat-treated for added strength and Rockwell tested for correct hardness
- Machined to the tightest tolerances in the industry

### FORD 9" GEAR SETS

- Fits 62-87 Ford 9", 11-3/4" oval housing
- 10-bolt ring gear
- 9.00" ring gear diameter, 1.313" pinion diameter
- 28 spline pinion

	Ratio	Teeth
BEP30000	3.50	35-10
BEP30040	3.70	37-10
BEP30001	3.89	35-9
BEP30002	4.11	37-9
BEP30003	4.57	32-7
BEP30005	5.14	36-7
BEP30006	5.43	38-7
BEP30007	5.67	34-6
BEP30008	5.83	35-6
BEP30009	6.00	36-6
BEP30010	6.20	31-5
BEP30045	6.33	38-6
BEP30011	6.50	39-6



#### YOU MAY ALSO NEED:

Mini Spool	Axle Spline
BEP31026	28
BEP31027	31

Installation Kit	
BEP30125	Open
BEP30127	3.062" Bearing

Lightweight Spool	
BEP31001	3.062" 28
BEP31003	3.062" 31
BEP31006	3.250" 35

Cross Pin	
BEP31042	Chrome-Moly Cross Pin

### FORD 8.8" GEAR SETS

- All 85-up V8 Ford Mustangs, 81-02 trucks, 82-up full size cars and 87-97 Thunderbirds
- 10-bolt rear cover
  - 8.8" diameter ring gear
  - 1.626" pinion diameter
  - 30 spline pinion

	Ratio	Teeth
BEP30050	3.55	39-11
BEP30052	3.73	41-11
BEP30054	4.10	41-10



#### YOU MAY ALSO NEED:

Mini Spool	Axle Spline
BEP31024	28
BEP31025	31

Installation Kit	
BEP30120	Ford 8.8" Gear

### GM 7.5" GEAR SETS

- All 77-02 GM models, 82-02 Camaro and Firebird, and 83-02 S-10 pickups
- 8-5/16" x 10-9/16" oval cover, 10 bolt rear cover
  - 7.5" diameter ring gear fits most 7.5 and 7.625" applications
  - 1.438" pinion diameter, 27 spline

	Ratio	Teeth	Carrier
BEP30026	3.42	41-12	3
BEP30012	3.73	41-11	3
BEP30014	4.10	41-10	3



#### YOU MAY ALSO NEED:

Mini Spool	Axle Spline
BEP31023	26
Installation Kit	
BEP30105	GM 10 Bolt, 7.5" Gear 80-96
	Ring Gear Spacer
BEP31030	Gear Spacer Kit 7.5" GM

### GM 8.2" GEAR SET

All 64-72 Chevy, Camaro, Chevelle, Nova.

- 11" oval, 10 bolt rear cover
- 8.20" diameter ring gear
- 1.438" pinion diameter, 25 spline
- Will not fit B.O.P.



	Ratio	Teeth	Carrier
BEP30016	4.11	37-9	3

#### YOU MAY ALSO NEED:

Installation Kit  
**BEP30117** GM 10 Bolt, 8.2" Gear Chevy 64-71

### GM 8.5" GEAR SETS

All 70-81 GM cars, all 77-02 GM trucks (check ring gear size).

- (A)11" irregular 10-bolt rear cover
- (B)10 5/8" irregular 10-bolt rear cover
- 8.50" diameter ring gear
- 1.625" pinion diameter
- 30 spline pinion



#### YOU MAY ALSO NEED:

Mini Spool Axle Spline  
**BEP31020** 28  
 Installation Kit  
**BEP30100** GM 10 Bolt, 8.5" Gear 73-97

	Ratio	Teeth	Carrier
BEP30017	3.42	41-12	3
BEP30018	3.73	41-11	3
BEP30020	4.11	41-10	3
BEP30021	4.56	41-9	3

### GM 8.875" CAR GEAR SETS

All 12-bolt passenger cars 65-72.

- 10-7/8" oval 12-bolt rear cover
- 8.875" diameter ring gear, 1.625" diameter, 30 spline pinion

	Ratio	Teeth	Carrier
BEP30027	3.42	41-12	3
BEP30022	3.73	41-11	3
BEP30024	4.10	37-9	4
BEP30025	4.56	41-9	4



#### YOU MAY ALSO NEED:

Lightweight Steel Spool Axle Spline  
**BEP31000** 30

Installation Kit  
**BEP30115** GM 12 Bolt, 8.875" Gear Auto

### COMPLETE INSTALLATION KITS

- Complete with Timken® bearings
- Kit includes: Pinion and carrier bearings, pinion nut and washer, pinion seal, pinion and carrier shims, crush sleeve, ring gear bolts and washers, marking compound and brush, tube of silicone sealer, and red thread locker
- Ford 9" includes pilot bearings

BEARINGS  
 MANUFACTURED BY:  
**TIMKEN**



#### Passenger Car

**BEP30100** GM 10-Bolt, 8.5" Gear 73-97  
**BEP30105** GM 10-Bolt, 7.5" Gear 80-96  
**BEP30117** GM 10-Bolt, 8.2" Gear Chevy 64-71  
**BEP30130** GM 10-Bolt, 8.2" B.O.P. 64-71  
**BEP30115** GM 12-Bolt, 8.875" Gear Auto  
**BEP30120** Ford 8.8" Gear  
**BEP30125** Ford 9" Open, 2.891" Bearing  
**BEP30127** Ford 9" 3.062" Bearing w/ Solid Pinion Spacer (No Crush Sleeve)

#### Truck

**BEP30100** GM 10-Bolt, 8.5" Gear C/K 1/2 Ton 73-97  
**BEP30105** GM 10-Bolt, 7.5" 7.625" Gear S-10, S-15 82-92  
**BEP30120** Ford 8.8" Gear 1/2 Ton Trucks, Vans 83-90  
**BEP30125** Ford 9" Open 1/2 Ton Trucks 71-88, 2.891" Bearing  
**BEP30127** Ford 9" 3.062" Bearing 1/2 Ton Trucks 57-70 w/ Solid Pinion Spacer (No Crush Sleeve)



**WHEEL VALVE STEMS AND CAPS**

- Chrome plated, quality finish adds the classic look to mag wheels
- Pull-through or bolt-in styles
- Chrome caps included or sold separately
- 2 per package



BEP20201  
BEP20220

Pull-Through Chrome Valve Stem  
Chrome Valve Stem Cap (4 per bag)

**TIRE PRESSURE GAUGES**

- 2-5/8" diameter dial
- Protective rubber bezel
- 13mm hose with air check valve

BEP15151 0-15 PSI  
BEP15152 0-30 PSI  
BEP15153 0-60 PSI

**ALUMINUM WHEEL SPACERS**

- Universal 3/8" thick die-cast aluminum
- 5-hole 4-1/2, 4-3/4, 5" bolt circles
- 2/package



BEP20110 Disc Brake Spacers 3/8" Thick (Pair)

**WHEEL RIM SCREWS**

- Grade 8 quality, self-tapping screws
- Anchors tire on rim, prevents spinning
- Built-in washer face
- Uses a 3/8" hex socket driver
- 35 per package



BEP65200 Wheel Rim Screws

**BILLET LINE CLAMPS**

- Secure and dress up your lines, cables or wiring with our 2-piece billet line clamps
- Designed to securely hold all of your wiring and hardline, and allow you to bolt them directly to the frame or firewall



BEP22100 3/16", 4/pkg. BEP22102 5/16", 4/pkg.  
BEP22101 1/4", 4/pkg. BEP22103 3/8", 4/pkg.

**DRIVESHAFT SAFETY LOOP**

- Made of heavy gauge steel; fully adjustable
- Universal mounting, hardware included
- Zinc-plated for rust prevention

BEP28000 Driveshaft Safety Loop



**MADE IN THE USA**

**BILLET WHEELIE-BAR WHEELS**

- Made from solid billet 6061-T6 aircraft grade material
- Molded with a polyurethane material that won't dent or give like a rubber wheel can
- Over a 10,000 lbs./ft. load capacity
- 4" O.D., 3/8" through hole for mounting
- Track tested and run on vehicles making over 1,500 HP

BEP29100 Star Style Wheels  
BEP29105 Hole Style Wheels

**CIRCLE TRACK WHEEL STUDS**

- Manufactured from high-grade steel; shearloads greater than Grade 8 specs
- For use in circle track applications where 1" or thicker wheel is used, and rules require an exposed wheel stud past the lug nut
- Press-in wheel studs feature strong knurls for press fit; sold each



BEP20320 5/8"-11 x 2-3/4" Long, .690" Knurl, .850 Shoulder Length, Coarse Threads, Oval Track Use, Quick Start End, 1/pkg.  
BEP20322 5/8"-11 x 2-3/4" Long, .690" Knurl, .375 Shoulder Length, Coarse Threads, Oval Track Use, Quick Start End, 1/pkg.

MANUFACTURED BY:  
**POWER PLUS**



**FUEL FRAGRANCES**

- Eliminates unpleasant exhaust fumes and the eye, nose and throat irritation that comes from your alcohol or gasoline fueled vehicle. Just mix it in with your fuel  
- (1) 4-oz. bottle will treat 30 gallons of alcohol or 20 gallons of gas

BEP17119	Cherry	BEP17145	Root Beer
BEP17132	Grape	BEP17146	Hawaiian Punch
BEP17136	Strawberry	BEP17147	Pina Coloda
BEP17139	Cinnamon	BEP17148	Watermelon
BEP17141	Raspberry	BEP17149	Cotton Candy
BEP17142	Banana	BEP17150	Apple
BEP17143	Vanilla	BEP17152	Blueberry
BEP17144	Bubble Gum	BEP17153	Tangerine
		BEP17171	Reefer Madness

**TIRE SOFTENERS**

- Reduces lap times 2-5 tenths, corner speeds increase 3-5 MPH  
- Increases tire life up to 50%  
- Victory Lap traction treatment is detectable, Hot Lap is not



BEP20420	Victory Lap, 1 Gal.
BEP20430	Hot Lap Pro Bite, 32 oz.

**POWER PLUS LUBE**

- Eliminates cylinder washdown and excessive wear  
- Mix it in with your fuel. (1) 16-oz. bottle treats up to 55 gallons



BEP17018	Cherry
BEP17031	Grape
BEP17035	Strawberry
BEP17037	Unscented, Clear
BEP17038	Unscented, Blue

**WHEELIE BAR CHALK**

- Designed to leave bright solid marks on the track to help tune your chassis to perfection  
- Features a special applicator that ensures the correct amount is applied to each wheel

BEP29210	White
BEP29215	Yellow
BEP29220	Orange

MANUFACTURED BY:  
**CI**  
Clear One



MANUFACTURED BY:  
**POWER PLUS**



**TRACKBITE**

- Custom formulated resin that provides controlled traction for competition racing  
- Liquid track and tire treatment, improves traction on asphalt and concrete surfaces

BEP20400	TrackBite, 1 Gal.
----------	-------------------

MANUFACTURED BY:  
**PJ1**

**WHEELY BAR SPRAY CHALK**

- Unique, easy to clean aerosol coating  
- Wheely Bar Chalk was developed to replace messy and hard to clean shoe polish

BEP29200	White Spray Chalk
----------	-------------------



MANUFACTURED BY:  
**PJ1**





### SMALL BLOCK CHEVY STREET/STRIP OIL PANS

- 7 quart capacity with kick-out sump
- Painted, stamped steel with a welded wide base provides additional ground clearance
- Fit most GM chassis (ex. 62-67 Chevy II V-8 Monza/Vega)
- Sump size: 8-1/4" from pan rail, 10-1/4" W x 9-1/2" L
- Requires BEP43019 Oil Pump Pickup

BEP43008	55-79 SBC w/ L.H. or D.S. Dipstick (except 62-67 Nova II), Orange
BEP43012	80-85 SBC w/ R.H. or P.S. Dipstick, Orange
BEP43013	86-up SB Chevy 1-pc. Rear Main Seal, Black
BEP43019	Required Oil Pump Pickup

### BIG BLOCK CHEVY STREET/STRIP OIL PAN

- 7 quart capacity with kick-out sump
- Stamped steel with a welded wide base provides additional ground clearance
- Fit most GM chassis (except 62-67 Chevy II V-8 Monza and Vega)
- Sump size: 8-1/4" from pan rail, 10-1/4" W x 9-1/2" L
- Requires BEP43016 Oil Pump Pickup

BEP43011	65-92 BB Chevy Street/Strip Oil Pan, Orange
BEP43016	Recommended Oil Pump Pickup

**Installation advisory:**  
Will not fit stroker motors or aluminum rod engines.

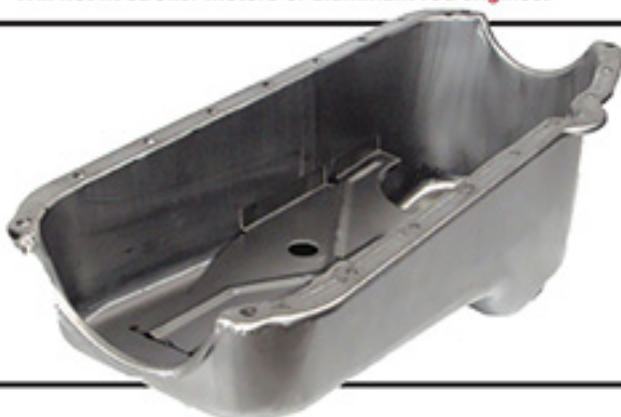

### STOCK OEM REPLACEMENT OIL PANS

- Each pan is stamped to OEM specs
- Corner bolt reinforcement tabs
- Factory baffle for stock oil pump location, stock depth

BEP43000	55-79 SB Chevy w/ L.H. or D.S. Dipstick
BEP43001	80-85 SB Chevy w/ R.H. or P.S. Dipstick
BEP43002	86-up SB Chevy w/ 1-pc. Rear Main Seal
BEP43020	65-92 Big Block Chevy
BEP43040	65-87 SB Ford Pass. Car, Front Sump
BEP43041	83-93 Ford Mustang 5.0 Dual Sump Pan (Not for Trucks or Vans)

### PRO SERIES OIL PAN: SMALL BLOCK CHEVROLET

- Fits Dart SHP block
- Cleared for up to 3.75 stroke
- 5.5 quart capacity
- Built in windage screen, crank scraper and declaration ledge
- Magnetic drain plug
- Drag race baffling

BEP44010	SBC 80-85 2-pc. Seal Drag Pan, PS Dipstick
----------	--



### PRO SERIES OIL PAN: GM CHASSIS

- Cleared for up to 3.875 stroke
- 5.5 quart capacity
- Built in windage screen, crank scraper and declaration ledge
- Magnetic drain plug
- Drag race baffling

BEP44015	SBC 87-up 1-pc. Rear Seal, PS Dipstick
----------	--

**PRO SERIES OIL PAN: SMALL BLOCK CHEVELLE AND CAMARO**

- Cleared for up to 3.75 stroke
- 5.5 quart capacity
- Built in windage screen, crank scraper and declaration ledge
- Magnetic drain plug
- Drag race baffling

BEP44005 SBC 55-79 2-pc. Rear Seal Drag Pan, DS Dipstick

**PRO SERIES OIL PAN: SMALL BLOCK GM CHASSIS**

- Cleared for up to 3.875 stroke
- 5.5 quart capacity
- Built in windage screen, crank scraper and declaration ledge
- Magnetic drain plug
- Drag race baffling

BEP44000 SBC 55-79 2-pc. Drag Pan, DS Dipstick

**PRO SERIES OIL PAN: BIG BLOCK CHEVELLE AND CAMARO**

- Cleared for up to 4.25 stroke
- 6 quart capacity
- Built in windage screen, crank scraper and declaration ledge
- Magnetic drain plug
- Drag race baffling

BEP44100 BBC 65-90 2-pc. Rear Seal Drag Pan

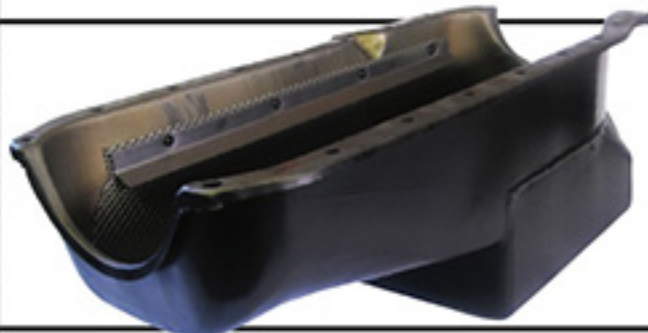
**PRO SERIES OIL PAN: BIG BLOCK GM CHASSIS**

- Cleared for up to 4.25 stroke
- 6 quart capacity
- Built in windage screen, crank scraper and declaration ledge
- Magnetic drain plug
- Drag race baffling

BEP44105 BBC 65-90 2-pc. Rear Seal Drag Pan

**PRO SERIES OIL PAN: GEN V / VI**

- Cleared for up to 4.25 stroke
- 6 quart capacity
- Built in windage screen, crank scraper and declaration ledge
- Magnetic drain plug
- Drag race baffling

BEP44110 BBC 1-pc. Rear Seal Drag Pan

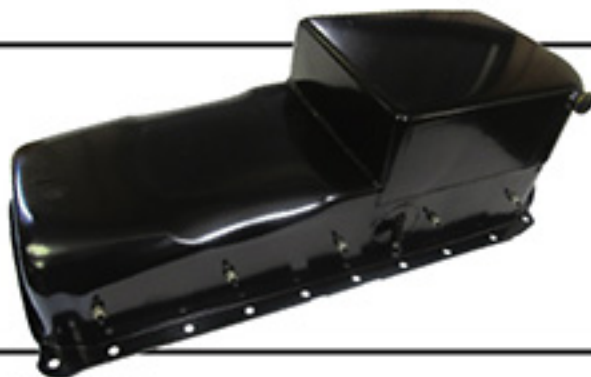
**OIL PUMP PICKUPS**

- Designed to meet the depth requirements of the pan, maintain proper pickup to pan floor clearance and fit within the baffle constraints
- Fixture heli-arc welded
- Includes heavy gauge boxes, high flow rate filtering screen and support brackets as required

BEP44200 SBC Standard Volume, 7"-8"-9"-10"  
 BEP44205 SBC High Volume, 7"-8"-9"-10"  
 BEP44210 BBC Standard Volume, 7"-8"-9"-10"  
 BEP44215 BBC High Volume, 7"-8"-9"-10"

**OIL RESTRICTOR**

- Big End oil galley restrictors sit flush in the block and do not interfere with any motor plates, flywheels or flexplates like some other hex head restrictors do
- Features a 0.060" orifice, 1/4" NPT threads and a 5/16" socket head
- Made from stainless steel. Fits early and late SB/BB Chevy blocks including bowtie
- Not for use with hydraulic lifters



BEP48300 Oil Restrictor SS .060" Chevy, Pair

**OIL PUMP DRIVESHAFTS**

- Big End Performance oil pump shafts are the perfect choice when looking for a new oil pump drive for your performance engine. Made from high grade alloy steel and provides far greater strength than OEM shafts

BEP44250 SB Chevy Shaft  
BEP44255 BB Chevy Shaft

**CHEVY OIL FILTER ADAPTER**

- Replaces the factory GM oil filter adapter #3952301
- Includes oil bypass valve and mounting bolts
- Fits Chevy V8 engines using a spin-on filter (Wix 51069, AC PF25, Moroso 22459) from 1968 to 1986



BEP48000 Chevy Oil Filter Adapter

**FRONT MOTOR PLATES**

- CNC-machined from 1/4" 6061-T6 aluminum for a precision fit
- Prevent movement and allow for the engine to be mounted in the original location or setback
- 1-piece design ideal for most drag and circle track cars
- Requires trimming to size



BEP42100 SB Chevy Plate  
BEP42105 BB Chevy Plate

**ALLEN HEAD TIMING CHAIN COVER BOLT KIT**

- Grade 5 Allen head bolts
- Zinc plated to resist rust and corrosion



BEP65150 Timing Chain Cover Bolts, SB and BB Chevy

**TIMING CHAIN COVER BOLT KIT**

- 1/4"-20 x 1/2", hex head flange
- Serrated under bolt head
- Zinc plated to resist rust and corrosion



BEP47320 Timing Cover Bolt Kit SBC/BB 1/4"

**CHROME STEEL MAGNETIC DRAIN PLUG**

- Chrome plated with 1/2"-20 standard thread
- Nylon washer included



BEP43025 Chrome Steel Magnetic Drain Plug

**TIMING CHAIN COVERS**

- New OE style replacement.
- Raw steel, ready to paint.



BEP43120 Small Block Chevy  
BEP43125 Big Block Chevy  
BEP43150 Heavy Duty Small Block Chevy

**POLISHED ALUMINUM TIMING CHAIN COVERS**

- Also gives added support to timing chain and camshaft area
- Fits all standard, double roller timing chain sets and some gear drives
- Short water pumps will not fit when using this cover
- New 2-piece timing chain cover allows for quick and easy cam swaps without having to break the oil pan seal



BEP70082 SB Chevy  
BEP70083 BB Chevy  
BEP70081 SB Chevy 2-pc. Cover

**LIFTER VALLEY VENTS**

- Machined from 6061-T6 aluminum and designed to help prevent oil drain back on your reciprocating assembly, reduce windage and free up horsepower in the process
- OEM vent holes must be tapped to 1/4" NPT
- Complete set of 8



**MADE IN THE USA**

BEP48315 Lifter Valley Vents

**DOWEL PINS**

- These precision manufactured dowel pins are available for SB Chevy, BB Chevy and SB Ford
- Sold in sets of 4



BEP48011 SB Chevy 4/pkg.  
BEP48012 BB Chevy 4/pkg.  
BEP48015 SB Ford 4/pkg.



APPLICATION SHOWN MAY DIFFER OR NOT BE SHOWN WITH MODIFICATIONS

**CRANKCASE EVACUATION SYSTEM**

- Reduces pressure build-up in the engine crankcase
- Complete kit includes 2 Mopar style breathers, grommets, check valves, tubes and clamps

BEP70360 Crankcase Evacuation System

**CHEVY CAM BUTTONS**

- Prevent the cam from walking back and forth in the block, giving you more accurate timing and longer timing chain life
- Install with a standard cam lock plate such as BEP48220

**Roller Cam Buttons**

BEP48100 SB Chevy 265-400 .795" Long

BEP48105 BB Chevy 396-502 .940" Long

**Aluminum Buttons**

BEP48200 SB Chevy (Flat Timing Cover)

BEP48205 SB Chevy (Indented Timing Cover)

BEP48210 BB Chevy

**CHEVY CAMSHAFT LOCK PLATE AND BOLT KIT**

- The steel plate installed by bending the tabs against the hex head Grade 8 bolts
- This prevents the bolt from loosening
- Black oxide finish
- Will not fit engines with factory roller cams



BEP48220 Chevy Lock Plate and Bolt Kit

**BILLET ADJUSTABLE TIMING POINTERS**

- CNC-machined aerospace aluminum alloy
- Adjustable pointer + or - 4°
- Black anodized
- Mounting bolts included



**MADE IN THE USA**

BEP70400 SB Chevy 6-1/4" Fluidampr  
BEP70401 SB Chevy 6-1/8"  
BEP70402 SB Chevy 6-3/8" ATI Balancer  
BEP70403 SB Chevy 6-3/4"  
BEP70408 SB Chevy 7-1/4" Fluidampr  
BEP70410 SB Chevy 8" Fluidampr  
BEP70412 BB Chevy 6-1/4" Fluidampr  
BEP70414 BB Chevy 7" Balancer  
BEP70415 BB Chevy 7-1/4"  
BEP70418 BB Chevy 8" Fluidampr  
BEP70420 SB Ford, All Timing Positions

**TIMING TAPE**

- Designed for high performance engines to make sure your engine is on time
- The degree marking range is from 60 BTDC to 0 TDC



BEP70430 SB Chevy, 6"  
BEP70431 SB Ford, 6.375"  
BEP70432 SB Chevy, 6.75"  
BEP70433 BB Chrysler, 7.250"  
BEP70434 SB/BB Chevy, 8"

**CHEVY SOLID STEEL MOTOR MOUNTS**

- Made of 1/4" thick steel; 3-hole mounting 2-1/16" wide, 1-11/16" tall. Center bolt hole to flat
- Black powder coating. Sold in pairs

**MADE IN THE USA**



BEP42000 Chevy Motor Mounts

**HIGH QUALITY PRODUCTS  
PRICED RIGHT!**

**PILOT BUSHINGS**

- Both are designed to help keep heat down, while the roller bushing reduces friction, providing quicker, smoother shifts
- Designed to fit Chevrolet, Olds and Buick applications with a 1.093" OD and a .591" ID

BEP48050 GM HD Bronze Pilot Bushing  
 BEP48055 GM HD Roller Pilot Bearing

**CRANK KEYS**

- Heat treated to minimize wear
- Available for Chevy engine in either a long or short style. Sold in pairs

BEP48020 Chevy Crank Keys, Short  
 BEP48021 Chevy Crank Keys, Long

**HEX HEAD ENGINE FASTENER KITS**

- Chevy kits include: timing cover, oil pan, fuel pump, header, water neck, intake manifold, distributor, valve cover and water pump bolt sets (on SBC, short pump only). Includes washers
- SB Ford kits include: timing cover, oil pan, fuel pump, header, filler neck, intake manifold and valve cover bolt sets. Includes washers



Polished Stainless Steel

BEP47400 Engine Bolt Kit, SB Chevy  
 BEP47405 Engine Bolt Kit, BB Chevy  
 BEP47410 Engine Bolt Kit, SB Ford

Stainless Steel

BEP47420 Engine Bolt Kit, SB Chevy  
 BEP47425 Engine Bolt Kit, BB Chevy

**GUIDE PLATES**

- Designed and manufactured for precise fit and function
- Heat treated, black oxide
- Requires the use of hardened pushrods
- Cylinder head machining and screw-in rocker arm studs may be required for installation
- Made in USA. Sold 8/pkg



BEP47056 SB Chevy Flat 5/16" Plate  
 BEP47059 SB Chevy Raised 5/16" Plate

**H/P HEAD BOLT KITS**

- Heat treated to 180,000 PSI and feature rolled threads and reduced size 12 pt. heads for increased valve spring pocket clearance
- Extended thread length distributes torque stretch for increased clamping force
- Extra thick hi-tensile and chamfered washers are included



BEP47551 SB Chevy Kit  
 BEP47556 BB Chevy Kit

**HEAD BOLTS**

- Grade 9 material
- Cold headed 6-point heads, rolled threads and PTFE sealer
- Each kit contains bolts for a complete engine



BEP47550 SB Chevy Kit  
 BEP47555 BB Chevy Kit

**ENGINE ACCESSORY STUDS**

- All studs are made from 150,000 PSI material and feature a hex head but with captive washer and a bullet nose for easier starting



Timing Cover Studs  
 BEP47540 SB/BB Chevy Kit

**BALANCER BOLT KITS**

- Feature a 180,000 PSI hi-tensile hex head bolt with an extra thick parallel ground washer for more uniform torque and a hi-tensile lock washer



BEP47570 SB Chevy Kit 7/16"-20  
 BEP47575 BB Chevy Kit 1/2"-20

**BIG END**<sup>™</sup>  
 PERFORMANCE PRODUCTS  
**RACE TESTED & PROVEN!**



**ENGINE CRADLES**

- Ideal for engine storage or transportation
- Breaks down for easy storage
- Made of 14-gauge square tubing
- Black powder coated
- 2 models: standard, to be used without wheels; heavy duty, wheels can be added (H.D. models only)
- BEP40022 comes complete with wheels as added value

- BEP40020 Chevy V8 Standard
- BEP40021 Chevy V8 HD
- BEP40022 Chevy V8 with Wheels
- BEP40023 Ford V8 289-351W Standard
- BEP40025 Pontiac HD
- BEP40026 Chrysler V8 383-440 Standard
- BEP40027 Chrysler V8 318-360 Standard
- BEP40029 Ford V8 429-460 Standard
- BEP40031 Olds V8 1964-1976 Standard



**ENGINE LIFT PLATE**

- Fits all 2bbl, 4bbl and Dominators
- Heavy gauge steel with 3 hook positions. Zinc-plated

BEP40009 Engine Lift Plate



**SAFETY WIRE AND PLIERS**

- 9" safety wire pliers can be used as a cutter, wire twister and as pliers
- Pliers are a spring loaded automatic return style
- Safety wire is .032" stainless steel and comes in a 1 lb. can
- Used in high vibration areas to keep bolts secure

BEP41040 Safety Wire Pliers  
BEP41045 Stainless Steel Safety Wire



**CRANKSHAFT SOCKET TOOL**

- Designed to rotate the engine during short block assembly with the balancer removed
- Accepts 1/2" drive ratchet or breaker bar

BEP41013 BB Chevy  
BEP41014 Buick, Olds, Pontiac, Ford  
BEP41015 SB Chevy, V6 Chevy, Pontiac 4-Cylinder



**PRO SERIES OIL PUMP PRIMER**

- Pressure bushing for upper valve train lubrication
- Fits SBC and BBC applications

BEP41053 Pro Series Oil Pump Primer



**TOP DEAD CENTER LOCATOR**

- Screws into the spark plug hole and positively stops the piston in order to find top dead center

BEP41052 Top Dead Center Locator, 14mm  
BEP41058 Top Dead Center Locator, 18mm



**ROD BOLT STRETCH GAUGE**

- Check rod bolt yield for correct rod bolt fastener pre-load
- Includes .001" increment dial indicator with a heavy duty adjustable fixture
- Fits rod bolts up to 2.750" long

BEP41062 Rod Bolt Stretch Gauge



**HIGH QUALITY PRODUCTS  
PRICED RIGHT!**

**ADJUSTABLE PISTON RING COMPRESSORS**

- Eliminates individual bore size ring compressors
- Made of aluminum with a hard coat anodizing. Tapered inner diameter compresses the piston rings for a smooth installation

BEP41025 4.000"-4.090" Diameter Bore  
BEP41026 4.125"-4.205" Diameter Bore  
BEP41027 4.205"-4.310" Diameter Bore



**STORAGE BAGS**

- Plastic shipping and storage bags keep your engine block, crankshaft or cylinder heads clean and sealed when shipping or storing your newly machined parts
- 5/pkg

BEP43090 Engine Block Bags  
BEP43095 Crankshaft/Cylinder Head Bags





**PERFORMANCE HEAD GASKETS**

- Wire ring head gaskets in various bore sizes, thicknesses and materials to meet any need
- Designed to be relied on by the professional racer as well as the Sunday cruiser when it comes to sealing combustion pressure, coolant and oil under all conditions
- Sold as packs of 10

SB Chevy

BEP49100	4.166" Bore, .041" (1003)
BEP49105	4.190" Bore, .041" (1004)
BEP49110	4.166" Bore, .039" (1010)
BEP49115	4.200" Bore, .041" (1034)
Chevy427/454/502 (not GenV/VI)	
BEP49130	4.540" Bore, .039" (1017-1)
Ford 260/289/302/351W	
BEP49150	4.100" Bore, .039" (1011-2)

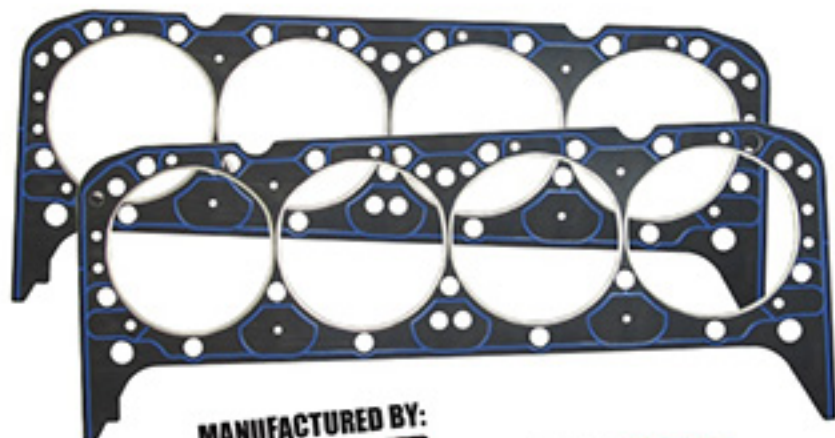

MANUFACTURED BY:

**FUEL PUMP GASKETS**

- Fits most SB Chevy applications
- Made by Fel-Pro!
- Sold in packs of 10

BEP49605	Fuel Pump Gasket, 10/pkg.
BEP49610	Fuel Pump Mounting Plate Gasket, 10/pkg.



**HIGH QUALITY PRODUCTS  
PRICED RIGHT!**

**BIG END™**  
PERFORMANCE PRODUCTS

**PERFORMANCE INTAKE GASKETS**

- Constructed of selected materials which offer excellent sealing performance while allowing the user to easily trim and match modified port shapes
- Utilize a synthetic rubber bead where applicable for superior sealing around intake and coolant ports
- Most intake manifold gasket sets include blue cork/rubber end strips with adhesive backing
- Sold in packs of 10

SB Chevy

BEP49200	Port: 1.28" x 2.09", .060" (1205)
BEP49205	Port: 1.31" x 2.21", .060" (1206)
BB Chevy	
BEP49230	Port: 1.82" x 2.54", .060" (1275)

**PERFORMANCE EXHAUST GASKETS**

- Consist of high-density fiber attached to both sides of a perforated steel core
- These gaskets can even seal slightly warped surfaces and resist blowout/burnout from high-temp exhaust gas
- Nonstick coating allows motion without damage, which simplifies gasket removal for servicing
- Sold in packs of 10



SB Chevy

BEP49300	Square Vortec, Port Size 1.50" x 1.50" (1404)
BEP49305	Square, Port Size 1.55" x 1.55" (1405)

**VALVE COVER GASKETS**

- Silicone rubber with steel core gives added support and prevents gasket slippage and movement
- Sold in pairs

BEP49418	Blue, SB Chevy 55-86
BEP49438	Blue, BB Chevy 65-85
BEP49458	Black, SB Ford 260-289-302-351W
BEP49410	Black Centerbolt Gaskets 86-97 SB Chevy (Without Steel Core)

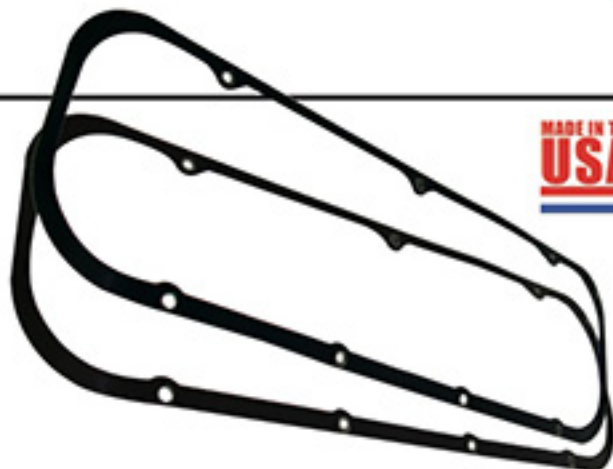

**MADE IN THE USA**

**MOLDED SILICONE VALVE COVER GASKETS**

- Features solid-steel core and high-tech molded silicone-rubber sealing material
- Great for engines running vac pumps
- Gaskets can be removed and reinstalled easily
- Stainless steel compression limiters prevent over-tightening

BEP49405	SBC 55-86 Perimeter Bolt Gasket .340" Thick with 0.250" Limiters
BEP49435	BBC Molded Silicone Valve Cover Gasket with Steel Core .137" Thick
BEP49455	SBF Windsor Molded Valve Cover Gasket with Steel Core .200" Thick

**PERFORMANCE VALVE COVER GASKETS**

- Cork-Lam is used in applications where high vacuum or blowout conditions can be a problem
- Cork-Lam uses a metal core with cork-rubber material chemically bonded to it on both sides
- Allows for a thicker than normal gasket with exceptionally good torque retention and also allows for more clearance between the valve cover and valvetrain
- Sold in packs of 10

BEP49400	SB Chevy, 5/16" (1604)
BEP49430	BB Chevy, 5/16" (1630)

**TIMING COVER GASKETS**

- Designed to deliver a perfect seal on every engine
- Sold in packs of 10

BEP49505	SB Chevy
BEP49535	BB Chevy

**WATER PUMP GASKETS**

- Designed to deliver a perfect seal on every engine
- Sold in packs of 10

BEP49500	SB Chevy Water Pump Gaskets
BEP49530	BB Chevy Water Pump Gaskets



**BULK PACK 10 GASKETS**  
**MADE IN THE USA**

**BULK PACK 10 GASKETS**  
**MADE IN THE USA**

**DISTRIBUTOR MOUNTING GASKET**

- Designed to deliver a perfect seal on every engine
- Sold in packs of 10

BEP49600	Distributor Gaskets
----------	---------------------



**BULK PACK 10 GASKETS**  
**MADE IN THE USA**

**WATER OUTLET GASKET**

- Designed to deliver a perfect seal on every engine
- Sold in packs of 10

BEP49615	Water Outlet Gaskets
----------	----------------------



**BULK PACK 10 GASKETS**  
**MADE IN THE USA**

**BULK PACK 10 GASKETS**  
**MADE IN THE USA**



### PRO-FLOW RACING RADIATORS

- 100% aluminum welded construction, for the budget racer
- Cross flow design with a dual 1" tube and 2-1/4" thick core
- Stamped and furnace welded aluminum side tanks with 1-1/2" upper and 1-3/4" lower beaded radiator hose push-on tube
- 3/4" solid upper and lower channel mounting. No gaskets, seals or epoxy to leak! Must use BEP60552 for over-flow hookup

Part #	Overall Size	Core Size
Ford/Mopar		
1-1/2" Upper P.S. Outlet, 1-3/4" Lower D.S. Inlet		
BEP60570	22" x 19"	18" x 18-3/4"
BEP60571	26" x 19"	22-3/8" x 18-3/4"
BEP60572	28" x 19"	24-3/8" x 18-3/4"
BEP60573	31" x 19"	27-1/2" x 18-3/4"
BEP60528	28" x 16"	22-3/8" x 15-3/4"
GM 1-1/2" Upper D.S. Outlet, 1-3/4" Lower P.S. Inlet		
BEP60574	22" x 19"	18" x 18-3/4"
BEP60575	26" x 19"	22-3/8" x 18-3/4"
BEP60576	28" x 19"	24-3/8" x 18-3/4"
BEP60577	31" x 19"	27-1/2" x 18-3/4"
BEP60526	28" x 16"	22-3/8" x 15-3/4"

### RACING RADIATOR WITH OIL COOLER

- Features internal aluminum oil cooler
- 1/2" female NPT fitting, accepts any 1/2" NPT adapter
- 100% aluminum furnace-brazed welded construction
- 3/4" solid upper and lower channel for easy mounting
- No gaskets, seals or epoxy to leak
- Must use BEP60552 fitting for overflow hookup

Part#	Overall Size	Core Size
GM 1-1/2" Upper D.S., 1-3/4" Lower P.S.		
BEP60522	28" x 19" x 3"	24-3/8" x 18-3/4" x 2-1/4"
BEP60524	31" x 19" x 3"	27-1/2" x 18-3/4" x 2-1/4"

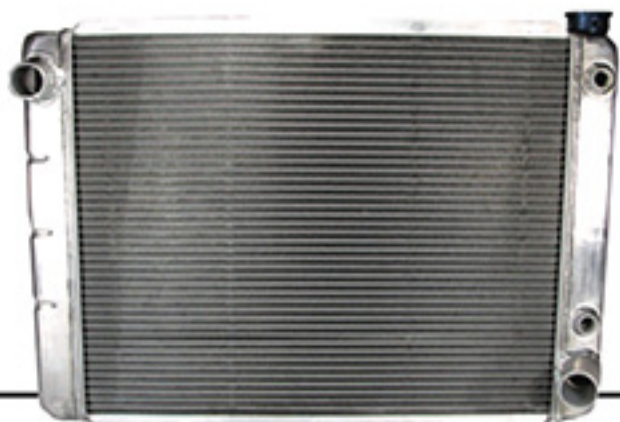

### ALUMINUM RADIATOR FAN SHROUDS

- Fits our 19" radiators exactly, with a close, trim fit on others
- 2.63" high with a 3" trimmable collar
- Choose off-center, side to side and above radiator fan positioning
- Shroud is fully-formed from .060 aircraft aluminum
- Adjustable collar, adjusts from 15-20" fan diameters
- Includes all necessary hardware and instructions

BEP60564	22" Radiator - Size: 19-5/16" x 16-3/4"
BEP60565	26" Radiator - Size: 19-5/16" x 20-1/2"
BEP60566	28" Radiator - Size: 19-5/16" x 22"
BEP60567	31" Radiator - Size: 19-5/16" x 25-3/4"

### OVERFLOW OUTLET FITTING

- Made of aluminum and screws into the radiator cap neck
- 5/16" hose, 1/8" male NPT

BEP60552 Overflow Outlet Fitting



### POLISHED ALUMINUM RADIATOR CAP

- Polished aluminum hexagon shaped cap
- Billet aluminum cover over a premium 16-lb. radiator cap

BEP60585 Polished Hexagon Radiator Cap



**HIGH QUALITY, BIG VALUE**  
**BIG END**<sup>TM</sup>  
**PERFORMANCE PRODUCTS**

**MADE IN THE**  
**USA**

**ELECTRIC FANS**

- Replaces belt-driven fan or for use as an auxiliary cooling fan
- Mounts in front or behind radiator; reversible: pusher or puller
- Fan only; no controls
- 8-10 AMP draw



- BEP60018** 10" Dia., RPM 2,100 Air Flow 1,000 CFM, Mounting Size 11-3/4" x 10-1/2" x 2-1/2"; AMP Draw: 6.5
- BEP60020** 12" Dia., RPM 2,340 Air Flow 1,200 CFM, Mounting Size 13-3/4" x 12-1/2" x 3-1/4"; AMP Draw: 9.0
- BEP60022** 14" Dia., RPM 2,220 Air Flow 1,650 CFM, Mounting Size 15-1/4" x 14-1/2" x 3-1/4"; AMP Draw: 9.5
- BEP60025** 16" Dia., RPM 1,860 Air Flow 2,100 CFM, Mounting Size 17" x 16" x 3-1/4"; AMP Draw: 11.0

**S-BLADE FANS**

- S-blades are engineered for a quiet, efficient airflow
- Reinforced nylon shroud withstands high temps
- Fan only; no controls
- Can save up to 17 HP and 20 ft. lbs. of torque when used as a primary cooling fan



- BEP60080** 12" Dia., RPM 2,245, Air Flow 920 CFM, Mounting Size 12-5/8" x 11-3/4" x 2-5/8"; AMP Draw: 8.0
- BEP60085** 16" Dia., RPM 2,190, Air Flow 2,010 CFM, Mounting Size 16-5/8" x 15-3/4" x 4"; AMP Draw: 13.0

**FLEX FANS**

- Designed for use in limited clearance applications
- Low pitch reduces drag on engine for high performance and improved gas mileage
- 8,000 RPM rating
- Universal bolt pattern, 5/8" pilot hole
- Stainless blades with gray steel center



- BEP60000** Flex Fan 17" Dia.
- BEP60005** Flex Fan 18" Dia.



**MADE IN USA**

**SEMI-FLEX FANS**

- Designed for use on high performance vehicles, or for towing
- Large blade allows more airflow through radiator
- 8,000 RPM rating
- Flexible stainless steel blades with gray center hub
- For max cooling, fan shroud is recommended
- Standard rotation, 5/8" pilot hole

- BEP60010** Semi-Flex Fan 17" Dia.
- BEP60015** Semi-Flex Fan 18" Dia.

**SERPENTINE FANS**

- Reverse rotation, serpentine belt applications
- Designed for use on high performance vehicles, or for towing
- 8,000 RPM rating
- Flexible stainless steel blades with gray center hub
- Fan shroud is recommended for maximum cooling
- Universal bolt pattern, 5/8" pilot hole



- BEP60011** Reverse Rotation Fan 17" Dia.
- BEP60016** Reverse Rotation Fan 18" Dia.

**MADE IN USA**

**ALUMINUM FLANGE MOUNTING KIT**

- Features strong lightweight aluminum brackets with slotted mounting holes
- Sold in pairs

- BEP60551** Radiator Flange Mounting Kit

**RUBBER MOUNTING PADS**

- Isolate from vibration damage
- GM or universal style
- Cut-to-fit application, sold in pairs



- BEP60555** Mounting Pads, GM Style
- BEP60556** Mounting Pads, Universal

**MOLDED NYLON FANS**

- Lightweight nylon construction relieves stress from the water pump and bearings, which provides maximum cooling
- Ideal for race and performance when cost or weight is a concern
- Universal bolt pattern, 5/8" pilot hole
- 8,000 RPM rating



- BEP60040** 14" Dia.
- BEP60041** 15" Dia.
- BEP60042** 16" Dia.
- BEP60043** 17" Dia.
- BEP60044** 18" Dia.

**STEEL MOUNTING KIT**

- BEP60550** Steel Radiator Mounting Kit

**BILLET FILLER NECK**

- Replaces damaged filler neck on aluminum radiators
- Heavy duty billet aluminum

- BEP60557** Billet Filler Neck

**ALUMINUM INLET AND OUTLET KIT**

- Includes 1-3/4" and 1-1/2" beaded hose fittings

- BEP60560** Radiator Inlet and Outlet Kit



**TRANSMISSION OIL COOLERS**

- Extends transmission life by cooling trans fluid
- Tests show a 20°F drop in transmission fluid temperature
- With hardware, hose and fittings
- 3/8" hose barb

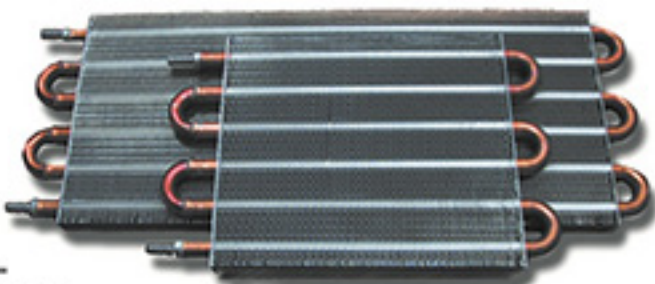
**MADE IN THE USA****Trans Cooler Barbed Hose Fittings**

- BEP60050** Standard Duty, 12,000 GVW, 5" x 13" x 3/4"  
**BEP60055** Added Cooling, 16,000 GVW, 7-1/2" x 13" x 3/4"  
**BEP60057** Standard Towing, 18,000 GVW, 7-1/2" x 15-1/4" x 3/4"  
**BEP60060** Heavy Towing, 20,000 GVW, 10" x 15-1/4" x 3/4"  
**BEP60062** Extra Heavy Duty, 26,000 GVW, 12-5/8" x 16-5/8" x 3/4"

**Race Cooler -6 AN Fittings**

- BEP60075** 16,000 GVW, 7-5/8" x 13-1/2" x 3/4"  
**BEP60077** 18,000 GVW, 7-5/8" x 17-1/2" x 3/4"

**OIL COOLER REMOUNT KIT**

- Includes 4 nylon bolts, washers, nuts and rubber spacers

**BEP60070** Oil Cooler Remount Kit**ALUMINUM SWIVEL WATER OUTLETS**

- 360° swivel rotation, extra thick base
- Available in straight, 40° and 90° hose angle
- Polished aluminum fits Chevrolet and other applications
- O-ring seal and hardware included

- BEP60120** 40° Aluminum Water Outlet  
**BEP60121** Straight Aluminum Water Outlet  
**BEP60122** 90° Aluminum Water Outlet  
**BEP60126** Replacement O-Ring for Swivel Aluminum Water Necks

**ALUMINUM WATER PUMP**

- Made of an aluminum alloy for weight savings of 30 to 50% over cast iron
- Heavy duty bearing and seals
- Some aftermarket pulleys may require shims (not included)
- 8-hole universal hub, 5/8" hub pilot
- Gaskets included



- BEP60300** 55-95 SB Chevy Short Pump Std. Rotation  
**BEP60305** 55-95 SB Chevy Long Pump Std. Rotation

**REMOTE ELECTRIC WATER PUMP**

- Aluminum housing, billet base, 20 GPM flow rate, billet impeller
- Anodized for corrosion protection
- Includes necessary hardware
- 12 AN O-ring inlet and outlet fittings (sold separately)

**BEP60350** Black Pump, Inline Remote Mount**MADE IN THE USA****ALUMINUM HEXAGON OVERFLOW TANK**

- Complete with chrome barbed inlet fitting, drain valve and mounting brackets
- 8" tall by 3" diameter
- Holds 20 oz. of coolant

**BEP60425** Aluminum Overflow Tank**STAINLESS STEEL RADIATOR OVERFLOW BOTTLE**

- 8" x 3" bottle stores 20 oz. of excess coolant
- 1/4" inlet and outlet barbed fitting accepts all rubber and plastic tubing
- Chrome fittings and drain valve
- Includes stainless steel hardware

**BEP60420** Stainless Steel Radiator Overflow Bottle**HD ELECTRIC FAN PIGTAIL**

- Simplifies the installation of most Big End electric fans

**BEP54100** HD Electric Fan Pigtail, 2-Wire Lead, 12 Ga.

**READY-TO-RUN DISTRIBUTORS**

- Provides reliable spark throughout the RPM range, delivering the performance you need
- Precision CNC-machined lightweight aluminum housing for strength and stability
- High-output magnetic trigger
- Adjustable vacuum advance
- Polished steel shafts with sealed ball bearings

BEP55004	SB Ford
BEP55005	Ford FE
BEP55006	BB Ford
BEP55007	Pontiac V8
BEP55008	Chevy V8 (ex. tall deck)

BEP55087	Replacement Cap and Rotor Kit
BEP55088	Chevy Replacement Module
BEP55089	Ford/Pontiac Replacement Module

**BILLET STREET/STRIP DISTRIBUTORS**

- Perfect for race engines
- Small cap and bowl design fits where a larger and bulkier distributor will not
- Precision 6061-T6 CNC-machined lightweight aluminum housing for strength and stability
- Cap and rotor are molded in high quality 30% glass-filled polyester
- High output magnetic pickup and large paddle wheel reluctor provide a strong trigger signal at high RPMs
- These distributors require the use of an ignition control box

BEP55002	Chevrolet, Mechanical Adv.
BEP55003	Chevrolet, Vacuum Adv.

**COMPETITION CHEVY HEI DISTRIBUTOR**

- For Chevrolet V8 engines 262-400 and 396-502 (ex. tall block)
- 100% new from cap to gear in a cast aluminum housing
- 50,000 KV HEI coil provides higher output for higher RPM with quicker response
- High performance mechanical advance
- Hardened steel distributor gear, .491" shaft
- RPM range up to 7,000 RPM without misfire

BEP55001	Competition Chevy HEI Distributor, Red Cap
----------	--

**REPLACEMENT FACTORY HEI PIGTAIL HARNESS**

BEP54105	GM HEI Pigtail Harness
BEP54106	HEI Tachometer Hookup

**BRONZE DISTRIBUTOR GEAR**

BEP42050	Chevy .500 Shaft
BEP42051	Chevy .491 Stock HEI

**ADJUSTABLE VACUUM ADVANCE**

- Adjustable Vacuum Advance for HEI replaces your OE non-adjustable unit
- Allows you to change the amount of ignition vacuum advance for maximum performance while preventing detonation
- Increases throttle response and horsepower while improving performance and fuel economy



BEP55091	GM HEI Adjustable Vacuum Advance
----------	----------------------------------

**BILLET DISTRIBUTOR HOLD DOWNS**

- Superior clamping
- CNC-machined from 6061-T6 aluminum
- Anodized for long-lasting beauty
- Fits all SB/BB/90° V6 Chevy engines
- Includes stainless steel stud

BEP55100	Distributor Hold Down, Clear
BEP55101	Distributor Hold Down, Blue
BEP55102	Distributor Hold Down, Red
BEP55103	Distributor Hold Down, Black

**MADE IN THE  
USA**

**HEI VACUUM ADVANCE LOCKOUT**

- Allows you to lock out the vacuum advance on GM HEI distributors by removing the vacuum advance and replacing it with this



BEP55092	GM Vacuum Advance Lockout
----------	---------------------------

**RACING DISTRIBUTOR CLAMP**

- Large rugged clamp reduces the chance of timing changes because of a loose distributor
- Fits all SB Chevy, BB Chevy and 90° V6 engines



**BEP55015** Racing Distributor Clamp

**HIGH OUTPUT IGNITION COIL**

- This coil is designed to work with our ready-to-run distributors
- It features heavy gauge windings that are engineered to ensure maximum power at higher RPM levels, and its heavy duty housing with epoxy encapsulation resists shock and vibration, and provides excellent conductivity



**BEP55043** High Output Ignition Coil

**HEI H.O. TUNE-UP KIT**

- Kit includes everything you need to rebuild your HEI distributor, including a high output 50K volt coil, new cap and rotor with wire retainer, coil dust cover, low saturation ignition coil, adjustable vacuum advance unit, HEI bushing, wiring harness and capacitor, and a high performance advance spring and weight kit



**BEP55025** HEI H.O. Tune-Up Kit

**PUSH BUTTON SWITCH WITH CORD**

- For use with trans brake, line lock or nitrous
- Coiled cord for easy mounting

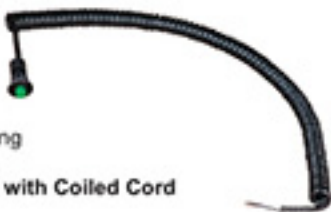

**BEP52015** Micro Switch with Coiled Cord

**SPARK PLUG WIRE DIVIDER KIT**

- Pro style wire separator kit fits wires from 8mm to 9mm
- Each kit includes 2 plastic 2-hole separators, 2 plastic 3-hole separators and 2 plastic 4-hole separators



**BEP55110** Spark Plug Wire Separator Kit

**UNIVERSAL IGNITION COIL**

- 12V heavy duty, 40,000V coil
- Oil filled canister keeps the coil cool and reliable
- Includes chrome bracket



**BEP55044** Chrome Coil with Bracket

**GM HEI ADVANCE CURVE KIT**

- Recurve a GM HEI for full spark advance and high RPM
- Contains weights, centerplate, 3 sets of springs, 4 nylon bushings

**BEP55050** GM HEI Advance Curve Kit 74-79

**BRAIDED FLEXWRAP**

- Lightweight, soft to quiet vibrations, abrasion resistant and flame retardant
- Flexwrap retains its shape and rigidity throughout temperatures from -94°F to 257°F



	Size	Length
<b>BEP56000</b>	1/8"	25'
<b>BEP56001</b>	1/4"	20'
<b>BEP56002</b>	3/8"	12'
<b>BEP56003</b>	1/2"	10'
<b>BEP56004</b>	3/4"	8'
<b>BEP56005</b>	1"	8'
<b>BEP56006</b>	1-1/2"	4'

**TOGGLE SWITCHES**

- Heavy duty 25A rating
- Screw terminals
- On/off single throw, used for fuel pumps, electric fans, etc



**BEP52000** Short Handle 11/16" (ea.)  
**BEP52005** Long Handle 1-1/2" (ea.)

**AIRCRAFT STYLE SWITCH COVER**

- Stops accidental switch on or off
- Fits most standard toggle switches
- Switch sold separately

**BEP52050** Aircraft Style Cover



**WEATHER PACK STARTER KIT**

- Weather pack starter kits include 101 pieces and have enough components to make 13 connections
- Starter kit includes enough pieces to do (2) 4-pin, (3) 2-pin, (4) 1-pin and (4) 3-pin connectors
- Includes 80 terminals, 50 seals and 26 housings

BEP54040 Weatherpack Starter Kit

**WEATHER PACK CONNECTORS**

- The unique design of the weather pack connector provides reliable connections that are not affected by water, oil, gasoline, dirt, vibration or temperature
- Connector locks together and provides each terminal with its own barrel, which leaves no chance of shorting
- Each terminal has silicone seals with multiple sealing ribs to prevent contaminants from entering through the wire or nylon housing
- Connectors, terminals, seals and installation tools sold separately

BEP54000 2-Pin Weather Pac Connector, 5/pkg.  
 BEP54001 3-Pin Weather Pac Connector, 5/pkg.  
 BEP54002 4-Pin Weather Pac Connector, 5/pkg.  
 BEP54003 6-Pin Weather Pac Connector, 5/pkg.

BEP54020 18-20-Gauge Wire Terminal and Seals, 10/pkg.  
 BEP54021 14-16-Gauge Wire Terminal and Seals, 10/pkg.  
 BEP54022 12-Gauge Wire Terminal and Seals, 10/pkg.  
 BEP54030 Extractor and Installation Tool  
 BEP54031 Crimping Tool

**UNIVERSAL 40-AMP RELAYS**

- Universal applications, electric fans, fuel pumps, etc.
- 5-pin relay, 40A relay



BEP52010 40A Relay w/ Harness  
 BEP52008 Universal 40A Relay, Single Pole

**STARTER SOLENOID RELOCATION KIT**

- Mounts a new starter solenoid away from exhaust heat
- Includes a Ford style remote starter solenoid, terminal ends, all necessary wiring and instructions

BEP52021 Starter Solenoid Relocation Kit

**CHEVY DENSO STARTER**

- Fits all small blocks, big blocks and 90° V6 engines
- Dual pattern mounting for 153 and 168 tooth flywheels
- Delivers 180 ft. lbs. of torque
- 4.4:1 gear reduction
- Mounting bolts included

BEP50004 Chevy Denso Starter 153/168 Tooth Flywheel

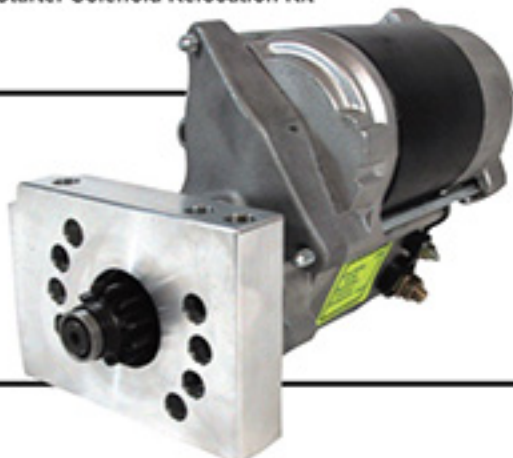
**NEW CHEVY PRO MINI STARTER**

- 100% new components
- Higher torque power for up to 18:1 compression
- 1" longer armature, 2.68 horsepower with 2.0 KW motor and 3.75:1 gear reduction
- Fits all V8 and V6 Chevy engines with 153 and 168 tooth flywheel
- Works with kick-out oil pan
- 3 clock mounting positions; comes with mounting bolts and shims

BEP50002 New Chevy Pro Mini Starter, Hitachi Style

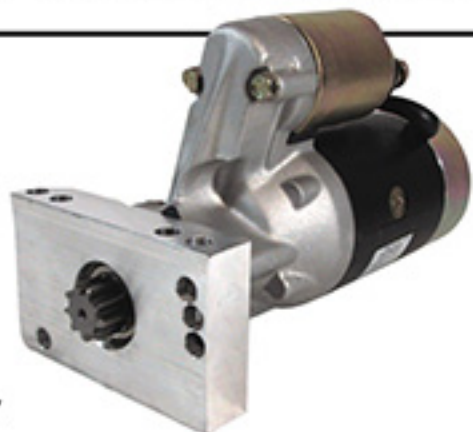



**CHEVY PERMANENT MAGNET STARTER**

- Utilizes reliable permanent magnetic coaxial tech
- 1.4KW motor, 6:1 ratio
- 30% lighter than a typical mini-starter its size
- Fits all small blocks, big blocks and 90° V6 engines
- 360° mounting positions for max installation clearance
- Strong enough to turn 13:1 compression engines
- Weighs 7.5 lbs

BEP50064 Permanent Magnet Chevy Starter

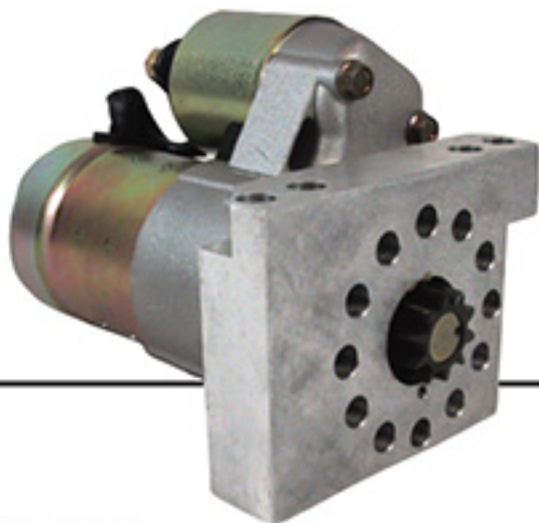
**CHEVY MINI STARTER**

- Starter fits all V8 and V6 Chevy engines with 153-168 tooth flywheels
- Works with kick-out oil pan, 3.7:1 gear reduction, delivers 165 ft. lbs. of torque to spin engines up to 11:1 compression
- 3 clock mounting positions, mounting bolts included
- Weight 11 lbs.

BEP50000 Rebuilt Chevy Mini Starter, Hitachi Style

**CHROME MINI STARTER**

- Chrome mini starter has a 1.9 HP motor, 90A draw, 3.7:1 gear ratio, full ball bearings and the power to crank over engines with up to 12.1 compression
- Fits straight across mounting
- Works on both 153 and 168 tooth flywheels

BEP50003 Chrome Chevy Mini Starter

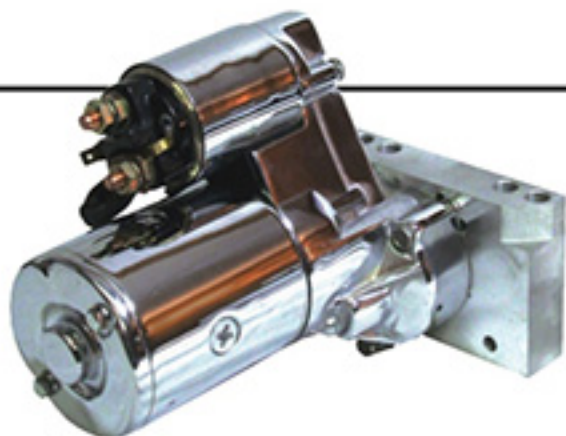
**PONTIAC AND OLDSMOBILE DENSO STARTER**

- Fits all 326-455 V8 Pontiac and all 350-455 Olds engines
- Delivers 180 ft. lbs. of torque
- 4.4:1 gear ratio

BEP50009 Pontiac and Oldsmobile V8 Denso Starter

**REPLACEMENT STARTER BOLT SET**

- Includes bolts and shims

BEP50020 Starter Bolt Kit

**PUSH BUTTON STARTER SWITCH**

- 35A, 12V

BEP50025 Push Button Starter Switch



**BIG BLOCK FORD DENSO STARTER**

- Fits all 351C, 351M, 400, 429 and 460 engines
- Delivers 180 ft. lbs. of torque
- 4.4:1 gear reduction ratio

**BEP50018** Big Block Ford 351-460  
Denso Starter

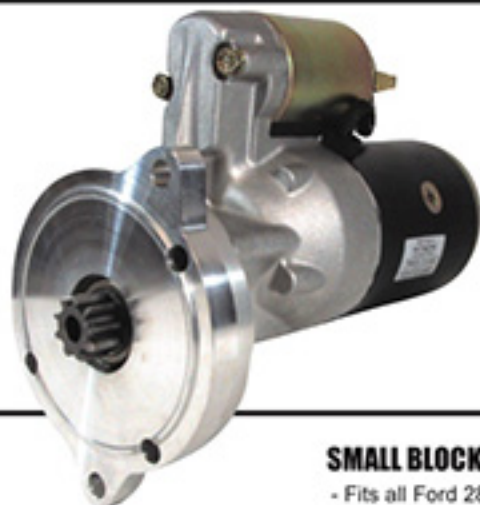
**NEW FORD MINI STARTER**

- 100% new components.
- Higher torque power for up to 14:1 compression
- 1.4 KW motor provides 40-50% more torque than O.E.
- Fits all 221, 289, 302 and 351W (and 300 L6 engines with SA738 starter)
- Works with kick-out oil pan, more clearance for headers
- 3.7:1 gear reduction

**BEP50060** Ford Mini Starter, Automatic Transmission

**SMALL BLOCK FORD DENSO STARTER**

- Fits all Ford 289, 302 and 351W engines
- Delivers 180 ft. lbs. of torque
- 4.4:1 gear reduction ratio
- Designed to fit all automatics and 5-speed transmissions

**BEP50017** Small Block Ford 289-351W  
Denso Starter

**CHRYSLER DENSO STARTER**

- Fits all Chrysler small and big block V8 engines with automatic and manual transmissions
- Delivers 180 ft. lbs. of torque
- 4.4:1 gear reduction ratio
- No clock positioning

**BEP50013** Mopar Denso Starter

**CHRYSLER MINI STARTER**

- Weight: 10.5 lbs., amp draw: 80 to 90
- Solenoid housings sealed with O-rings for added protection
- Full ball bearing construction for lasting performance
- Billet aluminum adapters with 4 adjustable mounting positions

**BEP50023** SB/BB Chrysler Mini Starter

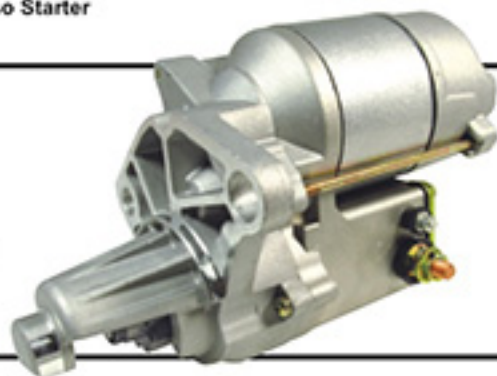

**HIGH QUALITY PRODUCTS  
PRICED RIGHT!**

**BIG END™**  
PERFORMANCE PRODUCTS

**MASTER POWER DISCONNECT SWITCH**

- Required in all categories of racing to cut the main power supply between the battery and the electrical system
- NHRA and IHRA approved
- A quick-twist/non-slip lever provides a fast power cut-off. Rated at 175A continuous; 1,000A intermittent
- Fits panels up to 3/16" thick



- BEP50030** Master Power Disconnect Switch, Single Pole (Battery Only)
- BEP50031** Master Power Disconnect Switch for Vehicle with an Alternator Charging System, Double Pole

**ON-OFF FACE PLATE**

- BEP50035** On-Off Face Plate

**CHROME GM ALTERNATORS**

- Chrome plated GM Delco-Remy, new or rebuilt alternators
- 1 or 3 wire hookup
- 100% new components
- Built-in voltage regulator



- BEP50051** 65A Alternator
- BEP50050** 100A Alternator
- BEP50055** 140A Alternator

**BOLT-ON BATTERY BOX**

- Die formed steel; lightweight yet strong
- Variety of mounting holes
- Includes pivoting hold down bolts, lock nuts and aluminum hold down strap
- Dimensions are 11" x 7" inside



- BEP58110** Adjustable Tray

**BATTERY CABLE END DISCONNECT SWITCH**

- 100A rated, for 12 or 24V systems



- BEP50044** Cable End Disconnect Switch

**THRU-PANEL BATTERY CONNECTOR**

- Can be used to provide a solid connection through any panel
- 1-1/4" diameter hole, sold each



- BEP50045** Thru-Panel Battery Connector

**REMOTE BATTERY JUMPER TERMINALS**

- Allows battery to be placed anywhere in the vehicle
- Sold separately



- BEP50040** Red (Positive)
- BEP50041** Black (Negative)

**GM ALTERNATOR PIGTAIL ASSEMBLY**

- Clips on the alternator terminal just like stock and will NOT vibrate off
- Will allow you to use 1-wire alternators just like stock
- Works with GM 10SI and 12SI series alternators



- BEP54110** GM Alternator Pigtail Assembly

**XHD MASTER DISCONNECT SWITCH**

- This switch is compatible with both 12V and 16V systems and is rated at 300A continuous and 2000A momentary
- Switch requires a 3/4" mounting hole and has 1/2" terminals
- Faceplate available separately



- BEP50032** XHD Master Disconnect Switch
- BEP50036** Faceplate for XHD Switch

**REMOTE-MOUNT ALUMINUM BATTERY BOX KIT**

- Move your battery to the trunk for better weight transfer
- Kit comes complete with battery box, hold downs and battery cable
- 23" ground cable, 14.66" positive
- 2 gauge wire



- BEP58100** Aluminum Battery Box Kit

**ELECTRICAL QUICK CONNECTS**

- Kits include 2 genderless housings and 4 contact terminals
- Terminals can be crimped or soldered on



- BEP54200** Quick Connect 1/0 AWG, to 175A
- BEP54210** Quick Connect 6 AWG, to 50A

**STUD TYPE REMOTE BATTERY JUNCTION BLOCKS**

- Kits include one positive (red) and one negative (black) terminal block with either a 3/8" or 10-32 studs that allow for the connection of battery cables through a bulkhead



- BEP50071** Replacement 3/8" Junction Block, Negative (Black)
- BEP50072** Replacement 3/8" Junction Block, Positive (Red)
- BEP50075** 10-32 Junction Block Kit, 1 Positive, 1 Negative
- BEP50076** Replacement 10-32 Junction Block, Negative (Black)
- BEP50077** Replacement 10-32 Junction Block, Positive (Red)

**14" CHROME AIR CLEANER TOP**

- 14" muscle car style top
- Chrome plated steel

BEP70015 Air Cleaner Top 14"

**AIR CLEANER BASES**

- 14" diameter air cleaner base
- Chrome plated steel

BEP70011 7-5/16" Dominator Base  
 BEP70012 5-1/8" Offset Base

**HI-FLOW AIR CLEANER ASSEMBLIES**

- Fits 5-1/8" carb neck
- Washable and reusable 3" element
- Less restrictive than paper elements; filters small dirt particles
- Increases horsepower
- Stud with wing nut included
- Measurements shown; air cleaner mounting surface to top



BEP70510 Hi Flow Filter, Semi-Recessed, 3-1/2"  
 BEP70511 Hi Flow Filter, Recessed, 2-7/8"  
 BEP70512 Hi Flow Filter, Flat, 4-1/2"

**BIG FLOW AIR CLEANER ASSEMBLIES**

- Provides excellent filtration and big air flow
- Washable and reusable 3" element
- Less restrictive than paper elements; filters small dirt particles
- Fits 5-1/8" carb neck
- 14" top has black anodized accent ring, chrome steel base
- Stud with wing nut included
- Measurements shown; air cleaner mounting surface to top



BEP70500 Filter Assembly, Semi-Recessed, 3-3/4"  
 BEP70501 Filter Assembly, Recessed, 3"  
 BEP70502 Filter Assembly, Flat, 4-1/2"

**HIGH FLOW CLEANER ELEMENTS**

- 14" filter elements are washable and reusable

BEP70520 14" x 3"  
 BEP70522 14" x 4"

BEP70521 14" x 2"  
 BEP70526 14" x 5"

**BIG FLOW AIR CLEANER TOPS**

- Replaces 14" filter tops
- Washable and reusable
- Increases horsepower
- Pre-oiled, ready to go

BEP70515 Chrome Trim Ring  
 BEP70516 Black Trim Ring

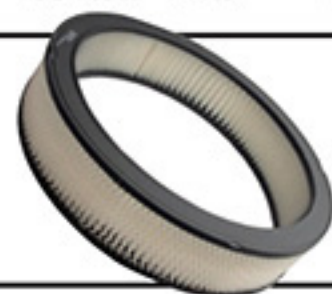
**REPLACEMENT FILTER ELEMENT**

- 14" x 3" air cleaner element replacement

BEP70010 14" x 3" Element

**AIR CLEANER STUDS**

- 1/4"-20 threaded offset stud with nuts
- Standard kit contains a 1/4"-20 x 6" stud and wing nut

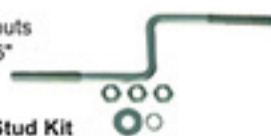

BEP70019 Offset Air Cleaner Stud Kit (for use w/ offset base)  
 BEP70017 Air Cleaner Stud and Wing Nut

**POLISHED ALUMINUM VALVE COVERS**

- Highly polished covers with a smooth finished top
- No breather holes
- Tall valve covers that clear aluminum rocker arms
- Mounting bolts included



BEP70030 Small Block Chevy, Tall 3-11/16"  
 BEP70032 SB Chevy Centerbolt 86-95, Tall 3-11/16"  
 BEP70035 Big Block Chevy, Tall 3-11/16"  
 BEP70038 SB Ford 289-351W 3-11/16" Tall

**POLISHED ALUMINUM VALVE COVERS WITH BREATHER HOLES**

- Highly polished covers with a smooth finished top
- Tall valve covers clear most aluminum rocker arms
- Mounting bolts included



BEP70034 SB Chevy 58-86 Covers 3-11/16" Tall  
 BEP70033 SB Chevy 87-97 Centerbolt Covers  
 BEP70039 SB Ford 62-85 289-302 Covers 3-11/16" Tall  
 BEP70041 BB Chevy 65-95 Covers 3-11/16" Tall



### FABRICATED ALUMINUM VALVE COVERS

- Fabricated lightweight 3003 H-14, .0125" thick aluminum
- TIG welded to maintain rail flatness and prevent leaks
- Clears most popular rocker arm combinations
- Fasteners included
- Now with 1/4" billet rails
- LS1 covers include oil cap and O-ring gasket

BEP70300	BB Chevy 3-1/2" Tall
BEP70320	SB Chevy 3-3/4" Tall
BEP70325	SB Chevy, Centerbolt
BEP70330	LS1 2-1/2" Tall w/ Coil Mounts
BEP70340	SB Ford 3-1/2" Tall
BEP70335	LS1 w/o Coil Mounts

### ALUMINUM OVAL TRACK VALVE COVERS

- Highly polished covers with a smooth-finished top
- Driver's side has (2) 1-3/8" OD tubes with baffles
- Passenger side is plain with no holes or tubes

BEP70036	SB Chevy 55-86 Covers 3-11/16"
BEP70037	SB Chevy 87-97 Centerbolt Covers 3-11/16"

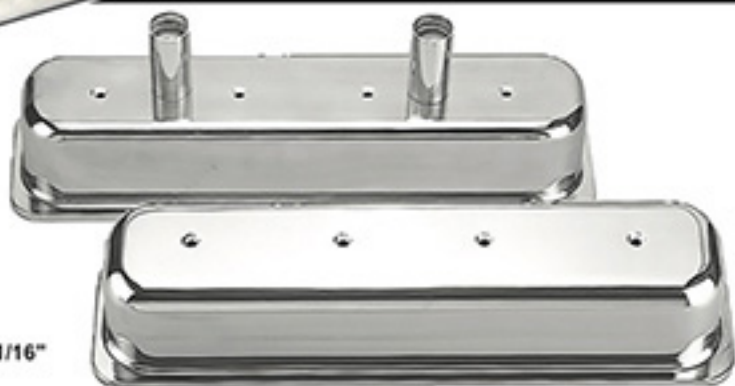

### STEEL OVAL TRACK VALVE COVERS

- Stamped steel, tall valve cover
- Raw steel or zinc plated
- 1-1/2" breather tubes



BEP47100	SB Chevy Raw Steel, 3-11/16"
BEP47101	SB Chevy Zinc Plated, 3-11/16"

### OIL FILLER CAP

- Chrome plated steel
- Push-in 1-1/4" hole
- No grommet required



BEP70140 Push-On Cap

### PUSH-IN CHROME BREATHERS

- Chrome plated steel
- For valve covers with 1-1/4" holes



BEP70135	Breather
BEP70133	Mopar Style w/Tube

### BIG FLOW BREATHERS

- Chrome plated steel top
- High flow open element design
- Available with or without shield



BEP70136	Push-In 1-1/4" Hole Open
BEP70137	Clamp-On 1-1/2" Tube Open, Rubber Base
BEP70138	Push-In 1-1/4" Hole Shielded
BEP70139	Clamp-On 1-1/2" Tube Shielded, Rubber Base
BEP70141	Clamp-On 1-3/8" Tube No Shield, Rubber Base
BEP70142	Clamp-On 1-3/8" Tube Shielded, Rubber Base

### BREATHER GROMMETS

- Fits into 1-1/4" dia. hole for 1" push-in breather
- Made of neoprene
- Sold in pairs



BEP70125	1-1/4" Hole Grommets (Pair)
BEP70124	3/4" to 1-1/4" OD Steel Valve Cover (PVC Type)
BEP70123	3/4" to 1-1/4" OD Aluminum Cover (PVC Type)

### BILLET BREATHER CLAMP

- Made from a billet 6061-T6 construction and outfitted with rubber grommet and stainless steel hardware
- Clear anodized. Will fit standard 1-1/4" valve covers as well as 1.22" to 1.25" push-in style



BEP70143 Billet Breather Clamp

**VALVE COVER SPREADER BARS**

- Chrome plated steel
- Gives support to valve cover rail to prevent oil leakage
- Distributes clamping pressure evenly for better sealing

BEP70190 SB Chevy Spreader Bars, 4/pkg.  
BEP70195 BB Chevy Spreader Bars, 7/pkg.

**BILLET BREATHER CLAMP**

- Mounts on valve cover
- Uses standard push-in breather
- Meets NHRA and IHRA requirements

BEP70134 Billet Breather Clamp

**BILLET VALVE COVER BAFFLE**

- Install a breather where a breather hole didn't exist
- Dual O-ring design works with most standard 1.22" push-in style breathers and requires a 1-3/8" diameter hole

BEP70144 Billet Baffle Kit

**VACUUM RESERVE CANISTER**

- All steel construction available in a black or chrome finish
- Comes complete with a one-way check valve, mounting bracket and mounting hardware

BEP48500 Canister, Black Steel  
BEP48505 Canister, Chrome Steel

**BILLET FILLER CAP KITS**

- Universal cap, can be used for multiple applications including valve cover oil fill, rear end filler, overflow tank cap, dry sump tank cap or whatever you can think of
- Made of CNC-machined 6061-T6 aluminum bar stock

BEP70350 Billet Cap with Aluminum Bung  
BEP70355 Billet Cap with Steel Bung  
BEP70351 Billet Cap Kit with Aluminum Bolt-On Bung

**CHROME VALVE COVER MINI-TABS**

- Valve cover hold down tabs distribute pressure more evenly for better sealing
- Universal set of 8

BEP70193 Chrome Valve Cover Mini-Tabs, 8/pkg.

**T-BAR WING NUTS**

- Extra long style 5-5/8" with a 1/4"-20 x 1-3/8" stud, 4 per package

BEP70150 Chrome, T-Bar Wing Nuts

**REPLACEMENT VALVE COVER BOLT KIT**

BEP70170 Bolt Kit 70035/41  
BEP70171 Bolt Kit 70300  
BEP70172 Bolt Kit 70032/33  
BEP70173 Bolt Kit 70320

**POWER STEERING PUMP PULLEYS**

BEP60295 Aluminum Pulley, V-Belt  
BEP60296 Chrome Pulley, V-Belt

**POWER STEERING PUMP**

- Dress up your engine with our chrome Saginaw-style power steering pump
- Fits most GM 66-76 Saginaw 5/8" keyed shaft style applications
- Shipped without a pulley so you can choose from either the standard V-belt or a serpentine style belt with a 5/8" keyed shaft
- Utilizes a 5/8"-18 fitting (not included)

BEP20555 Power Steering Pump, Chrome, Saginaw

**BILLET POWER STEERING PUMP MOUNT KIT**

- No more need to search for a power steering bracket at the local junkyard. Big End now offers the right solution to mount non-metric GM Saginaw style power steering pumps
- Available for both small block Chevy and big block Chevy engines and for both short and long water pumps
- Made from 6061-T6 aluminum and includes all stainless steel hardware

SB Chevy  
BEP50150 Bracket SBC Short Pump  
BEP50155 Bracket SBC Long Pump  
BB Chevy  
BEP50160 Bracket BBC Short Pump  
BEP50165 Bracket BBC Long Pump



POWER STEERING PUMP NOT INCLUDED

## BILLET ALUMINUM ALTERNATOR BRACKET KIT

- Here is your answer for mounting your alternator when using an aftermarket electric water pump
- Made from 6061-T6 aluminum and clear anodized, this mount will work with all aftermarket electric water pumps
- Bracket mounts in the mid-mount position on the passenger side of the engine and mounts a standard full size GM alternator
- Kit includes all stainless steel hardware and instructions



ALTERNATOR NOT INCLUDED

BEP50140 SBC w/ Electric Water Pump  
BEP50145 BBC w/ Electric Water Pump



## LOW-MOUNT ALTERNATOR BRACKET

- Fits all SB Chevy engines, left side mounting. Fits short water pump only
- Moves the alternator to the bottom left side of engine
- Chrome plated

BEP50131 Low Mount Bracket Kit

## COPPER EXHAUST HEADER GASKETS

- Gaskets are made from .043" dead-soft copper material, annealed for strength
- Embossed O-ring for tight leak-proof seal
- Will not shrink, deteriorate or blow out, even in severe duty applications
- Pair/package

Small Block Chevy 283-400

BEP82300 1.50" I.D. Round  
BEP82302 1.50" x 1.437" Lg. Sq.  
BEP82304 LT1 Chevy D-Port  
BEP82305 LS1 and GEN3 Engines

Big Block Chevy 396-502

BEP82320 1.75" x 1.75" Stock Square  
BEP82322 1.875" I.D. Round  
BEP82324 2.275" I.D. Round

Small Block Ford 289-302

BEP82340 Stock Port

Ford FE 352-428

BEP82350 Ford FE 352-390 Light Truck  
BEP82352 Ford FE 390-428 Stock Head

Ford Big Block 429-460

BEP82354 BB Ford Oval Ports

SB Block Chrysler 273-360

BEP82360 All 4bbl Head Through 1990

Big Block Chrysler 383-440

BEP82364 1.700" x 1.475" Max Wedge  
BEP82366 1.625" x 1.125" Stock Port

Oldsmobile 350-455

BEP82380 V8 Stock Head

Pontiac 326-455

BEP82386 D-Port Heads

AMC 360-401

BEP82390 Dog Leg Port



MADE IN THE USA

## COPPER COLLECTOR GASKETS

- Embossed copper collector gaskets
- O-ring design for a tight leak-proof seal
- Sold in pairs

MADE IN THE USA



BEP81001 2-1/2" Dia. Collector, Triangular  
BEP81006 3" Dia. Collector, Triangular  
BEP81011 3-1/2" Dia. Collector, Triangular

## ALUMINUM-SEAL COLLECTOR GASKETS

- Made of dead soft aluminum that conforms to create a leak-proof seal
- Will not burn or blow out
- Chrome plated nuts and bolts included



BEP80080 2-1/2" Dia. Collector Gaskets, 2/pkg.  
BEP80082 3" Dia. Collector Gaskets, 2/pkg.  
BEP80084 3-1/2" Dia. Collector Gaskets, 2/pkg.

## ELECTRIC EXHAUST CUTOUTS AND WIRING HARNESSES

- Bolt directly to a standard triangular 3-bolt exhaust flange for 3" pipe
- Control the exhaust flow path and go from stealthily quiet to wide-open in a matter of seconds



Exhaust Cutouts  
BEP82500 Single 3" Cutout

Wiring Kits  
BEP82501 Single Control Wiring Harness  
BEP82502 Dual Control Wiring Harness

## O<sub>2</sub> SENSOR BUNG AND PLUG

- Standard 18mm thread
- Stepped style bung for easy installation

BEP80060 O<sub>2</sub> Bung  
BEP80065 O<sub>2</sub> Plug



**HEADER TETHERS**

- Components are sold separately, allowing you to build a set that's specific to your needs!

## Primary Clamps (Packs of 2)

BEP82651	1-3/4"
BEP82652	1-7/8"
BEP82653	2"
BEP82654	2-1/8"
BEP82655	2-1/4"
BEP82656	2-1/2"

## Bracket

BEP82630

Aluminum Bracket

## Collector Clamps (Packs of 2)

BEP82679	3"
BEP82682	3-1/2"
BEP82684	4"
BEP82686	4-1/2"
BEP82688	5"

## Tether Cables (Packs of 2)

BEP82600	10" Cable
BEP82605	15" Cable
BEP82610	20" Cable

**SOUND AND HEAT BARRIER**

- Foil with butyl/rubber
- Choose silver or black
- Each package contains (9) 20" x 29" sheets (36 sq. ft.)
- Easily trimmed with scissors or a utility knife
- Adheres to sheet metal, plastic and fiberglass
- Can withstand temperatures from -30° to 400°F

BEP27500 Silver Barrier

BEP27510 Black Barrier

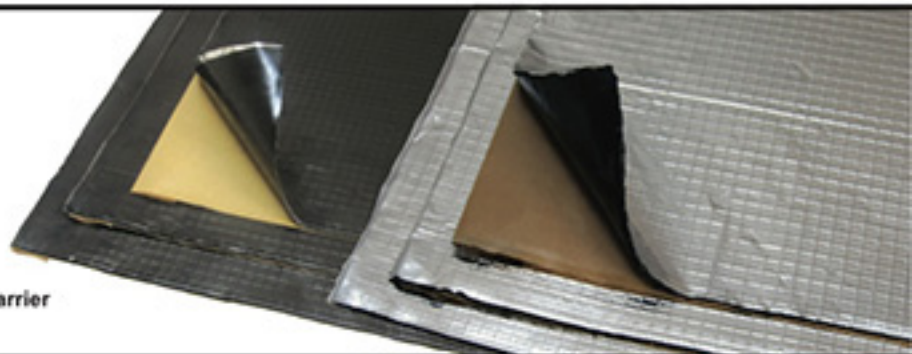
**EXHAUST HEADER WRAP**

- Reduce under-hood temps by up to 50%
- Contains header heat for added horsepower
- Protects up to 1500°F direct heat contact (up to 2000°F in short bursts)

BEP80100	Natural, 1" x 50'
BEP80105	Natural, 2" x 50'
BEP80106	Black, 1" x 50'
BEP80107	Black, 2" x 50'

**VOLCANO HEADER WRAP**

- Woven volcanic rock tape
- Withstands heat up to 1500°F
- 25% stronger and more protective than fiberglass wraps

BEP80103	Natural, 1" x 50'
BEP80104	Natural, 2" x 50'

**UNIVERSAL HEAT PROTECTION WRAP**

- Aluminized fiberglass heat barrier
- Protect starters, carbs, fuel pumps from extreme heat
- Protects up to 2000°F direct heat
- Easily fastens and trims
- 7" wide, 24" long



BEP80110 Universal Heat Protection Wrap

**STAINLESS STEEL EXHAUST WRAP TIES**

- Made from T-304 stainless steel
- Fireproof, withstands temps up to 2500°F
- Rust and corrosion resistant

BEP80108	8" Ties, 8/pkg.
BEP80109	14" Ties, 4/pkg.

**SPARK PLUG BOOT PROTECTORS**

- Protect spark plug boots from extreme header heat
- Protects up to 1,200°F
- Heat resistant construction



BEP80120 Plug Boot Protectors, Silver, 7.5" (8/pkg.)

**COLORLED SPARK PLUG BOOT PROTECTORS**

- Protects up to 1200°F
- Easy, slip-on installation can even be used on right-angle boots!
- Halogen free
- Resists gasoline and chemicals
- 7.5" plug boot
- 8 per pack

BEP80122	Black
BEP80124	Blue
BEP80126	Red





**A**

Accelerator Pump Diaphragms	16
Air Cleaner Elements	51
Air Cleaners	51
Alternator Brackets	54
Alternator Pigtaills	50
Alternators	50

**B**

Battery Boxes	50
Battery Connectors	50
Battery Junction Blocks	50
Battery Terminals, Remote	50
Bolts, Balancer	38
Bolts, Head	38
Bolts, Starter	48
Bolts, Timing Chain Cover Kits	36
Bolts, Valve Cover	53
Brackets and Tabs	25
Brackets, Fuel Pressure Regulator	14
Brackets, Nitrous	17
Brackets, Throttle Cable	14, 16
Braided Flexwrap	46
Brake Lines	6

**C**

Cables, Throttle	17
Cam Buttons	37
Camshaft Lock Plate Kits	37
Carburetor Jet Kits	18
Carburetor Line Kits	8
Carburetor Rebuild Kits	18
Carburetor Spacers	15
Carburetors, Adapter Kits	15
Carburetors, Cap	18
Cleco Pins	26
Crank Keys	38
Crankcase Evacuation Systems	37
Cross Pins	29

**D**

Dial-In Boards	23
Dial-In Markers	23
Distributor Clamps	46
Distributor Gears	45
Distributors	45
Dowel Pins	37
Drain Plugs, Magnetic	36
Driveshaft Safety Loops	32

**E**

EGR Block Off Plates	12
Electrical Connectors	50
Engine Cradles	39
Engine Lift Plates	39
Exhaust Cutouts and Wiring Harnesses	54
Exhaust Header Wraps	55
Exhaust Wrap Ties	55

**F**

Fan Pigtaills	44
Fastener Plates	24
Fasteners, Engine	38
Fittings, Adapter	8
Fittings, AN Adapter	10
Fittings, Brake Adapter	6
Fittings, Carburetor Extension	10
Fittings, Carburetor Inlet	10
Fittings, Coupler	9
Fittings, Expander and Reducer	9

**F, continued**

Fittings, Fuel Bowl	16
Fittings, Fuel Cell Bulkhead	9
Fittings, Fuel Pump	10
Fittings, Fuel Rail	10
Fittings, Gauge Adapter	10
Fittings, Hose End	2-5
Fittings, Nitrous	17
Fittings, Nitrous Distribution Block	17
Fittings, Pipe Plug	9
Fittings, Port Adapter	10
Fittings, Radiator Overflow	42
Fittings, Union	9
Fittings, Y	11
Flare Caps	8
Flexplates	28
Fuel Bowl Sight Plugs	18
Fuel Cells	19
Fuel Filters	12-13
Fuel Fragrances	33
Fuel Pressure Regulators	13-14
Fuel Pump Block Off Plates	12
Fuel Pump Mounting Plates	12
Fuel Pumps	12-13

**G**

Gaskets, Carburetor	15
Gaskets, Collector	54
Gaskets, Distributor	41
Gaskets, Exhaust	40, 54
Gaskets, Fuel Bowl	16
Gaskets, Fuel Pump	40
Gaskets, Head	40
Gaskets, Intake	40
Gaskets, Metering Block	16
Gaskets, Timing Cover	41
Gaskets, Valve Cover	41
Gaskets, Water Outlet	41
Gaskets, Water Pump	41
Gauge Panels	22
Gauges, Boost/Vacuum	20-22
Gauges, Engine Temperature	22
Gauges, Mounting Cup	22
Gauges, Nitrous Pressure	21
Gauges, Oil Pressure	20-22
Gauges, Oil Temperature	20-22
Gauges, Supply Line	22
Gauges, Tachometer	20-22
Gauges, Voltage	20-22
Gauges, Water Temp	20-22
Gear Sets	30-31
Guide Plates	38

**H**

Header Tethers	55
Heat Barriers	55
Heat Wrap	55
HEI Advance Curve Kits	46
HEI Tune-Up Kits	46
Hood Pin Kits	26
Hood Pin Lanyards	26
Hood Springs	26
Hose, Braided	5, 7
Hose, Flex-Fuel	4
Hose, Fuel	7, 11
Hose, Nitrous	19

**I**

Ignition Coils	46
Installation Kits, Complete	31
Intake Manifolds	19

**L**

Lifter Valley Vents	37
Line Clamps	32
Lubricants	33

**M**

Motor Mounts	37
Motor Plates	36

**O**

O <sup>2</sup> Plugs	54
O <sup>2</sup> Sensor Bungs	54
Oil Filler Caps	52
Oil Filter Adapters	36
Oil Pans	34-35
Oil Pump Driveshafts	36
Oil Pump Pickups	35
Oil Pump Primers	39
Oil Restrictors	36
One-Way Check Valves	11
Overflow Tanks	44

**P**

Panel Fastener Springs	24
Panel Fasteners	24
Pilot Bushings	38
Piston Ring Compressors	39
Port Plugs	8
Power Steering Pump Mounting Kits	53
Power Steering Pump Pulleys	53
Power Steering Pumps	53
Power Valve Plugs	16
Proportioning Valves	6
Pushrods, Fuel Pump	13

**R**

Racer Tape	23
Radiator Caps	42
Radiator Fan Shrouds	42
Radiator Fans	43
Radiator Filler Necks	43
Radiator Inlet/Outlet Kits	43
Radiator Mounting Kits	43
Radiators	42
Rear End Girdles	29
Relays	47
Residual Valves	6
Ring and Pinion Sets	30
Ring Gear Spacers	29
Rivets	26
Roll Bar Padding	23

**S**

Safety Wire	39
Screws, Wheel Rim	32
Scuff Plates	26
Seat Riser Brackets	23
Shear Plates	14
Sound and Heat Barriers	23
Spark Plug Boot Protectors	55
Spools	29
Starter Solenoids	47
Starters	47-49
Storage Bags	39
Studs, Air Cleaner	51

**S, continued**

Studs, Carburetor	18
Studs, Engine Accessory	38
Studs, Wheel	32
Switches, Aircraft Style	46
Switches, Power Disconnect	50
Switches, Push Button	46, 48
Switches, Toggle	46
Switches, WOT	17

**T**

Throttle Return Springs	16
Timing Chain Covers	36
Timing Pointers	37
Timing Tape	37
Tire Softeners	33

**Tools**

Cleco Pliers	26
Crankshaft Sockets	39
Drill Bits	26
Hose Assembly	3
Hose Press	4
Hose Pressure Test Kits	11
Nitrous Wrenches	17
Quarter-Turn Button Wrenches	24
Rod Bolt Stretch Gauges	39
Safety Wire Pliers	39
Tire Pressure Gauges	32
Top Dead Center Locator	39
Wrenches	3
Torque Converters	27
Trackbite	33
Transmission Oil Coolers	44
Tube Nuts	9
Tube Sleeves	9
Tubing Adapters	9
Tubing Clamps	11

**U**

Utility Jugs	19
--------------	----

**V**

Vacuum Advance Lockouts	45
Vacuum Advances	45
Vacuum Cap Kits	18
Vacuum Reserve Canisters	53
Vacuum Secondary Diaphragms	16
Vacuum Secondary Spring Kits	16
Valve Caps	32
Valve Covers	51-52
Valve Cover Baffles	53
Valve Cover Breather Clamps	52-53
Valve Cover Breather Grommets	52
Valve Cover Breathers	52
Valve Cover Spreader Bars	53
Valve Cover Tabs	53
Valve Stems	32

**W**

Washers	9, 16, 26
Water Outlets	44
Water Pumps	44
Weather Pack Kits	47
Welding Bungs	11
Wheel Spacers	32
Wheelie-Bar Chalk	33
Wheelie-Bar Wheels	32
Wing Nuts, T-Bar	53
Wire Separators	46

BEP12400	2	BEP41081	3	BEP21036	6	BEP13610	7	BEP14629	8
BEP12600	2	BEP13401	4	BEP21109	6	BEP13810	7	BEP14829	8
BEP12800	2	BEP13402	4	BEP21112	6	BEP13010	7	BEP14029	8
BEP12000	2	BEP13403	4	BEP21115	6	BEP13210	7	BEP14229	8
BEP12200	2	BEP13451	4	BEP21118	6	BEP13310	7	BEP12310	9
BEP12500	2	BEP13452	4	BEP21120	6	BEP13420	7	BEP12315	9
BEP14400	2	BEP13453	4	BEP21124	6	BEP13620	7	BEP12320	9
BEP14600	2	BEP13406	4	BEP21130	6	BEP13820	7	BEP12325	9
BEP14800	2	BEP13407	4	BEP21136	6	BEP13020	7	BEP14310	9
BEP14000	2	BEP13408	4	BEP21142	6	BEP13220	7	BEP14315	9
BEP14200	2	BEP13456	4	BEP21209	6	BEP13422	7	BEP14320	9
BEP14500	2	BEP13457	4	BEP21212	6	BEP13622	7	BEP14325	9
BEP12445	2	BEP13458	4	BEP21215	6	BEP13822	7	BEP12619	9
BEP12645	2	BEP13411	4	BEP21218	6	BEP13022	7	BEP12819	9
BEP12845	2	BEP13412	4	BEP21221	6	BEP13222	7	BEP12019	9
BEP12045	2	BEP13413	4	BEP21224	6	BEP13421	7	BEP14619	9
BEP12245	2	BEP13461	4	BEP21230	6	BEP13621	7	BEP14819	9
BEP12545	2	BEP13462	4	BEP21236	6	BEP13821	7	BEP14019	9
BEP14445	2	BEP13463	4	BEP21242	6	BEP13021	7	BEP12618	9
BEP14645	2	BEP41330	4	BEP21248	6	BEP13221	7	BEP12818	9
BEP14845	2	BEP13502	4	BEP21309	6	BEP12112	8	BEP12018	9
BEP14045	2	BEP13507	4	BEP21312	6	BEP12113	8	BEP14618	9
BEP14245	2	BEP13512	4	BEP21315	6	BEP12114	8	BEP14818	9
BEP14545	2	BEP13504	4	BEP21318	6	BEP12115	8	BEP14018	9
BEP12490	2	BEP13509	4	BEP21321	6	BEP12116	8	BEP12615	9
BEP12690	2	BEP13514	4	BEP21324	6	BEP12117	8	BEP12815	9
BEP12890	2	BEP23401	5	BEP21330	6	BEP12118	8	BEP12015	9
BEP12090	2	BEP23601	5	BEP21336	6	BEP12119	8	BEP12215	9
BEP12290	2	BEP23402	5	BEP21342	6	BEP14102	8	BEP14615	9
BEP12590	2	BEP23602	5	BEP20000	6	BEP14104	8	BEP14815	9
BEP14490	2	BEP23441	5	BEP20010	6	BEP14105	8	BEP14015	9
BEP14690	2	BEP23641	5	BEP20012	6	BEP14107	8	BEP14215	9
BEP14890	2	BEP23442	5	BEP22000	6	BEP14109	8	BEP12306	9
BEP14090	2	BEP23642	5	BEP22001	6	BEP14112	8	BEP12308	9
BEP14290	2	BEP23491	5	BEP22002	6	BEP14113	8	BEP12300	9
BEP14590	2	BEP23691	5	BEP22005	6	BEP14114	8	BEP12302	9
BEP12602	2	BEP23492	5	BEP22020	6	BEP14115	8	BEP14306	9
BEP12802	2	BEP23692	5	BEP22021	6	BEP14116	8	BEP14308	9
BEP12002	2	BEP23100	5	BEP22022	6	BEP14117	8	BEP14300	9
BEP12202	2	BEP23300	5	BEP22025	6	BEP14118	8	BEP14302	9
BEP12502	2	BEP23400	5	BEP22030	6	BEP14119	8	BEP12518	9
BEP14602	2	BEP23600	5	BEP22031	6	BEP12614	8	BEP12514	9
BEP14802	2	BEP23390	5	BEP22032	6	BEP12814	8	BEP12538	9
BEP14002	2	BEP23490	5	BEP22033	6	BEP12014	8	BEP12512	9
BEP14202	2	BEP23690	5	BEP22010	6	BEP12214	8	BEP12534	9
BEP14502	2	BEP23113	5	BEP22011	6	BEP14614	8	BEP14518	9
BEP12604	3	BEP23111	5	BEP22012	6	BEP14814	8	BEP14514	9
BEP12804	3	BEP23399	5	BEP22013	6	BEP14014	8	BEP14538	9
BEP12004	3	BEP23499	5	BEP22014	6	BEP14214	8	BEP14512	9
BEP12204	3	BEP23699	5	BEP22015	6	BEP12676	8	BEP14534	9
BEP12504	3	BEP23345	5	BEP22040	6	BEP12686	8	BEP14395	9
BEP14604	3	BEP23445	5	BEP22041	6	BEP12696	8	BEP14396	9
BEP14804	3	BEP23645	5	BEP22042	6	BEP12886	8	BEP14397	9
BEP14004	3	BEP23110	5	BEP22043	6	BEP12896	8	BEP14398	9
BEP14204	3	BEP23112	5	BEP22070	6	BEP12016	8	BEP12330	9
BEP14504	3	BEP23122	5	BEP22071	6	BEP12086	8	BEP12331	9
BEP12680	3	BEP23250	5	BEP22072	6	BEP12216	8	BEP12332	9
BEP12880	3	BEP23262	5	BEP22050	6	BEP12296	8	BEP12333	9
BEP12080	3	BEP23268	5	BEP22060	6	BEP12616	8	BEP12340	9
BEP12280	3	BEP23303	5	BEP22061	6	BEP12816	8	BEP12341	9
BEP12580	3	BEP23306	5	BEP20005	6	BEP14676	8	BEP12342	9
BEP14680	3	BEP23310	5	BEP20007	6	BEP14686	8	BEP12343	9
BEP14880	3	BEP23403	5	BEP13105	7	BEP14696	8	BEP14330	9
BEP14080	3	BEP23603	5	BEP13110	7	BEP14886	8	BEP14331	9
BEP14280	3	BEP23406	5	BEP13115	7	BEP14896	8	BEP14332	9
BEP14580	3	BEP23606	5	BEP13130	7	BEP14016	8	BEP14333	9
BEP41300	3	BEP23410	5	BEP13135	7	BEP14086	8	BEP14340	9
BEP41305	3	BEP23610	5	BEP13140	7	BEP14216	8	BEP14341	9
BEP41310	3	BEP21009	6	BEP13155	7	BEP14296	8	BEP14342	9
BEP41315	3	BEP21012	6	BEP13160	7	BEP14616	8	BEP14343	9
BEP41320	3	BEP21015	6	BEP13165	7	BEP14816	8	BEP14390	9
BEP41321	3	BEP21018	6	BEP13180	7	BEP12629	8	BEP14391	9
BEP41322	3	BEP21020	6	BEP13185	7	BEP12829	8	BEP14392	9
BEP41200	3	BEP21024	6	BEP13190	7	BEP12029	8	BEP14393	9
BEP41080	3	BEP21030	6	BEP13410	7	BEP12229	8	BEP12441	10

BEP12661	10	BEP12189	10	BEP10050	12	BEP10863	15	BEP35010	19
BEP12688	10	BEP14167	10	BEP10055	12	BEP10865	15	BEP35011	19
BEP12881	10	BEP14168	10	BEP10051	12	BEP10875	15	BEP35012	19
BEP12888	10	BEP14169	10	BEP10060	12	BEP10877	15	BEP35013	19
BEP14661	10	BEP14187	10	BEP10061	12	BEP10876	15	BEP35014	19
BEP14688	10	BEP14188	10	BEP10062	12	BEP10878	15	BEP35015	19
BEP14881	10	BEP14189	10	BEP10063	12	BEP11041	16	BEP35016	19
BEP14888	10	BEP12350	11	BEP10065	12	BEP10260	16	BEP35101	19
BEP12766	10	BEP12351	11	BEP10066	12	BEP10200	16	BEP35110	19
BEP12768	10	BEP12352	11	BEP10067	12	BEP10210	16	BEP35111	19
BEP12786	10	BEP12353	11	BEP10068	12	BEP10201	16	BEP35112	19
BEP12788	10	BEP12354	11	BEP10101	13	BEP10211	16	BEP35019	19
BEP12781	10	BEP12356	11	BEP11075	13	BEP10255	16	BEP35020	19
BEP12706	10	BEP14350	11	BEP11076	13	BEP10205	16	BEP35021	19
BEP12708	10	BEP14351	11	BEP11077	13	BEP10215	16	BEP35023	19
BEP12701	10	BEP14352	11	BEP11078	13	BEP10206	16	BEP35050	19
BEP12702	10	BEP14353	11	BEP10150	13	BEP10216	16	BEP35051	19
BEP12721	10	BEP14354	11	BEP10155	13	BEP10230	16	BEP35052	19
BEP12722	10	BEP14356	11	BEP10160	13	BEP10235	16	BEP35053	19
BEP14766	10	BEP14360	11	BEP10165	13	BEP10258	16	BEP35055	19
BEP14768	10	BEP65000	11	BEP10180	13	BEP10220	16	BEP35057	19
BEP14786	10	BEP65001	11	BEP10185	13	BEP10223	16	BEP35058	19
BEP14788	10	BEP65002	11	BEP10177	13	BEP10225	16	BEP11205	19
BEP14781	10	BEP65003	11	BEP10178	13	BEP10228	16	BEP11210	19
BEP14706	10	BEP65004	11	BEP10179	13	BEP11035	16	BEP18000	19
BEP14708	10	BEP65005	11	BEP10130	13	BEP11030	16	BEP40100	19
BEP14701	10	BEP10000	11	BEP10135	13	BEP16200	17	BEP40101	19
BEP14702	10	BEP10002	11	BEP10140	13	BEP16210	17	BEP40102	19
BEP14721	10	BEP12962	11	BEP16000	14	BEP11046	17	BEP40106	19
BEP14722	10	BEP12982	11	BEP16001	14	BEP11047	17	BEP40107	19
BEP12622	10	BEP12902	11	BEP16002	14	BEP16100	17	BEP15215	20
BEP12682	10	BEP12922	11	BEP16003	14	BEP16101	17	BEP15216	20
BEP12692	10	BEP14962	11	BEP16010	14	BEP16110	17	BEP15205	20
BEP12822	10	BEP14982	11	BEP16011	14	BEP16111	17	BEP15206	20
BEP12882	10	BEP14902	11	BEP16012	14	BEP35510	17	BEP15210	20
BEP12892	10	BEP14922	11	BEP16013	14	BEP35515	17	BEP15211	20
BEP12022	10	BEP12560	11	BEP16020	14	BEP41205	17	BEP15212	20
BEP12092	10	BEP12561	11	BEP16021	14	BEP16105	17	BEP15213	20
BEP12222	10	BEP12562	11	BEP16030	14	BEP16115	17	BEP15214	20
BEP12292	10	BEP12563	11	BEP16031	14	BEP35500	17	BEP15200	20
BEP14622	10	BEP12564	11	BEP16004	14	BEP35501	17	BEP15201	20
BEP14682	10	BEP12550	11	BEP16014	14	BEP35502	17	BEP15202	20
BEP14692	10	BEP12551	11	BEP10950	14	BEP35503	17	BEP15203	20
BEP14822	10	BEP12552	11	BEP10951	14	BEP35504	17	BEP15204	20
BEP14882	10	BEP12553	11	BEP10955	14	BEP35505	17	BEP15000	20
BEP14892	10	BEP12554	11	BEP16300	14	BEP10250	18	BEP15001	20
BEP14022	10	BEP14950	11	BEP16301	14	BEP11080	18	BEP15002	20
BEP14092	10	BEP12110	12	BEP16302	14	BEP10270	18	BEP15045	21
BEP14222	10	BEP12100	12	BEP16310	14	BEP16050	18	BEP15046	21
BEP14292	10	BEP12810	12	BEP16311	14	BEP16051	18	BEP15047	21
BEP12130	10	BEP12811	12	BEP16312	14	BEP16055	18	BEP15048	21
BEP12131	10	BEP14110	12	BEP10175	14	BEP16056	18	BEP15016	21
BEP14130	10	BEP14100	12	BEP10176	14	BEP10290	18	BEP15017	21
BEP14131	10	BEP14810	12	BEP11000	15	BEP10291	18	BEP15018	21
BEP12623	10	BEP14811	12	BEP10800	15	BEP10292	18	BEP15019	21
BEP12823	10	BEP12912	12	BEP10802	15	BEP10293	18	BEP15026	21
BEP12023	10	BEP12910	12	BEP10805	15	BEP10294	18	BEP15027	21
BEP12223	10	BEP12911	12	BEP10808	15	BEP10295	18	BEP15028	21
BEP14623	10	BEP12960	12	BEP10816	15	BEP10296	18	BEP15029	21
BEP14823	10	BEP12961	12	BEP10817	15	BEP10240	18	BEP15020	21
BEP14023	10	BEP12980	12	BEP10823	15	BEP10242	18	BEP15021	21
BEP14223	10	BEP12981	12	BEP10500	15	BEP10245	18	BEP15022	21
BEP12140	10	BEP14960	12	BEP10501	15	BEP10247	18	BEP15023	21
BEP12141	10	BEP14980	12	BEP10506	15	BEP10280	18	BEP15030	21
BEP14140	10	BEP12900	12	BEP10510	15	BEP10281	18	BEP15031	21
BEP14141	10	BEP12901	12	BEP10511	15	BEP10282	18	BEP15032	21
BEP12120	10	BEP10100	12	BEP10515	15	BEP10285	18	BEP15033	21
BEP12121	10	BEP10110	12	BEP10850	15	BEP65100	18	BEP15024	21
BEP14120	10	BEP10120	12	BEP10852	15	BEP65105	18	BEP15025	21
BEP14121	10	BEP10105	12	BEP10860	15	BEP65110	18	BEP15034	21
BEP12167	10	BEP10115	12	BEP10862	15	BEP55013	18	BEP15040	22
BEP12168	10	BEP10125	12	BEP10864	15	BEP35000	19	BEP15041	22
BEP12169	10	BEP11085	12	BEP10851	15	BEP35001	19	BEP15042	22
BEP12187	10	BEP49605	12	BEP10853	15	BEP35002	19	BEP15043	22
BEP12188	10	BEP49610	12	BEP10861	15	BEP35003	19	BEP15051	22

BEP15052	22	BEP26327	24	BEP24044	26	BEP31023	30	BEP43008	34
BEP15053	22	BEP26330	24	BEP24080	26	BEP30105	30	BEP43012	34
BEP15054	22	BEP26100	24	BEP24081	26	BEP31030	30	BEP43013	34
BEP15055	22	BEP26103	24	BEP24082	26	BEP30016	31	BEP43019	34
BEP15056	22	BEP26106	24	BEP24083	26	BEP30117	31	BEP43011	34
BEP15083	22	BEP26109	24	BEP24084	26	BEP31020	31	BEP43016	34
BEP15090	22	BEP26340	24	BEP24085	26	BEP30100	31	BEP43000	34
BEP15091	22	BEP26346	24	BEP24088	26	BEP30017	31	BEP43001	34
BEP15080	22	BEP28114	25	BEP24050	26	BEP30018	31	BEP43002	34
BEP15081	22	BEP28116	25	BEP24060	26	BEP30020	31	BEP43020	34
BEP15082	22	BEP28118	25	BEP24062	26	BEP30021	31	BEP43040	34
BEP15100	22	BEP28120	25	BEP24070	26	BEP30027	31	BEP43041	34
BEP15101	22	BEP28124	25	BEP24071	26	BEP30022	31	BEP44010	34
BEP15102	22	BEP28130	25	BEP34000	28	BEP30024	31	BEP44015	34
BEP15110	22	BEP28152	25	BEP34002	28	BEP30025	31	BEP44005	35
BEP15015	22	BEP28128	25	BEP34004	28	BEP31000	31	BEP44000	35
BEP15105	22	BEP28102	25	BEP34006	28	BEP30115	31	BEP44100	35
BEP15120	22	BEP28104	25	BEP34008	28	BEP30100	31	BEP44105	35
BEP15121	22	BEP28110	25	BEP34001	28	BEP30105	31	BEP44110	35
BEP15122	22	BEP28100	25	BEP34003	28	BEP30117	31	BEP44200	35
BEP27020	23	BEP28160	25	BEP34005	28	BEP30130	31	BEP44205	35
BEP27025	23	BEP28174	25	BEP34007	28	BEP30115	31	BEP44210	35
BEP27000	23	BEP28178	25	BEP31805	29	BEP30120	31	BEP44215	35
BEP27001	23	BEP28184	25	BEP31806	29	BEP30125	31	BEP48300	36
BEP27002	23	BEP28186	25	BEP31807	29	BEP30127	31	BEP44250	36
BEP27003	23	BEP28188	25	BEP31808	29	BEP30100	31	BEP44255	36
BEP27004	23	BEP28190	25	BEP31809	29	BEP30105	31	BEP43025	36
BEP27005	23	BEP28200	25	BEP31810	29	BEP30120	31	BEP48000	36
BEP27006	23	BEP28202	25	BEP31811	29	BEP30125	31	BEP43120	36
BEP27100	23	BEP28204	25	BEP31812	29	BEP30127	31	BEP43125	36
BEP27101	23	BEP28206	25	BEP31813	29	BEP20201	32	BEP43150	36
BEP27102	23	BEP28260	25	BEP31815	29	BEP20220	32	BEP42100	36
BEP27103	23	BEP28208	25	BEP31816	29	BEP15151	32	BEP42105	36
BEP27104	23	BEP28210	25	BEP31001	29	BEP15152	32	BEP65150	36
BEP27105	23	BEP28212	25	BEP31003	29	BEP15153	32	BEP47320	36
BEP27107	23	BEP28214	25	BEP31006	29	BEP20110	32	BEP70082	36
BEP29500	23	BEP28216	25	BEP31000	29	BEP65200	32	BEP70083	36
BEP29501	23	BEP28218	25	BEP31020	29	BEP22100	32	BEP70081	36
BEP29502	23	BEP28220	25	BEP31023	29	BEP22101	32	BEP48315	37
BEP29600	23	BEP28222	25	BEP31024	29	BEP22102	32	BEP48011	37
BEP29605	23	BEP28224	25	BEP31025	29	BEP22103	32	BEP48012	37
BEP29610	23	BEP28226	25	BEP31026	29	BEP28000	32	BEP48015	37
BEP29620	23	BEP28228	25	BEP31027	29	BEP29100	32	BEP70360	37
BEP29625	23	BEP28230	25	BEP31042	29	BEP29105	32	BEP70400	37
BEP29630	23	BEP28238	25	BEP31030	29	BEP20320	32	BEP70401	37
BEP25002	23	BEP28232	25	BEP30000	30	BEP20322	32	BEP70402	37
BEP27500	23	BEP28234	25	BEP30040	30	BEP17119	33	BEP70403	37
BEP27510	23	BEP28244	25	BEP30001	30	BEP17132	33	BEP70408	37
BEP26374	24	BEP28258	25	BEP30002	30	BEP17136	33	BEP70410	37
BEP26382	24	BEP28250	25	BEP30003	30	BEP17139	33	BEP70412	37
BEP26400	24	BEP28254	25	BEP30005	30	BEP17141	33	BEP70414	37
BEP26406	24	BEP28256	25	BEP30006	30	BEP17142	33	BEP70415	37
BEP26412	24	BEP28264	25	BEP30007	30	BEP17143	33	BEP70418	37
BEP26440	24	BEP26000	26	BEP30008	30	BEP17144	33	BEP70420	37
BEP26447	24	BEP26005	26	BEP30009	30	BEP17145	33	BEP48100	37
BEP26450	24	BEP26011	26	BEP30010	30	BEP17146	33	BEP48105	37
BEP26454	24	BEP26012	26	BEP30045	30	BEP17147	33	BEP48200	37
BEP26468	24	BEP26030	26	BEP30011	30	BEP17148	33	BEP48205	37
BEP26476	24	BEP26025	26	BEP31026	30	BEP17149	33	BEP48210	37
BEP26483	24	BEP26015	26	BEP31027	30	BEP17150	33	BEP70430	37
BEP26486	24	BEP24002	26	BEP30125	30	BEP17152	33	BEP70431	37
BEP26489	24	BEP24004	26	BEP30127	30	BEP17153	33	BEP70432	37
BEP41041	24	BEP24006	26	BEP31001	30	BEP17171	33	BEP70433	37
BEP26200	24	BEP24008	26	BEP31003	30	BEP17018	33	BEP70434	37
BEP26205	24	BEP24010	26	BEP31006	30	BEP17031	33	BEP48220	37
BEP26225	24	BEP24012	26	BEP31042	30	BEP17035	33	BEP42000	37
BEP26231	24	BEP24014	26	BEP30050	30	BEP17037	33	BEP48050	38
BEP26270	24	BEP24020	26	BEP30052	30	BEP17038	33	BEP48055	38
BEP26274	24	BEP24022	26	BEP30054	30	BEP20420	33	BEP48020	38
BEP26278	24	BEP24024	26	BEP31024	30	BEP20430	33	BEP48021	38
BEP26281	24	BEP24026	26	BEP31025	30	BEP29210	33	BEP47400	38
BEP26130	24	BEP24028	26	BEP30120	30	BEP29215	33	BEP47405	38
BEP26133	24	BEP24030	26	BEP30026	30	BEP29220	33	BEP47410	38
BEP26320	24	BEP24032	26	BEP30012	30	BEP20400	33	BEP47420	38
BEP26324	24	BEP24042	26	BEP30014	30	BEP29200	33	BEP47425	38

BEP47056	38	BEP60566	42	BEP56005	46	BEP70034	51	BEP82500	54
BEP47059	38	BEP60567	42	BEP56006	46	BEP70033	51	BEP82501	54
BEP47551	38	BEP60552	42	BEP52000	46	BEP70039	51	BEP82502	54
BEP47556	38	BEP60585	42	BEP52005	46	BEP70041	51	BEP80060	54
BEP47540	38	BEP60018	43	BEP52050	46	BEP70300	52	BEP80065	54
BEP47550	38	BEP60020	43	BEP54040	47	BEP70320	52	BEP82651	55
BEP47555	38	BEP60022	43	BEP54000	47	BEP70325	52	BEP82652	55
BEP47570	38	BEP60025	43	BEP54001	47	BEP70330	52	BEP82653	55
BEP47575	38	BEP60080	43	BEP54002	47	BEP70340	52	BEP82654	55
BEP40020	39	BEP60085	43	BEP54003	47	BEP70335	52	BEP82655	55
BEP40021	39	BEP60000	43	BEP54020	47	BEP70036	52	BEP82656	55
BEP40022	39	BEP60005	43	BEP54021	47	BEP70037	52	BEP82630	55
BEP40023	39	BEP60010	43	BEP54022	47	BEP47100	52	BEP82679	55
BEP40025	39	BEP60015	43	BEP54030	47	BEP47101	52	BEP82682	55
BEP40026	39	BEP60011	43	BEP54031	47	BEP70140	52	BEP82684	55
BEP40027	39	BEP60016	43	BEP52010	47	BEP70135	52	BEP82686	55
BEP40029	39	BEP60555	43	BEP52008	47	BEP70133	52	BEP82688	55
BEP40031	39	BEP60556	43	BEP52021	47	BEP70125	52	BEP82600	55
BEP40009	39	BEP60040	43	BEP50004	47	BEP70124	52	BEP82605	55
BEP41013	39	BEP60041	43	BEP50002	47	BEP70123	52	BEP82610	55
BEP41014	39	BEP60042	43	BEP50064	48	BEP70136	52	BEP27500	55
BEP41015	39	BEP60043	43	BEP50000	48	BEP70137	52	BEP27510	55
BEP41040	39	BEP60044	43	BEP50003	48	BEP70138	52	BEP80100	55
BEP41045	39	BEP60550	43	BEP50009	48	BEP70139	52	BEP80105	55
BEP41052	39	BEP60557	43	BEP50020	48	BEP70141	52	BEP80106	55
BEP41058	39	BEP60560	43	BEP50025	48	BEP70142	52	BEP80107	55
BEP41053	39	BEP60050	44	BEP50018	49	BEP70143	52	BEP80103	55
BEP41062	39	BEP60055	44	BEP50060	49	BEP70190	53	BEP80104	55
BEP41025	39	BEP60057	44	BEP50017	49	BEP70195	53	BEP80110	55
BEP41026	39	BEP60060	44	BEP50013	49	BEP70134	53	BEP80108	55
BEP41027	39	BEP60062	44	BEP50023	49	BEP70144	53	BEP80109	55
BEP43090	39	BEP60075	44	BEP50030	50	BEP48500	53	BEP80120	55
BEP43095	39	BEP60077	44	BEP50031	50	BEP48505	53	BEP80122	55
BEP49100	40	BEP60070	44	BEP50035	50	BEP70350	53	BEP80124	55
BEP49105	40	BEP60120	44	BEP54110	50	BEP70355	53	BEP80126	55
BEP49110	40	BEP60121	44	BEP50032	50	BEP70351	53		
BEP49115	40	BEP60122	44	BEP50036	50	BEP70193	53		
BEP49130	40	BEP60126	44	BEP50051	50	BEP70150	53		
BEP49150	40	BEP60350	44	BEP50050	50	BEP60295	53		
BEP49605	40	BEP60425	44	BEP50055	50	BEP60296	53		
BEP49610	40	BEP60420	44	BEP58110	50	BEP70170	53		
BEP49200	40	BEP54100	44	BEP58100	50	BEP70171	53		
BEP49205	40	BEP55004	45	BEP50044	50	BEP70172	53		
BEP49230	40	BEP55005	45	BEP50045	50	BEP70173	53		
BEP49300	40	BEP55006	45	BEP50040	50	BEP20555	53		
BEP49305	40	BEP55007	45	BEP50041	50	BEP50150	53		
BEP49418	41	BEP55008	45	BEP54200	50	BEP50155	53		
BEP49438	41	BEP55087	45	BEP54210	50	BEP50160	53		
BEP49458	41	BEP55088	45	BEP50071	50	BEP50165	53		
BEP49410	41	BEP55089	45	BEP50072	50	BEP50140	54		
BEP49405	41	BEP55002	45	BEP50075	50	BEP50145	54		
BEP49435	41	BEP55003	45	BEP50076	50	BEP50131	54		
BEP49455	41	BEP55001	45	BEP50077	50	BEP81001	54		
BEP49400	41	BEP54105	45	BEP70015	51	BEP81006	54		
BEP49430	41	BEP54106	45	BEP70011	51	BEP81011	54		
BEP49500	41	BEP42050	45	BEP70012	51	BEP82300	54		
BEP49530	41	BEP42051	45	BEP70510	51	BEP82302	54		
BEP49600	41	BEP55091	45	BEP70511	51	BEP82304	54		
BEP49505	41	BEP55092	45	BEP70512	51	BEP82305	54		
BEP49535	41	BEP55100	45	BEP70500	51	BEP82320	54		
BEP49615	41	BEP55101	45	BEP70501	51	BEP82322	54		
BEP60570	42	BEP55102	45	BEP70502	51	BEP82324	54		
BEP60571	42	BEP55103	45	BEP70520	51	BEP82340	54		
BEP60572	42	BEP55015	46	BEP70522	51	BEP82350	54		
BEP60573	42	BEP55043	46	BEP70521	51	BEP82352	54		
BEP60528	42	BEP55025	46	BEP70526	51	BEP82354	54		
BEP60574	42	BEP52015	46	BEP70515	51	BEP82360	54		
BEP60575	42	BEP55044	46	BEP70516	51	BEP82364	54		
BEP60576	42	BEP55110	46	BEP70010	51	BEP82366	54		
BEP60577	42	BEP55050	46	BEP70019	51	BEP82380	54		
BEP60526	42	BEP56000	46	BEP70017	51	BEP82386	54		
BEP60522	42	BEP56001	46	BEP70030	51	BEP82390	54		
BEP60524	42	BEP56002	46	BEP70032	51	BEP80080	54		
BEP60564	42	BEP56003	46	BEP70035	51	BEP80082	54		
BEP60565	42	BEP56004	46	BEP70038	51	BEP80084	54		

## Choose the Gear Ratio that's Best for Your Vehicle:

When selecting a Gear Ratio, you should consider the following:

1. Tire Size
2. Transmission Ratio
3. Final Gear Ratio
4. Engine RPM at Cruise Speed

The following formula has been developed to calculate the optimum final Gear Ratio to suit your application:

$$\frac{\text{M.P.H. X Gear Ratio}}{\text{Tire Diameter}} \times 336 = \text{rpm } \underline{\hspace{2cm}}$$

The chart shown below shows RPM calculations at 55 MPH for various combinations of final Gear Ratio and Tire Diameter.

According to this chart, the acceptable RPM range is 2000-3000 which is represented by the entire shaded area of the chart. The optimum RPM range is 2300-2600, and it is represented by the white area between the two red areas. When changing ratios to improve mileage, choose a ratio within the red shaded band above the optimum range. When changing ratios to improve power, choose a ratio within the red shaded band below the optimum range.

Gear Ratio	Tire Diameter																
	24	25	26	27	28	29	30	31	32	33	34	35	36	38	40	42	44
2.56	1972	1892	1820	1752	1690	1631	1577	1526	1478	1434	1391	1352	1314	1245	1183	1126	1075
2.73	2102	2018	1940	1869	1802	1740	1682	1627	1577	1529	1484	1441	1401	1328	1261	1201	1147
2.94	2264	2173	2090	2012	1942	1874	1811	1753	1698	1646	1599	1552	1509	1429	1358	1294	1235
3.08	2372	2277	2189	2108	2033	1963	1897	1836	1779	1725	1674	1626	1581	1498	1423	1355	1294
3.21	2472	2373	2282	2197	2119	2046	1977	1914	1854	1798	1745	1695	1648	1561	1483	1412	1348
3.31	2549	2447	2353	2266	2185	2110	2039	1973	1912	1854	1799	1748	1699	1610	1529	1456	1390
3.42	2633	2528	2433	2341	2257	2179	2107	2039	1975	1915	1859	1806	1756	1663	1580	1505	1436
3.54	2726	2617	2516	2423	2336	2256	2181	2110	2044	1982	1924	1869	1817	1722	1635	1558	1487
3.73	2872	2757	2651	2553	2462	2377	2298	2224	2154	2089	2027	1969	1915	1814	1723	1641	1567
3.90	3003	2883	2772	2669	2574	2485	2402	2325	2252	2184	2120	2059	2002	1897	1802	1716	1638
4.10	3157	3031	2914	2806	2706	2613	2526	2444	2368	2296	2228	2165	2105	1994	1894	1804	1722
4.27	3288	3156	3035	2923	2818	2721	2630	2545	2466	2391	2321	2255	2192	2077	1973	1879	1793
4.56	3511	3371	3291	3121	3010	2906	2809	2718	2633	2554	2478	2408	2341	2218	2107	2006	1915
4.88	3758	3607	3459	3340	3221	3110	3006	2909	2818	2733	2652	2577	2505	2373	2255	2147	2050
5.29	4073	3910	3760	3621	3491	3371	3259	3154	3055	2962	2875	2793	2716	2573	2444	2328	2222
5.38	4143	3977	3824	3682	3551	3428	3314	3207	3107	3013	2924	2841	2762	2616	2486	2367	2260
5.71	4397	4221	4058	3908	3769	3639	3517	3404	3298	3198	3104	3015	2931	2777	2638	2512	2398
6.17	4751	4561	4385	4223	4072	3932	3801	3678	3563	3455	3354	3258	3167	3001	2851	2715	2591
7.17	5521	5300	5096	4907	4732	4569	4417	4274	4141	4015	3897	3786	3681	3487	3313	3155	3011

SOME OF THE PARTS LISTED IN THIS CATALOG ARE NOT MANUFACTURED BY THE ORIGINAL EQUIPMENT MANUFACTURER AND ANY REFERENCE TO TRADEMARKS ARE FOR CROSS REFERENCE PURPOSES ONLY. NO REPRESENTATION IS MADE WITH RESPECT TO THE SOURCE OF MANUFACTURE OF ANY PARTICULAR PART.