

BIG END

PERFORMANCE PRODUCTS

RACING & PERFORMANCE
EQUIPMENT CATALOG



TABLE OF CONTENTS

FUEL DELIVERY	2
POWER ADDERS	15
GAUGES	18
BODY & SAFETY	21
DRIVELINE	26
CHASSIS / SUSPENSION	32
ADDITIVES & CHEMICALS	33
ENGINE COMPONENTS	34
HEAT PROTECTION	39
GASKETS	40
COOLING	42
IGNITION	45
DRESS-UP PARTS	51
EXHAUST	54
INDEX	55

LIFTING EYE
(3 PLACES)

GLOW-PLUG
HARNESS

CDR
VALVE



ALUMINUM HOSE ENDS

- Constructed from lightweight 6061 alloy aluminum
- Designed for smooth flow, easy assembly & longer life
- Elbow ends built from one-pc. billet-tube construction
- Viton O-ring seal allows 360 degree rotation
- 37 degree AN flare assures a leak proof seal
- Compatible with all AN adapter fittings



STRAIGHT

Red/Blue Straight Swivel

BEP12600	-6 AN
BEP12800	-8 AN
BEP12000	-10 AN
BEP12200	-12 AN
BEP12500	-16AN NEW!

Black Straight Swivel

BEP14600	-6 AN
BEP14800	-8 AN
BEP14000	-10 AN
BEP14200	-12 AN
BEP14500	-16AN NEW!

45 DEGREE

Red/Blue 45° Swivel

BEP12645	-6 AN
BEP12845	-8 AN
BEP12045	-10 AN
BEP12245	-12 AN
BEP12545	-16AN NEW!

Black 45° Swivel

BEP14645	-6 AN
BEP14845	-8 AN
BEP14045	-10 AN
BEP14245	-12 AN
BEP14545	-16AN NEW!

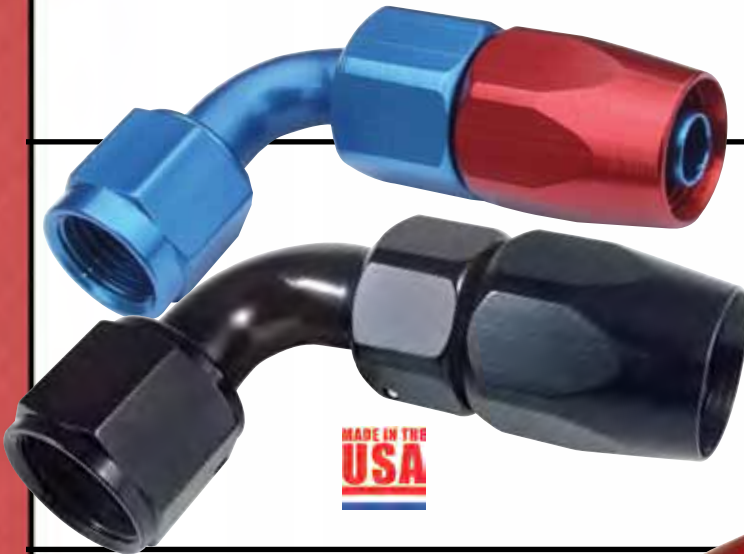
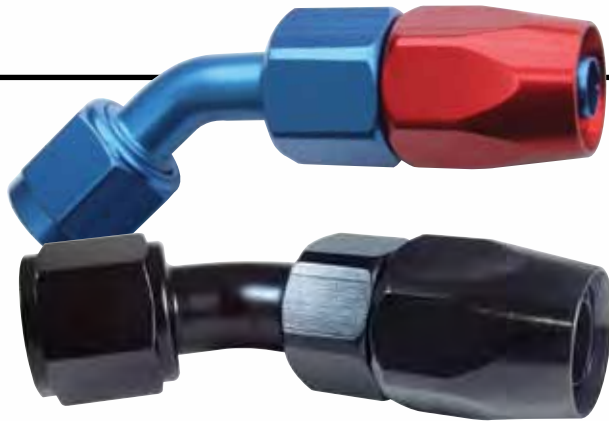

90 DEGREE

Red/Blue 90° Swivel

BEP12690	-6 AN
BEP12890	-8 AN
BEP12090	-10 AN
BEP12290	-12 AN
BEP12590	-16AN NEW!

Black 90° Swivel

BEP14690	-6 AN
BEP14890	-8 AN
BEP14090	-10 AN
BEP14290	-12 AN
BEP14590	-16AN NEW!



120 DEGREE

Red/Blue 120° Swivel

BEP12602	-6AN
BEP12802	-8AN
BEP12002	-10AN
BEP12202	-12AN
BEP12502	-16AN

Black 120° Swivel

BEP14602	-6AN
BEP14802	-8AN
BEP14002	-10AN
BEP14202	-12AN
BEP14502	-16AN

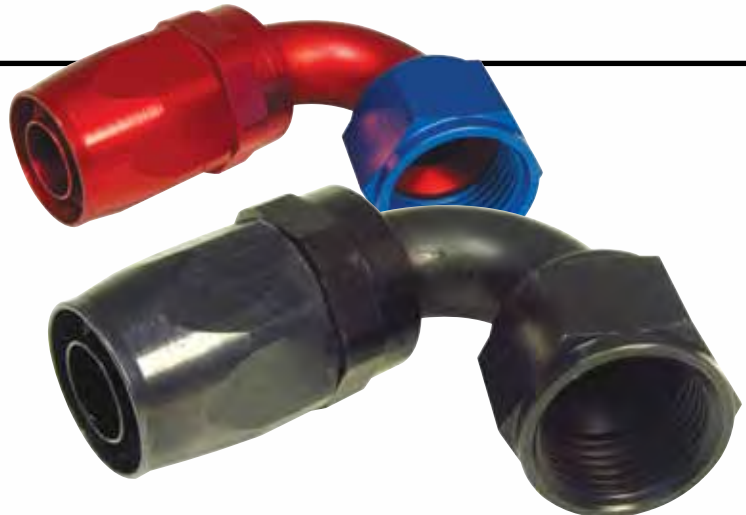

NEW!





NEW!

150 DEGREE

Red/Blue 150° Swivel	Black 150° Swivel
BEP12604 -6AN	BEP14604 -6AN
BEP12804 -8AN	BEP14804 -8AN
BEP12004 -10AN	BEP14004 -10AN
BEP12204 -12AN	BEP14204 -12AN
BEP12504 -16AN	BEP14504 -16AN

180 DEGREE

Red/Blue 180° Swivel	Black 180° Swivel
BEP12680 -6 AN	BEP14680 -6 AN
BEP12880 -8 AN	BEP14880 -8 AN
BEP12080 -10 AN	BEP14080 -10 AN
BEP12280 -12 AN	BEP14280 -12 AN
BEP12580 -16AN NEW!	BEP14580 -16AN NEW!



MANUFACTURED BY:
KOUL tools U.S.A.



HOSE ASSEMBLY TOOLS

- Precision tool that installs rubber stainless steel braided hose on the fitting.
- | | |
|-----------------|---|
| BEP41300 | Small Kit (-4, -6, -8AN) |
| BEP41305 | Large Kit (-10, -12, -16AN) |
| BEP41310 | Hot Rod Kit (-6, -8, -10AN) |
| BEP41315 | Pro Combo Kit (-4, -6, -8, -10, -12, -16AN) |
| BEP41320 | 6AN Kit |
| BEP41321 | 8AN Kit |
| BEP41322 | 10AN Kit |

HIGH QUALITY PRODUCTS
PRICED RIGHT!

BIG END
MEANS BIG VALUE!

BILLET AN WRENCH SET

- 3/8" thick 6061-T6 billet aluminum
- Laser etched with fitting sizes
- Complete set from sizes 4 through 12.

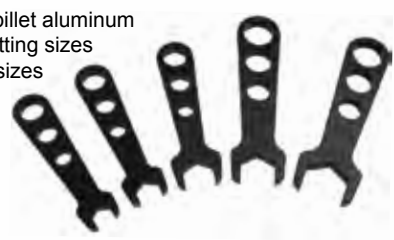

BEP41200 AN Wrench Set

ADJUSTABLE AN ALUMINUM WRENCHES

- Prevent scratching of aluminum anodized hose ends & fittings during installation and removal.
- Billet aluminum, blue anodized



BEP41080 -3AN to -8AN Wrench
BEP41081 -3AN to -20AN Wrench

PUSH-LOC FULL SWIVEL HOSE ENDS

- Constructed from lightweight 6061 alloy aluminum
- Avoid twisting or kinking your lines during installation.
- Lightweight and economical.
- Assemble fast and trouble-free.
- Use with ONLY Flex-Loc Push-On hose.

NEW!

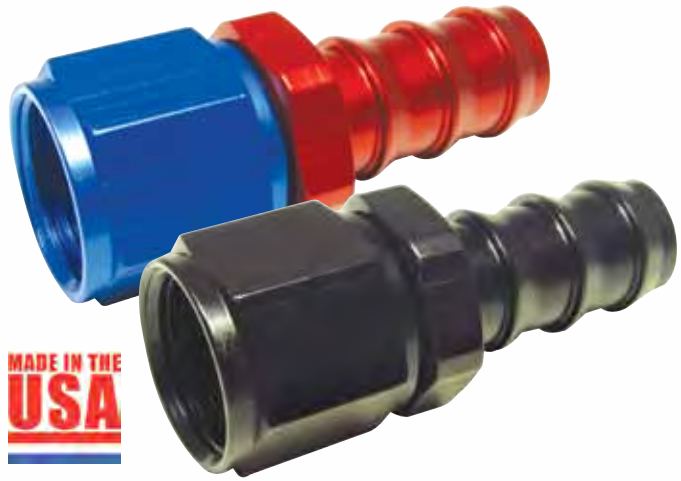

STRAIGHT

Red/Blue Straight Swivel
BEP13401 -6 AN
BEP13402 -8 AN
BEP13403 -10 AN

Black Straight Swivel
BEP13451 -6 AN
BEP13452 -8 AN
BEP13453 -10 AN

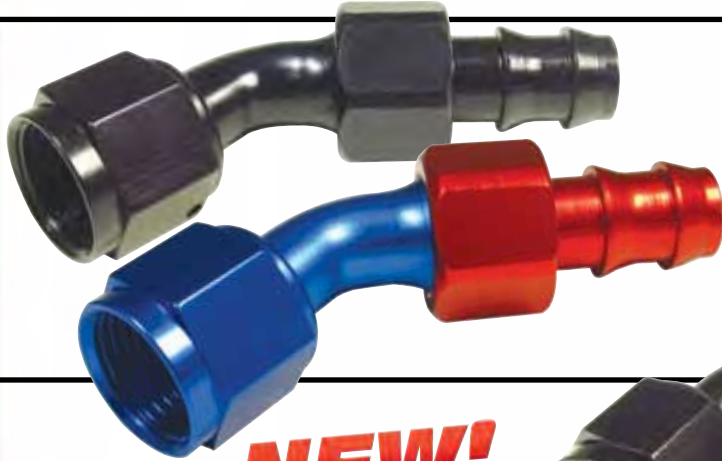

NEW!

45 DEGREE

Red/Blue 45° Swivel
BEP13406 -6 AN
BEP13407 -8 AN
BEP13408 -10 AN

Black 45° Swivel
BEP13456 -6 AN
BEP13457 -8 AN
BEP13458 -10 AN

90 DEGREE

NEW!

Red/Blue 90° Swivel
BEP13411 -6 AN
BEP13412 -8 AN
BEP13413 -10 AN

Black 90° Swivel
BEP13461 -6 AN
BEP13462 -8 AN
BEP13463 -10 AN

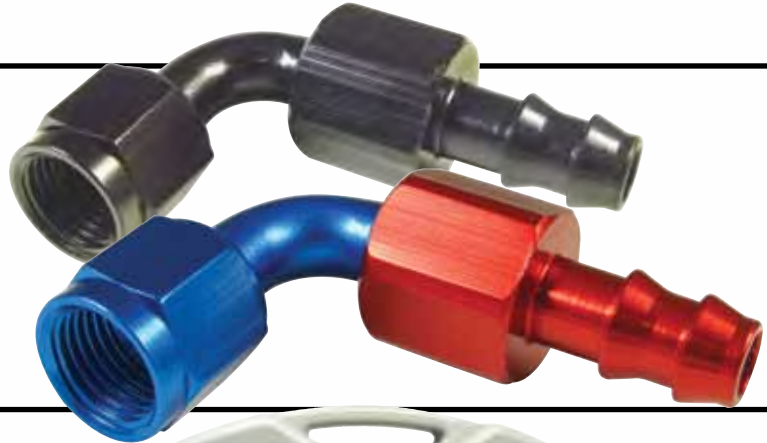

EZ-ON HOSE PRESS

- Makes installing push-on fittings easy!
- Will install -4 thru -16 push-on hose onto fittings in seconds.
- Constructed from investment cast steel.
- Comes with a custom carrying case for safe storage and transportation.

MANUFACTURED BY:
KOUL tools
NEW!



BEP41330 Ez-On Hose Press Tool

FLEX-FUEL HOSE

- Our 30R9 Flex-Fuel Hose is designed to handle today's various fuels and pump-pressures.
- Supports operating temperatures from -30° to 275° F.
- Superior race fuel compatability including: ethanol, extended fuels, E85, diesel and bio-diesel.
- Constructed with black nylon and thin, stainless steel braid.

10' Length, Black
BEP13502 -6 AN
BEP13507 -8 AN
BEP13512 -10 AN

20' Length, Black
BEP13504 -6 AN
BEP13509 -8 AN
BEP13514 -10 AN



FLEX-LOC PUSH-ON HOSE, BLUE

- Feature a Class-A high oil resistant nitrile inner tube with a reinforcing two spiral aramid fiber and a nitrile / PVC cover resistant to oil and petroleum-based products.
- Operates at 250 PSI and a temp. range of -30° F to 160° F.
- Not recommended for use with unleaded gasoline, brake fluids or power steering fluids.



NEW!

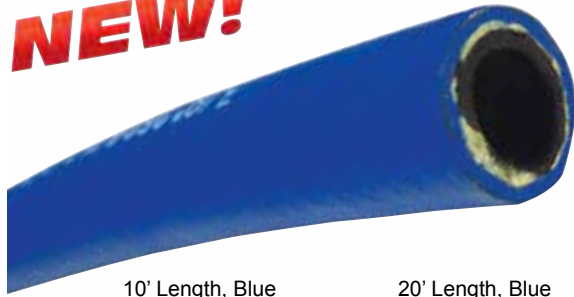

10' Length, Blue	20' Length, Blue
BEP13105 -6 AN	BEP13130 -6 AN
BEP13110 -8 AN	BEP13135 -8 AN
BEP13115 -10 AN	BEP13140 -10 AN

FLEX-LOC PUSH-ON HOSE, BLACK



NEW!

10' Length, Black	20' Length, Black
BEP13155 -6 AN	BEP13180 -6 AN
BEP13160 -8 AN	BEP13185 -8 AN
BEP13165 -10 AN	BEP13190 -10 AN



STAINLESS STEEL BRAIDED HOSE

- Constructed of a durable CPE synthetic rubber tube bonded with a woven nylon braid and secured by a 308 stainless outer braid
- Resists extreme heat, abrasion & corrosion
- Compatible with alcohol & petroleum based fuels, motor oil & coolant
- Operating temps from -40° F - 350° F

AN	Ins. Dia.	Outs. Dia.	Min. Bend	10'	20'
-6	0.34	0.55	2.5"R	BEP13610	BEP13620
-8	0.43	0.6	3.5" R	BEP13810	BEP13820
-10	0.56	0.79	4" R	BEP13010	BEP13020
-12	0.69	0.94	4.5" R	BEP13210	BEP13220
NEW! -16	0.88	1.16	5.5" R	BEP13310	--- --- ---

BLACK NYLON LIGHTWEIGHT BRAIDED HOSE

- Made to the same high quality standards as our stainless steel hose using an outer braid of lightweight, oil resistant, quality black nylon fiber w/ inner liner.
- Rated to a maximum pressure of 350 psi on all sizes, and operating temp range of up to 275° F, making this the perfect choice for almost any customer.
- Can be used with fuel, oil, and antifreeze.



AN	In. Dia.	Out. Dia.	Min. Bend	10' NEW!	20'
-6	0.34	0.55	2.5"R	BEP13622	BEP13621
-8	0.43	0.6	3.5" R	BEP13822	BEP13821
-10	0.56	0.79	4" R	BEP13022	BEP13021
-12	0.69	0.94	4.5" R	BEP13222	BEP13221

DUAL INLET CARBURETOR LINE KITS

- Comes pre-assembled! Just tighten and install
- 1/8" NPT port for gauge provision
- Inlet gaskets included

Blue / Red Finish w/ Stainles Steel Hose

- BEP12112** -6 Kit Holley Ultra HP
- BEP12113** -6 Kit Demon w/ 9/16" - 24 Bowl Fittings
- BEP12114** -8 Kit Holley Dominator 4500
- BEP12115** -8 Kit Holley 4150 Series
- BEP12116** -6 Kit Holley 4160, 8-21/32" Centers
- BEP12117** -6 Kit Holley 4150 series
- BEP12118** -8 Inlet Kit Demon w/ 9/16-24 Bowl Fittings
- BEP12119** -8 Kit Holley Ultra HP

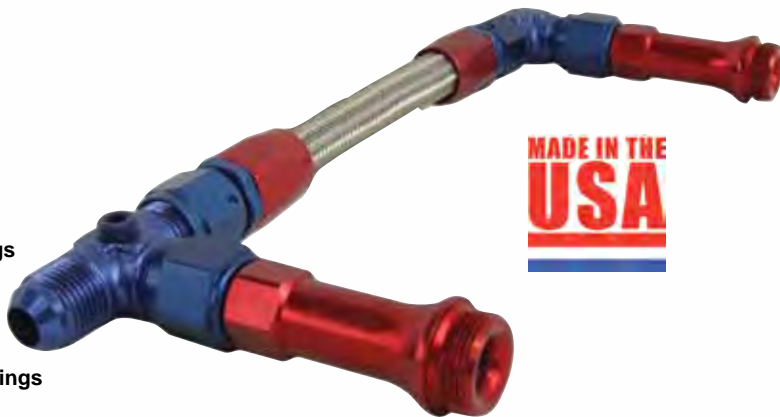

MAY BE SHOWN WITH MODIFICATIONS CARBURETOR IS NOT INCLUDED

Black Fittings w/ Black Hose

- BEP14102** -6 Kit Holley Ultra HP
- BEP14104** -8 Kit Holley Dominator 4500
- BEP14105** -8 Kit Holley 4150 Series
- BEP14107** -6 Kit Holley 4150 Series
- BEP14109** -8 Kit Holley Ultra HP



Black Finish w/ Stainles Steel Hose

- BEP14112** -6 Kit Holley Ultra HP
- BEP14113** -6 Kit Demon w/ 9/16" - 24 Bowl Fittings
- BEP14114** -8 Kit Holley Dominator 4500
- BEP14115** -8 Kit Holley 4150 series
- BEP14116** -6 Kit Holley 4160, 8-21/32" Centers
- BEP14117** -6 Kit Holley 4150 series
- BEP14118** -8 Kit Demon w/ 9/16-24 Bowl Fittings
- BEP14119** -8 Kit Holley Ultra HP



STRAIGHT ADAPTER FITTINGS

- 3/7" AN flare fits standard AN ends, sold each.

- | | | |
|-----------------|-----------------|--------------------|
| Blue | Black | |
| BEP12676 | BEP14676 | 1/4" NPT to -6 AN |
| BEP12686 | BEP14686 | 3/8" NPT to -6 AN |
| BEP12696 | BEP14696 | 1/2" NPT to -6 AN |
| BEP12886 | BEP14886 | 3/8" NPT to -8 AN |
| BEP12896 | BEP14896 | 1/2" NPT to -8 AN |
| BEP12016 | BEP14016 | 3/8" NPT to -10 AN |
| BEP12086 | BEP14086 | 1/2" NPT to -10 AN |
| BEP12216 | BEP14216 | 1/2" NPT to -12 AN |
| BEP12296 | BEP14296 | 3/4" NPT to -12 AN |
| BEP12616 | BEP14616 | 1/8" NPT to -6 AN |
| BEP12816 | BEP14816 | 1/4" NPT to -8 AN |

PORT PLUGS w/ O-RING

- Used to plug open ports.
- Sold each.

- | | | |
|-----------------|-----------------|--------|
| Blue | Black | |
| BEP12614 | BEP14614 | -6 AN |
| BEP12814 | BEP14814 | -8 AN |
| BEP12014 | BEP14014 | -10 AN |
| BEP12214 | BEP14214 | -12 AN |



AN FLARE CAPS

- | | | |
|-----------------|-----------------|--------|
| Blue | Black | |
| BEP12629 | BEP14629 | -6 AN |
| BEP12829 | BEP14829 | -8 AN |
| BEP12029 | BEP14029 | -10 AN |
| BEP12229 | BEP14229 | -12 AN |





HARD TUBE ADAPTERS

Blue	Black	
BEP12310	BEP14310	3/8 Tube to -6 Female
BEP12315	BEP14315	3/8 Tube to -6 Male
BEP12320	BEP14320	1/2 Tube to -8 Female
BEP12325	BEP14325	1/2 Tube to -8 Male

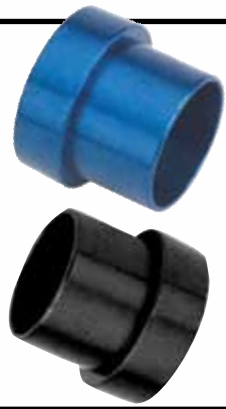

TUBE SLEEVES



Blue	
BEP12619	-6 Sleeve, Pair
BEP12819	-8 Sleeve, Pair
BEP12019	-10 Sleeve, Each
Black	
BEP14619	-6 Sleeve, Pair
BEP14819	-8 Sleeve, Pair
BEP14019	-10 Sleeve, Each

TUBE NUTS

Blue	
BEP12618	-6 Tube Nut, 2/pkg.
BEP12818	-8 Tube Nut, 2/pkg.
BEP12018	-10 Tube Nut, Each
Black	
BEP14618	-6 Tube Nut, 2/pkg.
BEP14818	-8 Tube Nut, 2/pkg.
BEP14018	-10 Tube Nut, Each



STRAIGHT FEMALE AN SWIVEL COUPLER

Blue	Black	
BEP12306	BEP14306	-6 Female
BEP12308	BEP14308	-8 Female
BEP12300	BEP14300	-10 Female
BEP12302	BEP14302	-12 Female



MALE FLARE UNION

Blue	Black	
BEP12615	BEP14615	-6 Male
BEP12815	BEP14815	-8 Male
BEP12015	BEP14015	-10 Male
BEP12215	BEP14215	-12 Male



ALLEN SOCKET PIPE PLUGS

Blue	Black	
BEP12518	BEP14518	1/8" NPT, 2/pkg.
BEP12514	BEP14514	1/4" NPT, 2/pkg.
BEP12538	BEP14538	3/8" NPT, 2/pkg.
BEP12512	BEP14512	1/2" NPT, 1/pkg.
BEP12534	BEP14534	3/4" NPT, 1/pkg.



FEMALE TO MALE EXPANDERS AND REDUCERS

- These expanders and reducers allow you to go up or down one AN size easily, especially when trying to go a size larger or smaller on a pre-welded fitting such as with a fuel cell.

Blue	Black	
Expanders		
BEP12330	BEP14330	4 AN to 6 AN
BEP12331	BEP14331	6 AN to 8 AN
BEP12332	BEP14332	8 AN to 10 AN
BEP12333	BEP14333	10 AN to 12 AN
Reducers		
BEP12340	BEP14340	6 AN Female to 4 AN Male
BEP12341	BEP14341	8 AN Female to 6 AN Male
BEP12342	BEP14342	10 AN Female to 8 AN Male
BEP12343	BEP14343	12 AN Female to 10 AN Male



TEFLON SEALING WASHERS

- Replacement washers for Big End fuel cell bulkhead fittings available from -6 through -12.

BEP14395	Teflon Washer #6
BEP14396	Teflon Washer #8
BEP14397	Teflon Washer #10
BEP14398	Teflon Washer #12

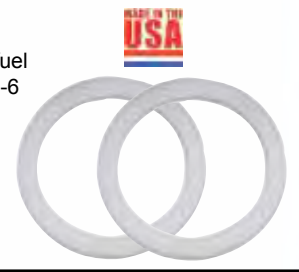

FUEL CELL BULKHEADS

- Made from 6061-T6 Aluminum, these fuel cell bulkheads include a nut and Teflon washers. - Black anodized finish.

BEP14390	Fuel Cell Bulkhead #6
BEP14391	Fuel Cell Bulkhead #8
BEP14392	Fuel Cell Bulkhead #10
BEP14393	Fuel Cell Bulkhead #12



GAUGE ADAPTERS

- 1/8" NPT gauge port adapter fittings. AN to AN or NPT to AN

Blue	Black	
BEP12441	-----	4 F to -4 M, 1/8" NPT Port
BEP12661	BEP14661	-6 F to -6 M, 1/8" NPT Port
BEP12688	BEP14688	3/8" NPT M to -6 M, 1/8" NPT Port
BEP12881	BEP14881	-8 F to -8 M, 1/8" NPT Port
BEP12888	BEP14888	3/8" NPT M to -8 M, 1/8" NPT Port



AN RADIUS PORT ADAPTERS WITH O-RING

- For maximum flow. Sold each

Blue	Black	
BEP12766	BEP14766	-6 Port to -6 AN
BEP12768	BEP14768	-6 Port to -8 AN
BEP12786	BEP14786	-8 Port to -6 AN
BEP12788	BEP14788	-8 Port to -8 AN
BEP12781	BEP14781	-8 Port to -10 AN
BEP12706	BEP14706	-10 Port to -6 AN
BEP12708	BEP14708	-10 Port to -8 AN
BEP12701	BEP14701	-10 Port to -10 AN
BEP12702	BEP14702	-10 Port to -12 AN
BEP12721	BEP14721	-12 Port to -10 AN
BEP12722	BEP14722	-12 Port to -12 AN



90 DEGREE

Blue	Black	
BEP12622	BEP14622	1/8" NPT to -6 AN
BEP12682	BEP14682	1/4" NPT to -6 AN
BEP12692	BEP14692	3/8" NPT to -6 AN
BEP12822	BEP14822	1/4" NPT to -8 AN
BEP12882	BEP14882	3/8" NPT to -8 AN
BEP12892	BEP14892	1/2" NPT to -8 AN
BEP12022	BEP14022	1/2" NPT to -10 AN
BEP12092	BEP14092	3/4" NPT to -10 AN
BEP12222	BEP14222	1/2" NPT to -12 AN
BEP12292	BEP14292	3/4" NPT to -12 AN

FUEL PUMP FITTINGS

- These inverted flare fittings are the perfect way to finish off your fuel system with a leak free connection and a professional look.

Blue	
BEP12130	Adapter -6 x 1/2-20
BEP12131	Adapter -6 x 5/8-18
Black	
BEP14130	Adapter -6 x 1/2-20
BEP14131	Adapter -6 x 5/8-18



45 DEGREE

Blue	Black	
BEP12623	BEP14623	1/4" NPT to -6 AN
BEP12823	BEP14823	3/8" NPT to -8 AN
BEP12023	BEP14023	1/2" NPT to -10 AN
BEP12223	BEP14223	3/4" NPT to -12 AN

FUEL RAIL FITTINGS

- Fuel Injection Fittings allow the use of stock fuel rails with AN style lines.

Blue	
BEP12140	#6AN to 14MM x 1.5 O-Ring
BEP12141	#6AN to 16MM x 1.5 O-Ring
BEP12142	Fuel Fitting Kit, Blue
Black	
BEP14140	#6AN to 14MM x 1.5 O-Ring
BEP14141	#6AN to 16MM x 1.5 O-Ring
BEP14142	Fuel Fitting Kit, Black



CARBURETOR INLET ADAPTERS

- Blue or black anodized

Blue	Black	
BEP12167	BEP14167	-6 AN to Edelbrock and Carter AFB, Each
BEP12168	BEP14168	-6 AN to 7/8-20 Holley Dual Inlet 2/pkg
BEP12169	BEP14169	-6 AN to 9/16-24 BG Demon and Holley Single Inlet, 2/pkg.
BEP12187	BEP14187	-8 AN to 7/8-20 Holley Dual Inlet short style, 2/pkg.
BEP12188	BEP14188	-8 AN to 7/8-20 Holley Dual Inlet Long style, 2/pkg.
BEP12189	BEP14189	-8 AN to 9/16-24 BG Demon and Holley Single Inlet, 2/pkg.



CARB EXTENSION FITTINGS

- Long style female carb inlet adapters
- Sold in pairs

Blue	
BEP12120	Holley 7/8-20 to 8AN Female
BEP12121	Holley 7/8-20 to 6AN Female
Black	
BEP14120	Holley 7/8-20 to 8AN Female
BEP14121	Holley 7/8-20 to 6AN Female



AN Y-FITTINGS

- CNC Machined, 6061-T6 aluminum

Blue, Male Y-Fitting

- BEP12350** -6 in/ Dual -6 out
- BEP12351** -8 in/ Dual -6 out
- BEP12352** -8 in/ Dual -8 out
- BEP12353** -10 in/ Dual -8 out
- BEP12354** -10 in/ Dual -10 out
- BEP12356** -12 in/ Dual -12 out

Black, Male Y-Fitting

- BEP14350** -6 in/ Dual -6 out
- BEP14351** -8 in/ Dual -6 out
- BEP14352** -8 in/ Dual -8 out
- BEP14353** -10 in/ Dual -8 out
- BEP14354** -10 in/ Dual -10 out
- BEP14356** -12 in/ Dual -12 out

Black, Female Y-Block

- BEP14360** -10 in/ Dual -8 out



INSULATED CLAMPS

- Aluminum clamps insulated with Adel rubber material
- Makes mounting fuel lines and wiring easy

- BEP65000** 1/4" I.D. , 20 Pk.
- BEP65001** 3/8" I.D. , 20 Pk.
- BEP65002** 1/2" I.D. , 15 Pk.
- BEP65003** 5/8" I.D. , 12 Pk.
- BEP65004** 3/4" I.D. , 10 Pk.
- BEP65005** 1" I.D. , 6 Pk.



ALUMINUM FUEL LINE

- Provides more fuel volume to the carburetor.
- Legal in all racing classes
- 25 ft. long rolls

- BEP10000** 3/8" Line Tubing
- BEP10001** 1/2" Line Tubing
- BEP10002** 5/8" Line Tubing

HIGH QUALITY PRODUCTS
PRICED RIGHT!
BIG END
MEANS BIG VALUE!

ONE-WAY CHECK VALVES

- Compatible with all fuels, oils and coolants
- Functions in demanding environments
- High grade lightweight materials
- Less restrictive hinged flapper style design
- Low opening pressure: 2 P.S.I.
- Operating pressure range: 2 - 1500 P.S.I.
- Operating temperature range: -30° TO 400° F



- | | | | |
|-----------------|-----|-----------------|-----|
| Blue | | Black | |
| BEP12962 | #6 | BEP14962 | #6 |
| BEP12982 | #8 | BEP14982 | #8 |
| BEP12902 | #10 | BEP14902 | #10 |
| BEP12922 | #12 | BEP14922 | #12 |



ALUMINUM WELDING BUNGS

- Made from 6061 Aluminum, bungs are un-anodized and lipped to prevent warpage
- Available in Male AN and Female NPT

- | | | | |
|-----------------|--------------------|-----------------|---------------------------|
| BEP12560 | Male Weld Bung #6 | BEP12550 | Female NPT Weld Bung 1/8" |
| BEP12561 | Male Weld Bung #8 | BEP12551 | Female NPT Weld Bung 1/4" |
| BEP12562 | Male Weld Bung #10 | BEP12552 | Female NPT Weld Bung 3/8" |
| BEP12563 | Male Weld Bung #12 | BEP12553 | Female NPT Weld Bung 1/2" |
| BEP12564 | Male Weld Bung #16 | BEP12554 | Female NPT Weld Bung 3/4" |

COMPLETE AN HOSE PRESSURE TEST KIT

- Allows you test all of your an hose assemblies before you put them on your car.
- Includes an air valve and matching plug for each size from -3 through -16 and comes in a convenient clear plastic case to store it all in.
- Can be used with either compressed air or nitrogen.

- BEP14950** Pressure Test Kit, 3AN - 16AN



BILLET IN-LINE RACE FUEL FILTERS

- Lightweight billet 6061-T6 aircraft aluminum
- 150 gph at 9 psi for fuel injection or carbureted applications
- 10 micron cellulose element or 100 micron s/s pleated element
- Blue or black anodized finish with laser etched logo
- Size: 1-3/4" x 6-1/2"



Blue	Black	
BEP12110	BEP14110	-10 AN 10 Micron Cellulose
BEP12100	BEP14100	-10 AN 100 Micron Stainless
BEP12810	BEP14810	-8 AN 10 Micron Cellulose
BEP12811	BEP14811	-8 AN 100 Micron Stainless
BEP12912	Replacement O-ring	
BEP12910	Replacement Cellulose 10 Micron	
BEP12911	Replacement Stainless 100 Micron	

BILLET IN-LINE STREET FILTERS



- Made from lightweight billet 6061-T6 aircraft aluminum
- Designed for carbureted systems, filters flow 95 gph at 7 PSI and have a reusable 40-micron element
- Precision CNC machined 2 piece construction
- -6 AN is 1-3/4" x 3-3/4"
- -8 AN is 1-1/4" x 4"

BEP12960	-6 AN Blue
BEP12961	-6 AN Machined, Polished
BEP12980	-8 AN Blue
BEP12981	-8 AN Machined, Polished
BEP14960	-6 Black
BEP14980	-8 Black
BEP12900	Replacement O-ring
BEP12901	Replacement Filter Screen

MECHANICAL STREET FUEL PUMPS

- 80 GPH
- Shut off pressure: 7 1/2 psi
- 1/4" NPT inlet/outlet ports
- Shiny finish

Street Pumps	
BEP10100	SBC 80 GPH
BEP10110	BBC 80 GPH
BEP10120	SBF Windsor 80 GPH



MECHANICAL STREET/STRIP FUEL PUMPS

- 110 GPH (free-flow)
- Shut off pressure: 6 1/2 - 8 psi
- Inlet and outlet are 3/8" NPT
- Shiny finish

Street / Strip	
BEP10105	SBC 110 GPH
BEP10115	BBC 110 GPH
BEP10125	SBF Windsor 110 GPH

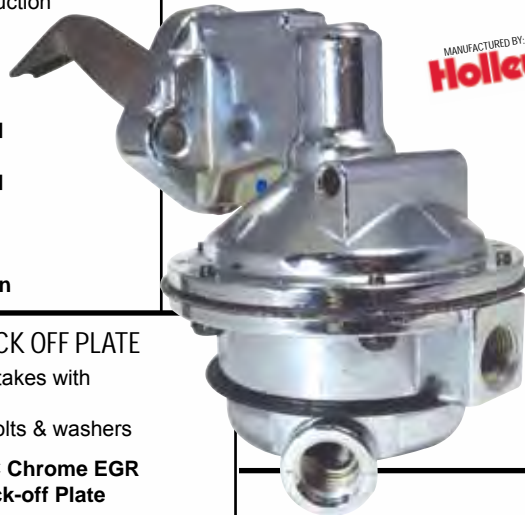

DON'T FORGET THE GASKETS!

BEP49605	F.P. Gasket, 10pk.
BEP49610	F.P. Mounting Plate Gasket, 10pk.

CHROME EGR BLOCK OFF PLATE

- For all SB Chevy intakes with EGR provision
- Mounting gasket, bolts & washers



BEP11085	SBC Chrome EGR Block-off Plate
----------	--------------------------------

CHROME FUEL BLOCK OFF PLATES

- Chrome plated steel, includes mounting gasket



BEP10050	SB Chevy
BEP10055	BB Chevy, Ford (exc. 351C-400), Mopar, Pontiac, Olds

FUEL PUMP MOUNTING PLATE

- For 265-400 SB Chevy
- Chrome plated steel
- Gasket included



BEP10051	Mounting Plate
----------	----------------

BILLET FUEL PUMP BLOCK OFF PLATES

- Made of CNC Machined 6061-T6 billet aluminum
- Anodized finish

SB Chevrolet	
BEP10060	Aluminum
BEP10061	Blue
BEP10062	Red
BEP10063	Black

BB Chevrolet, Ford & Mopar	
BEP10065	Aluminum
BEP10066	Blue
BEP10067	Red
BEP10068	Black
(All Ford except 351C, M400)	



LIGHTWEIGHT FUEL PUMP PUSHROD

- Designed for high RPM cast iron core camshafts.
- Lightweight design prevents float over 6000 rpm.
- Machined from 4130 chrome moly tubing.



BEP10101 Fuel Pump Pushrod



HIGH FLOW CHROME CANISTER FILTERS

- 10 micron paper element flows up to 90 gph @ 9psi
- 3/8" NPT inlet and outlet ports.
- Not for use with fuel injection

- BEP11075 Competition Filter**
BEP11076 Element for 11075
BEP11077 Street / Strip Filter
BEP11078 Element for 11077



ELECTRIC FUEL PUMPS

STREET PUMP

- **95 GPH free flow!**
- Factory set at 7 PSI
- 3/8" NPT inlet and outlet ports

BEP10150 Street Pump

STREET / STRIP PUMP

- 110 GPH free flow (Capable of 14 PSI)
- Factory set at 7 PSI
- 3/8" NPT inlet and outlet ports
- Includes regulator.

BEP10155 Street/Strip Pump w/ Regulator

RACING PUMP

- **130 GPH free flow!**
- Max pressure of 14 PSI
- Compatible w/ Alcohol & Methanol
- 3/8" NPT inlet and outlet ports

BEP10160 Racing Pump

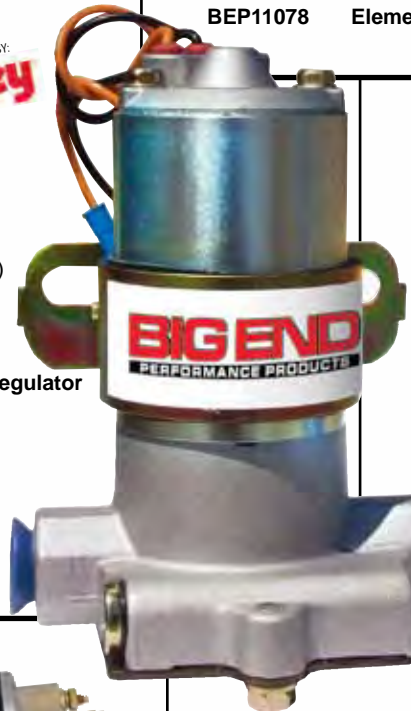

FUEL PRESSURE REGULATOR

- Adjustable from 4 1/2 – 9 PSI
- 3/8" N PT inlet and outlet ports
- Complete with mounting bracket and hardware

BEP10165 Fuel Pressure Regulator



INLINE EFI FUEL PUMP - 45 GPH

- Ideal for late model engine swaps and for use as a booster pump in a nitrous oxide application.
- 5/16" barbed hose ends.
- Includes two cushioned mounting clamps.
- This pump is rated to 500 hp naturally aspirated and flows 45 GPH @ 40 psi

BEP10180 EFI Inline Pump, 45 GPH

ELECTRIC FUEL PUMPS

- Works well as a fuel transfer pump and makes a great standalone or booster pump.
- Compatible with all fuels and additives.
- Solid-state worry free electronics.
- Eliminates vapor lock and flooding.

- BEP10130 Gas, 4-7 PSI**
BEP10135 Gas, 2-3.5 PSI
BEP10140 Diesel, 4-7 PSI



NEW!



INLINE EFI FUEL PUMP - 70 GPH

- High performance, high flow rate pump that can support up to 900 hp on a carbureted N/A engine to 500 hp on a forced induction EFI engine.
- Features a -8AN female inlet and -6AN female outlet.
- Comes complete with two t-bar mounting clamps.
- This pump flows 110 gph free flow with a rating of 70 GPH @45 PSI

BEP10185 EFI Inline Pump, 70 GPH

**HIGH QUALITY PRODUCTS
 PRICED RIGHT!**

**BIG END
 MEANS BIG VALUE!**

CARBURETOR ADAPTER KIT

- Adapts Holley or AFB 4-bbl carb to Quadrajets manifold or flips over to adapt Quadrajets carb to Holley or AFB 4bbl
- Die-cast aluminum 1" adapter
- All gaskets & hardware included



BEP11000 Carburetor Adapter Kit



BILLET CARB SPACERS

- CNC machined from billet aluminum making them ultra-light.
- Precision bored to match carburetor base plates for a precise fit.

Open Center

BEP10500	.500" 4150-Style
BEP10501	1.00" 4150 Style
BEP10502	2.00" 4150 Style
BEP10505	.500", 4500 Style
BEP10506	1.00" 4500 Style
BEP10507	2.00" 4500 Style

4-Hole

BEP10510	.500" 4150 Style
BEP10511	1.00" 4150 Style
BEP10515	.500" 4500-Style
BEP10516	1.00" 4500-Style

CARBURETOR BASE GASKETS

- Made of durable heat-resistant nitrile rubber compound
- 1/16" Thick; Die-cut for an exact base mounting fit
- 10 per package



- BEP10800** Holley 4150, 4160 4bbl, Carter AFB, Open Hole, 10 Pk.
- BEP10802** Holley 4150, 4160 4bbl, Carter AFB, 4-Hole, 10 Pk.
- BEP10805** Holley 4150, 4160, Carter AFB, Edelbrock, 4bbl non-stick pair pack
- BEP10808** Quadrajets, Open Hole, 10 Pk
- BEP10816** Holley 4500 Dominator, 4-Hole, 10 Pk.
- BEP10817** Holley 4500 Dominator, Open Hole, 10 Pk.
- BEP10823** Holley 2 barrel 2300 series open 10 Pk.

HI-TECH SPACERS

- Made of a space-age phenolic material that thermally insulates between the intake manifold & carburetor
- CNC machined to exact tolerances

4150 Series Flange

BEP10850	4-Hole, 1/2" Tall Carb Spacer
BEP10852	4-Hole, 1" Tall Carb Spacer
BEP10860	Open, 1/2" Tall Carb Spacer
BEP10862	Open, 1" Tall Carb Spacer
BEP10864	Open, 2" Tall Carb Spacer

4500 Series Flange

BEP10851	4-Hole, 1/2" Tall Carb Spacer
BEP10853	4-Hole, 1" Tall Carb Spacer
BEP10861	Open, 1/2" Tall Carb Spacer
BEP10863	Open, 1" Tall Carb Spacer
BEP10865	Open, 2" Tall Carb Spacer



4150 Series Carbs
BEP10875 1" Spacer
BEP10877 2" Spacer



4500 Series Carbs
BEP10876 1" Spacer
BEP10878 2" Spacer

BIG FLOW 3-D CARB SPACERS

- Adds 10 to 50 horsepower and consistent E.T.'s
- 3-D, 4 hole contoured design features a flow enhancer cavity that increases flow under the carb, and aids in consistency when used under throttle stops
- Isolates heat from intake to carb, and withstands temps up to 400 degrees

BILLET ALUMINUM THROTTLE CABLE BRACKETS WITH RETURN SPRINGS

- CNC Machined from aircraft quality 6061-T6 billet aluminum
- Furnished with a specialty designed adjustable carburetor throttle cable end that is specifically machined to fit a GM Snap, Ford, Lokar, or Morse throttle cables to fine tune the perfect cable tension
- Complete with stainless hardware

Holley 4150/4160 Series		Holley 4500 Dominator Series	
BEP16000	GM snap cables	BEP16010	GM snap cables
BEP16001	Lokar cables	BEP16011	Lokar cables
BEP16002	Morse cables	BEP16012	Morse cables
BEP16003	Ford cables	BEP16013	Ford cables

Black Anodized Brackets

BEP16020	Fits Edel/ 4150 Carb, Accepts GM Cable
BEP16021	Fits Edel/ 4150 Carb, Accepts Lokar Cable
BEP16030	Fits 4500 Carb, Accepts GM Cable
BEP16031	Fits 4500 Carb, Accepts Lokar Cable

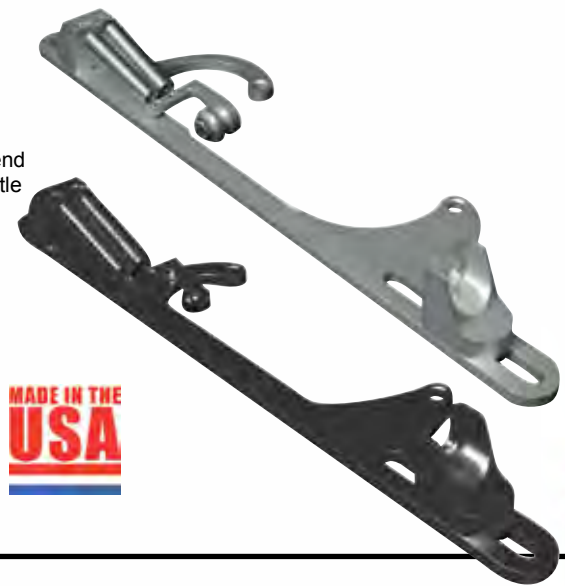

BILLET ALUMINUM THROTTLE RETURN BRACKETS

- CNC Machined from aircraft quality 6061-T6 billet aluminum
- Each bracket is equipped with dual stainless steel return springs and a fully adjustable billet aluminum mount
- Securely mounts to the carburetor base studs
- Hard coat clear anodized finish protects from corrosion
- Comes complete with stainless steel hardware



BEP16004 Holley 4150 / 4160
BEP16014 Holley 4500 Dominator



BILLET ALUMINUM FUEL PRESSURE REGULATOR MOUNTING BRACKETS

- CNC-machined from 6061-T6 billet aluminum.
- Directly mounts to carburetor base studs. Bracket bolt patterns are drilled to accept Holley, Aeromotive, and Magnafuel 2-port regulators
- Includes stainless steel hardware
- Hard coat clear anodized finish protects from corrosion



BEP16300



REGULATOR ARE NOT INCLUDED

DOMINATOR SHEAR PLATES

- Feature a 7 degree tapered bore designed to help make the Dominator perform at its peak
- CNC-machined from 6061-T6 billet aluminum
- Hard clear anodized finish protects from corrosion



BEP10950 2" Bore
BEP10951 2-1/4" Bore
BEP10955 1-3/4" Bore

Holley 4150 / 4160 Series Carburetors

BEP16300	Aeromotive Regulators
BEP16301	Holley Regulators / BEP10165
BEP16302	Magnafuel, Small 2-Port

Holley 4500 Dominator Series

BEP16310	Aeromotive Regulators
BEP16311	Holley Regulators / BEP10165
BEP16312	Magnafuel, Small 2-Port



BILLET CARBURETED FUEL PRESSURE REGULATOR

- Carbureted handles pressure range from 3-12 PSI.
- -6 AN o-ring boss inlet and outlet port sizes and has an 1/8" npt gauge port on the front of the regulator
- Includes mounting bracket
- Black anodized
- Gas or alcohol compatible.

BEP10175 Carbureted Regulator



BILLET EFI FUEL PRESSURE REGULATOR

- EFI handles pressure range from 30-65 PSI
- -6 AN o-ring boss inlet and outlet port sizes and has an 1/8" npt gauge port on the front of the regulator
- Includes mounting bracket
- Black anodized
- Laser-etched Big End logo
- Gas or alcohol compatible.

BEP10176 EFI Regulator

THROTTLE CABLE BRACKET AND RETURN SPRING KIT

- Stainless steel throttle cable bracket for a clean hot rod-performance look
- Mounts to carburetor stud
- Dual stainless steel return springs
- For use with Big End S/S Throttle Cable Assemblies



BEP11041 Throttle Cable Bracket Kit

FUEL BOWL GASKETS

- Feature a Fluorocarbon release blue non-stick coating
- Fits Holley 2300, 4150, and 4500 model carburetors

- BEP10200 Fuel Bowl Gaskets, 2/pkg.**
- BEP10210 Fuel Bowl Gaskets, 10/pkg.**
- BEP10201 Fuel Bowl Gaskets 4500 Series, 2/pkg.**
- BEP10211 Fuel Bowl Gaskets 4500 Series, 10/pkg.**

METERING BLOCK GASKETS

- Feature a Fluorocarbon release blue non-stick coating
- Fits Holley 4150, 4160, 2300, 2 and 3-circuit 4500 carbs

- BEP10205 Metering Block Gaskets, 2/pkg.**
- BEP10215 Metering Block Gaskets, 10/pkg.**
- BEP10206 Metering Bk Gaskets 4500 3 Circuit, 2/pkg**
- BEP10216 Metering Bk Gaskets 4500 3 Circuit, 10/pkg**

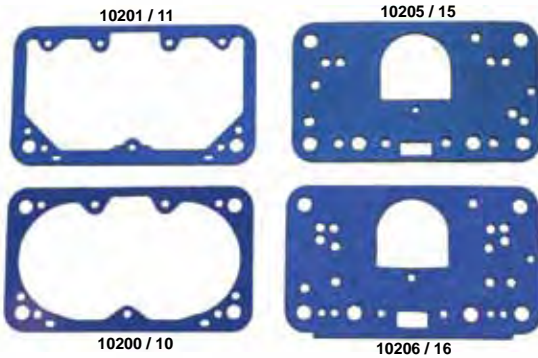

FUEL BOWL INLET FITTINGS

- Fits all Holley center-hung fuel bowls
- Inverted flare 7/8-20 x 5/8-18 for 3/8 tube dual feed lines
- Steel plug with zinc plating with gasket



BEP10260 Fuel Bowl Fitting, ea.

POWER VALVE PLUG

- Fits all Holley carburetors where fuel enrichment from the power valve is not desired in race applications
- Kit includes threaded plug and gasket



BEP10255 Power Valve Plug



NYLON FLOAT BOWL WASHER KIT

- High compression washers are unaffected by fuel and alcohol
- Will not tear or deteriorate like standard fiber washers



BEP10230 Nylon Float Bowl Washers, 10pk.

VACUUM SECONDARY DIAPHRAGM

- Made from high quality rubber
- Replacement for most vacuum secondary Holley Carburetors



BEP10235 Vacuum Secondary Diaphragm

VACUUM SECONDARY SPRING KIT

- Comes with 7 different springs ranging from super light to heavy.



BEP10258 Vacuum Secondary Spring Kit

ACCELERATOR PUMP DIAPHRAGMS

- Available in both rubber and alcohol safe GFLT material
- Both 30cc and 50cc available.
- Sold individually



- BEP10220 30cc Rubber Pump Diaphragm**
- BEP10223 30cc GFLT Pump Diaphragm**
- BEP10225 50cc Rubber Pump Diaphragm**
- BEP10228 50cc GFLT Pump Diaphragm**

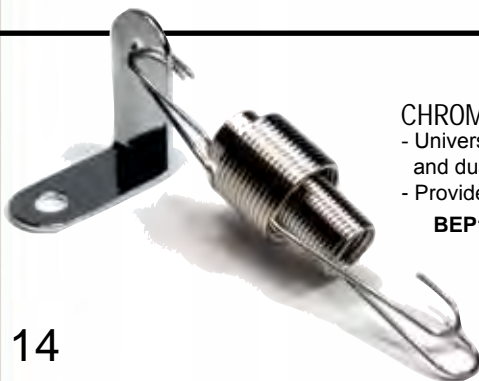

- CHROME DUAL RETURN SPRING KIT**
- Universal plated steel mounting bracket and dual spring kit
- Provides instant throttle return

BEP11030 Universal Throttle Return Spring Kit

CARB MONTED THROTTLE RETURN SPRING KIT

- Fits Holley 2300/4150/4160 carburetors
- Bracket is chrome plated steel
- Springs and mounting hardware included



BEP11035 Throttle Return Spring Kit

CLEAR FUEL BOWL SIGHT PLUGS

- Make quick checks & adjustments
- Includes 2 clear plugs with viton o-rings



BEP10250 Clear Sight Plugs, 2pk.

PLASTIC CARBURETOR COVER CAP

- Molded plastic and resistant to gasoline
- Keep debris out of your carb in storage.
- Includes wing bolt.



BEP11080 Plastic Carb Cap Cover, 5-1/8" Necks

CARBURETOR JET ASSORTMENT KIT

- Standard 1/4- 32 Holley jets
- Contains 2 ea. of 36 jets in sizes 64-99
- Plastic case with labeled compartments

BEP10270 Carb Jet Assortment Kit

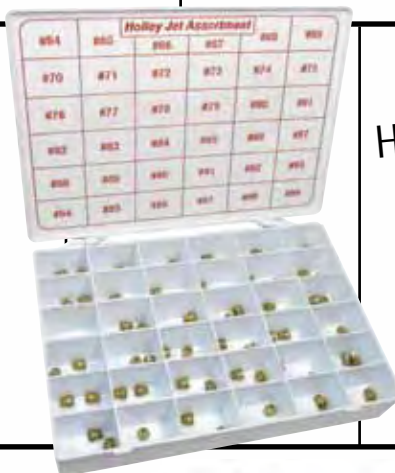

HIGH QUALITY PRODUCTS
PRICED RIGHT!
BIG END
MEANS BIG VALUE!

BILLET ALUMUNUM KICK DOWN DETENT CABLE BRACKETS

- Attaches to the bottom of our throttle brackets using stainless steel hardware
- Fully adjustable to fine tune the perfect cable tension
- CNC machined from billet aluminum
- Hard coat clear anodized finish protects against corrosion

BEP16050 GM snap cable
BEP16051 Lokar cable
BEP16055 GM Snap Cable, Black
BEP16056 Lokar Cable, Black



PERFORMANCE CARB REBUILD KITS

- Includes precision die-cut gaskets, non-stick on Holley style kits; needle and seat assemblies; and accelerator pump diaphragms.
- Many applications including Edelbrock and Holley carbs

BEP10240 4150 Double Pump Carbs
BEP10242 4160 Vacuum Secondary Carbs
BEP10245 2300 Series 2bbl Carbs
BEP10247 Edelbrock/ AFB Style Carbs



POWER VALVES

- Available in many vacuum ranges
- Sold individually with a gasket

BEP10290 2.5"
BEP10291 3.5"
BEP10292 4.5"
BEP10293 5.5"
BEP10294 6.5"
BEP10295 7.5"
BEP10296 8.5"



CARBURETOR STUD KIT

- Bright zinc-plated threaded 5/16"-18 at one end and 5/16"-24 on the other end
- Each package contains: 4 studs, 4 nuts, 4 washers

BEP65100 Standard, 1-3/8" Length
BEP65105 Long, 2" Length
BEP65110 Extra long, 3" Length



NEEDLE AND SEAT ASSEMBLIES

- Viton needles stand up to all gasoline applications using center hung floats
- Sold individually

BEP10280 Viton .097
BEP10281 Viton .110
BEP10282 Viton .120
BEP10285 Hardware Kit



VACUUM CAP KIT

- Colored vinyl vacuum line cap kit

BEP55013 Vacuum Cap Kit, 20 Pc.



WIDE OPEN THROTTLE MICRO SWITCH & MOUNTING BRACKET

- Lightweight billet aluminum and are precision fit to your carb for precise activation of the microswitch
- Includes stainless steel mounting hardware for the microswitch as well as for mounting the bracket
- Available for 4150/4160 and 4500 series carburetors.
- Black anodized finish



BEP16200 WOT & Bracket, Holley 4150 / 4160
BEP16210 WOT & Bracket, Holley 4500 Dominator

BILLET NITROUS / FUEL BRACKETS WITH THROTTLE KIT

- Features a billet nitrous/fuel bracket combined with a throttle cable mount & dual return springs. Plus an additional nitrous/fuel solenoid mounting bracket, for an all-in-one installation
- CNC machined from 6061-T6 billet aluminum
- Easily mounts to the carburetor studs on Holley 4150/4160 or a 4500 Dominator series carburetor
- Fully adjustable throttle and return spring brackets
- Includes s/s springs, and s/s mounting hardware.
- Hard clear anodized finish protects against corrosion



Holley 4150 / 4160 Series Carburetors
BEP16100 Billet Brackets w/ Throttle Kit, GM snap cable
BEP16101 Billet Brackets w/ Throttle Kit, Lokar cable



Holley 4500 Dominator Series Carb
BEP16110 Billet Brackets w/ Throttle Kit, GM snap cable
BEP16111 Billet Brackets w/ Throttle Kit, Lokar cable

POLISHED ALUMINUM FUEL CELLS

- Our fuel cells feature a sump bottom.
- -8 vent, -8 return -10 outlets

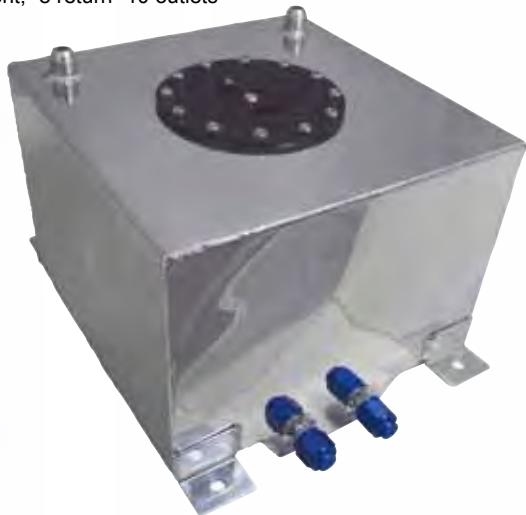

BEP11205 5 Gallon Fuel Cell, 12" x 12" x 9.5"
BEP11210 10 Gallon Fuel Cell, 16.5" x 16.5" x 11"

S/S THROTTLE CABLE ASSEMBLY

- Teflon inner liner and stainless braided outer covering
- Aluminum ends with threaded nut assembly and on the throttle cable bracket
- Aluminum clevis and swivel throttle stud
- Universal, trim-to-fit



BEP11046 24" (Fits Most Single Carburetors)
BEP11047 36" (Fits Most Tunnel Ram, Blower, & EFI Applications)

BILLET NITROUS / FUEL SOLENOID BRACKET KIT

- CNC machined from 6061-T6 billet aluminum
- Mounts any single nitrous/fuel solenoid using stainless steel hardware
- Easily mounts to the carburetor studs on Holley 4150/4160 or 4500 Dominator series carburetor.
- Hard clear anodized finish protects from corrosion
- Sold as a pair

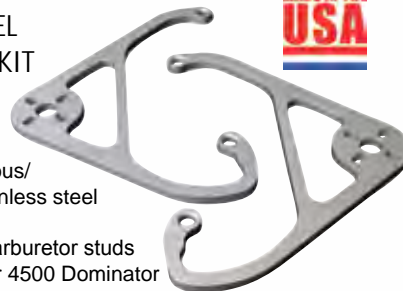

BEP16105 Nitrous/Fuel Solenoid Bracket Kit, Holley 4150/4160, Pair
BEP16115 Nitrous/Fuel Solenoid Bracket Kit, Holley 4500 Dominator, Pair

ASSEMBLED NITROUS FEED LINES

- Make plumbing your nitrous system a snap.
- Each line is made from a PTFE core stainless steel line with crimped on ends with either blue (nitrous) or red (fuel) fittings crimped on and tested to ensure there are no leaks.
- Choose from many lengths and sizes.



Blue Lines		Red Lines	
BEP35000	#3AN x 8.5"	BEP35101	#3AN x 12"
BEP35001	#3AN x 12"	BEP35110	#4AN x 8.5"
BEP35002	#3AN x 18"	BEP35111	#4AN x 12"
BEP35003	#3AN x 24"	BEP35112	#4AN x 18"
BEP35010	#4AN x 8.5"		
BEP35011	#4AN x 12"		
BEP35012	#4AN x 18"		
BEP35013	#4AN x 24"		
BEP35014	#4AN x 3'		
BEP35015	#4AN x 4'		
BEP35016	#4AN x 6'		
BEP35019	#4AN x 12'		
BEP35020	#4AN x 14'		
BEP35021	#4AN x 16'		
BEP35023	#4AN x 20'		
BEP35050	#6AN x 12"		
BEP35051	#6AN x 24"		
BEP35052	#6AN x 4'		
BEP35053	#6AN x 6'		
BEP35055	#6AN x 10'		
BEP35057	#6AN x 14'		
BEP35058	#6AN x 16'		



STAINLESS STEEL T-BOLT CLAMPS

- Feature full-round edges that prevent damage to delicate tubing and hoses.
- Also include an upgraded one-piece stainless steel trunion.
- These clamps offer a much more secure and stronger clamping than conventional worm gear clamps.
- Offered in sizes from 1.12" through 5.56", they are the perfect complement to our silicone couplers.



	Description	Grip Range
BEP37000	T-bolt Clamp 1.00"	1.12" - 1.25"
BEP37001	T-bolt Clamp 1.25"	1.50" - 1.64"
BEP37002	T-bolt Clamp 1.50"	1.63" - 1.88"
BEP37003	T-bolt Clamp 1.75"	1.88" - 2.12"
BEP37004	T-bolt Clamp 2.00"	2.13" - 2.37"
BEP37005	T-bolt Clamp 2.25"	2.44" - 2.75"
BEP37006	T-bolt Clamp 2.50"	2.69" - 3.00"
BEP37008	T-bolt Clamp 3.00"	3.31" - 3.63"
BEP37010	T-bolt Clamp 3.50"	3.63" - 3.94"
BEP37012	T-bolt Clamp 4.00"	4.12" - 4.44"
BEP37014	T-bolt Clamp 4.50"	4.81" - 5.12"
BEP37016	T-bolt Clamp 5.00"	5.25" - 5.56"

NITROUS DISTRIBUTION BLOCKS

- These distribution blocks are machined from 6061 billet aluminum and feature 1, 1/8" NPT inlet and 4, 1/8" NPT outlets.

BEP35510 Dist. Block, Blue
 BEP35515 Dist. Block, Red



NITROUS COMBO WRENCH

- Wrench includes all fitting sizes needed for nitrous systems on one handle.
- Machined out of one piece of billet aluminum and has the capability of tightening 3AN, 4AN, 6AN, and 1-1/4" bottle nuts.
- Black anodized and laser etched for easy size identification.



BEP41205 Nitrous Combo Wrench



FILTERED NITROUS FITTINGS

- These adapter fittings include a filter screen machined into them to keep any particles out of your nitrous system.

BEP35500 1/8" - #4 N2O Filter, Blue
 BEP35501 1/8" - #4 N2O Fuel Filter, Red
 BEP35502 1/4" - #4 N2O Filter, Blue
 BEP35503 1/8" - #6 N2O Filter, Blue
 BEP35504 1/4" - #6 N2O Filter, Blue
 BEP35505 1/4" - #6 N2O Fuel Filter, Red



SILICONE HOSE COUPLERS

- These silicone connectors are an easy way to plumb any of your air intake projects from supercharger systems to turbo systems and air intake systems.
- Manufactured from a minimum 0.170 wall multi-layer silicone with a polyester weave for added strength and features with an operating range from -65°F to 350°F.



Straight Couplers, 3" Long
 BEP38000 2" ID
 BEP38001 2.25" ID
 BEP38002 2.5" ID
 BEP38003 2.75" ID
 BEP38004 3" ID
 BEP38006 3.5" ID
 BEP38008 4" ID



90° Elbow Hose Couplers
 BEP38300 2.00" ID 90°
 BEP38301 2.25" ID 90°
 BEP38302 2.5" ID 90°
 BEP38303 3" ID 90°
 BEP38304 3.5" ID 90°
 BEP38305 4" ID 90°



45° Elbow Hose Couplers
 BEP38200 2.00" ID 45°
 BEP38201 2.25" ID 45°
 BEP38202 2.5" ID 45°
 BEP38203 3" ID 45°
 BEP38204 3.5" ID 45°
 BEP38205 4" ID 45°



Straight Transition Hose Couplers
 BEP38400 2.5 - 2 Reducer ID
 BEP38401 2.5 - 2.25 Reducer ID
 BEP38402 2.75 - 2.5 Reducer ID
 BEP38403 3" - 2" Reducer ID
 BEP38405 3" - 2.5" Reducer ID
 BEP38406 3" - 2.75" Reducer ID
 BEP38408 3.5" - 3" Reducer ID
 BEP38410 4" - 3" Reducer ID

Straight Hump Hose Couplers w/ Dual Stainless Rings 4" Long
 BEP38100 2" ID
 BEP38102 2.5" ID
 BEP38103 2.75" ID
 BEP38104 3" ID
 BEP38106 3.5" ID

90° Transition Couplers
 BEP38500 2.5" to 2.0" ID
 BEP38503 3.0" to 2.5" ID
 BEP38505 3.5" to 3.0" ID

SUPER COMP TACHOMETERS & GAUGES

- All have chrome bezels and includes a silver aluminum trim ring that snaps onto the bezel.
- Mechanical gauges feature bronze bourdon tube movement for accuracy and durability and a wide 270° sweep for quick, precise readings and they include proper tubing, adapter fittings & hardware.
- Electrical voltmeter feature an 80° sweep and does not include wiring.
- Tachometers feature peak RPM recall, a 270° full-sweep stepper motor, and have intense white through dial LED lighting.



BEP15215 Tach, 5" 0-10,000, White Face
BEP15216 Tach, 5" 0-10,000, White Face w/ Shift Light

BEP15205 Tach, 5" 0-10,000 Black Face
BEP15206 Tach, 5" 0-10,000 Black Face w/ Shift Light

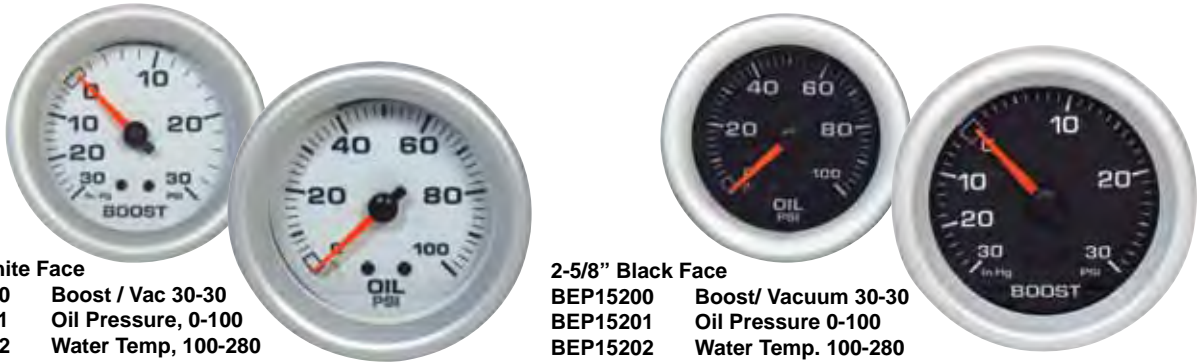

2-5/8" White Face

BEP15210 Boost / Vac 30-30
BEP15211 Oil Pressure, 0-100
BEP15212 Water Temp, 100-280
BEP15213 Oil Temp, 100-280
BEP15214 Volts, 8-18V

2-5/8" Black Face

BEP15200 Boost/ Vacuum 30-30
BEP15201 Oil Pressure 0-100
BEP15202 Water Temp. 100-280
BEP15203 Oil Temp. 100-280
BEP15204 Volts 8-18V

TACHOMETER WITH SHIFT LIGHT

- Adjustable shift point indicator sets shift light
- 3-1/2" Chrome bezel; Black housing with backlit dial
- Used with conventional or electronic ignition system (except MSD or C.D. ign. systems)
- For use in 4,6 or 8 cylinder engines

BEP15000 0-8,000 RPM
Shift Light Tach



TACHOMETERS

- Adjustable center dial on face to set shift point indicator
- 3-1/2" Chrome bezel w/black housing with backlit dial
- Used with conventional or electronic ign. system (except MSD or C.D. ign. systems)
- For use in 4,6 or 8 cylinder engines

BEP15001 0-8,000 RPM Tachometer, Black Face with White Numbers
BEP15002 0-8,000 RPM Tachometer, White Face with Black Numbers

CARBON FIBER LOOK PRESSURE GAUGES

- Stainless steel case
- Brass internals
- Silicone-filled
- 1/8" centered male NPT back mount

- BEP15045 0-15 PSI**
- BEP15046 0-30 PSI**
- BEP15047 0-60 PSI**
- BEP15048 0-100 PSI**

NEW!



MIDNIGHT BLACK PRESSURE GAUGES

- Stainless steel case
- Brass internals
- Silicone-filled
- 1/8" centered male NPT back mount

- BEP15016 0-15 PSI**
- BEP15017 0-30 PSI**
- BEP15018 0-60 PSI**
- BEP15019 0-100 PSI**

NEW!



PRESSURE GAUGES

- Chrome 1-1/2" diameter gauge
- Black face, white numbers
- Brass internals for long life
- 1/8" centered male NPT back mount

- BEP15026 0-15 PSI**
- BEP15027 0-30 PSI**
- BEP15028 0-60 PSI**
- BEP15029 0-100 PSI**



LIQUID FILLED PRESSURE GAUGES

- Chrome 1-1/2" dia. gauge
- Black face, white numbers
- Glycerin filled vibration protection
- 1/8" centered male N.P.T mount

- BEP15020 0-15 PSI**
- BEP15021 0-30 PSI**
- BEP15022 0-60 PSI**
- BEP15023 0-100 PSI**



LIQUID FILLED PRESSURE GAUGES

- Chrome 1-1/2" diameter gauge
- White face with black numbers
- Glycerin filled for vibration protection
- 1/8" centered male NPT mount

- BEP15030 0-15 PSI**
- BEP15031 0-30 PSI**
- BEP15032 0-60 PSI**
- BEP15033 0-100 PSI**



LIQUID FILLED NITROUS PRESSURE GAUGES

- Chrome 1-1/2" diameter gauge
- Available in black face or comp white
- Monitors bottle pressure, either on bottle or solenoid
- Glycerin filled for vibration protection
- 1/8" centered male NPT back mount

- BEP15024 0-1500 PSI Black / Yellow Dial**
- BEP15025 0-1500 PSI Midnight Black **NEW!****
- BEP15034 0-1500 PSI Comp White**



2 5/8" DIAMETER GAUGES

- 2-5/8" large diameter, race styling for street performance
- Features full sweep dial with black face, white pointer and race-style chrome bezel
- mechanical gauges
- All gauges come complete with adapters, tubing, light kit, mounting hardware and instructions



- BEP15051** Voltmeter 10-18 Volt
- BEP15052** Fuel Pressure 0-15 PSI
- BEP15053** Oil Pressure 0-100 PSI
- BEP15054** Oil Temperature 100°- 340° F
- BEP15055** Vacuum 0-30 HG
- BEP15056** Water Temperature 100°- 280°F

ENGINE-TURNED PRESSURE GAUGES

- Chrome 1-1/2" diameter gauge
- Machined, engine-turned dial with black pointer
- Glycerin filled for vibration protection
- 1/8" centered male N.P.T back mount



- BEP15040** 0-15 PSI
- BEP15041** 0-30 PSI
- BEP15042** 0-60 PSI
- BEP15043** 0-100 PSI

MULTI COLOR CONTROL TRIO GAUGE PANEL

- Gauges are 2 1/16" with brushed aluminum bezels mounted in a chrome panel
- Installation hardware included
- Select from 7 different colors



- BEP15083** Trio Panel, Mechanical, Water Temp, Oil Pressure and Voltmeter

2-5/8" CHROME GAUGE PANEL KITS

- Feature a large 2 5/8" full sweep dial with black face, white pointer and chrome bezel in a chrome plated mounting panel.
- All gauge panels come complete with adapters, tubing kit, light kit, mounting hardware and instructions.

- BEP15090** Dual Panel: Water Temp/ Oil Pressure
- BEP15091** Trio Panel: Water Temp/ Oil Pressure/Ammeter



2" GAUGE TRIO PANEL KITS

- Feature 2" dia. mechanical gauges fully assembled in a panel
- All gauge sets include adapters, mounting hardware, light kit and instructions

- BEP15080** Chrome Trio Gauges, Water/Oil/Amp
- BEP15081** Black Trio Gauges, Water/Oil/Amp
- BEP15082** Black Trio Gauges, Water/Oil/Volt

2-5/8" GAUGE PANELS & MOUNTING CUP

- Chrome plated

- BEP15100** Single Gauge Panel
- BEP15101** Dual Gauge Panel
- BEP15102** Triple Gauge Panel
- BEP15110** Single Gauge Mounting Cup



GAUGE SUPPLY LINE KITS

- Comes with all necessary fittings
- Line rated to 3,000 psi
- Stainless steel braided hose

- BEP15120** #4 Line Kit 36"
- BEP15121** #4 Line Kit 48"
- BEP15122** #4 Line Kit 72"



OIL PRESSURE GAUGE INSTALLATION KIT

- Includes 72" 1/8" nylon line and fittings

- BEP15105** Oil Pressure Gauge Install Kit



LIQUID FILLED ENGINE THERMOMETER

- Chrome 2" diameter gauge, can be mounted on an intake manifold or cylinder head for direct reading
- Glycerin filled for vibration protection
- Attaches to a 3/8" NPT fitting



- BEP15015** 0°-250° F Engine Thermometer

DIAL-IN MARKERS

- Dry bright and wipe off easily with a dry rag.
- Won't stain, so they can be used on painted surfaces, tires, and even on Lexan windows.

- BEP29600** White, 3oz.
- BEP29605** Yellow, 3oz.
- BEP29610** Orange, 3oz.
- BEP29620** White, 1 oz.
- BEP29625** Yellow, 1 oz.
- BEP29630** Orange, 1 oz.



ROLL BAR PADDING

- Made of special closed cell foam
- Absorbs shock to prevent driver injury
- Fits 1.50" to 1.75" diameter tubing
- Flame retardant.
- Not SFI approved

- BEP27000** Black
- BEP27001** Red
- BEP27002** Blue
- BEP27003** Yellow
- BEP27004** Orange
- BEP27005** Purple
- BEP27006** Gray



DIAL-IN BOARDS

- ET dial-in boards are perfect to replace that messy shoe polish or vinyl cling numbers.
- They feature pivoting numeral sections that allow you to adjust the dial-in quickly and easily.



- BEP29500** 4 Digit Velcro Mount & Suction Cups
- BEP29501** 4 Digit w/ Mounting Holes
- BEP29502** 3 Digit w/ Mounting Holes



- SFI ROLL BAR PADDING**
- High impact, high density.
 - 3 feet long sections, 1" thick
 - Shaped to fit 1.50" to 1.75"
 - SFI 45.1 approved



- BEP27020** Black
- BEP27025** New-Style Lo-Profile

RACER'S TAPE

- Multi-purpose colored duct tape.
- 2" x 180" Rolls. Comes in 7 colors.
- Tears straight and easy.



- BEP27100** Red
- BEP27101** Blue
- BEP27102** Yellow
- BEP27103** Black
- BEP27104** Silver
- BEP27105** White
- BEP27107** Orange



PRO-STYLE POLY HIGH BACK RACE SEATS

- Features 9.5" x 12" wide base with 3/8" (6) threaded inserts for mounting
- 21" w outside, 17" w inside, 4.5" seatbelt slots. 33" High back design
- 16" shoulder support back.
- Provision for seat-back braces



- BEP25300** Pro-Style High Back Seat
- BEP25150** Black Seat Cover



SEAT RISER BRACKET KIT

- Give you an extra inch of clearance
- Black power coated

BEP25002 Riser Bracket

SLIDER SEAT TRACK KIT

- Easy fore and aft adjustment
- Double locking rails.
- Zinc plated heavy duty steel construction



BEP25001 Adjustable Slider Seat Track Kit

UNDER BODY WASHERS

- 3/8" Dia. bolt mounting hole centered in the washer



BEP25000 Under Body Washer, 4pk.



POLY HIGH BACK RACE SEATS

- Made of double wall impact-absorbing polymer plastic
- Features 9.5" x 12" wide base with internal threaded inserts that bolt to seat brackets
- 21" wide outside with a 2" deep bucket for more head room and wide seat belt slots
- 33" High back design with a single slot for "V" style harnesses
- 17" W shoulder width



- BEP25100** High Back Seat
- BEP25350** Black Pro-Style Seat Cover



PANEL FASTENER SPRINGS

- These stout springs anchor the whole fastening system
- To be used with all panel and self-eject fasteners
- Packaged in quantities of ten



HIGH QUALITY PRODUCTS
PRICED RIGHT!

**BIG END
MEANS BIG VALUE!**

1" Hole Spacing		1-3/8" Hole Spacing	
BEP26374	.200 Height	BEP26400	.325 Height
BEP26382	.325 Height	BEP26406	.375 Height
		BEP26412	.425 Height

STEEL WELD FASTENER PLATES

- Fastener weld plates can be welded to any member of the vehicle to provide a pop rivet mount for fastener springs
- Many styles to choose for the best fabrication
- Packaged in quantities of ten

Part #	Pic.	Description
BEP26440	(A)	5/16" w/ 1" Spring
BEP26447	(B)	5/16" w/ 1" Spring
BEP26450	(C)	5/16" Self-Eject w/ 1" Spring
BEP26454	(D)	5/16" Self-Eject w/ 1" Spring
BEP26468	(E)	7/16" w/ 1-3/8" Spring
BEP26476	(F)	7/16" w/ 1-3/8" Spring
BEP26483	(G)	7/16" w/ 1-3/8" Spring
BEP26486	(H)	7/16" w/ 1-3/8" Spring
BEP26489	(J)	7/16" w/ 1-3/8" Spring, Corner Mount

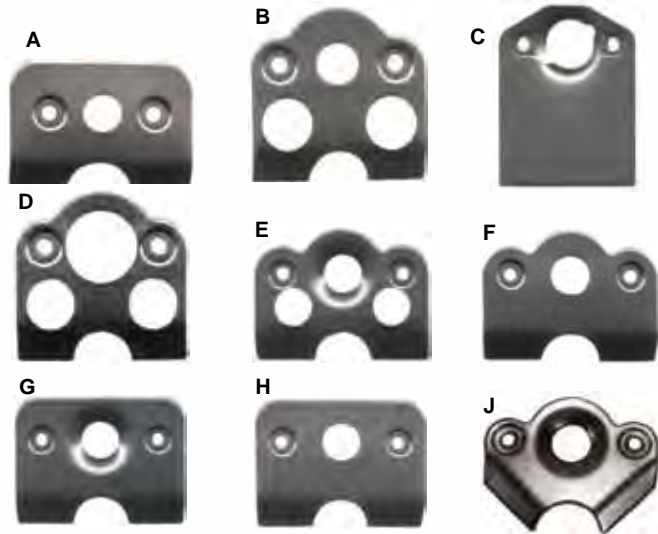

**QUARTER-TURN
BUTTON WRENCH**



BEP41041 Quarter Turn Button Wrench

PANEL FASTENERS

- Quick-turn cadmium plated fasteners used for all interior and exterior body panels
- Available in 4 body lengths and 3 head styles
- Packaged in quantities of ten

5/16" Steel Fasteners

BEP26200	Oval Head .400" Short Body
BEP26205	Oval Head .500" Medium Body

7/16" Steel Fasteners

BEP26225	Oval Head .500" Medium Body
BEP26231	Oval Head .550" Long Body
BEP26270	Flush Head .400" Short Body
BEP26274	Flush Head .450" Short Body
BEP26278	Flush Head .500" Medium Body
BEP26281	Flush Head .550" Long Body

7/16" Winged

BEP26130	Winged Head .500" Medium Body
BEP26133	Winged Head .550" Long Body



SELF-EJECT PANEL FASTENERS

- Quick-turn cadmium plated fasteners used on steel, aluminum, and fiberglass body and interior panels
- Load force is distributed more evenly to prevent pull-through
- Spring-loaded fastener snaps out easily
- Packaged in quantities of ten

5/16" Flush Head

BEP26320	.400 Short Body
BEP26324	.450 Short Body
BEP26327	.500 Medium Body
BEP26330	.550 Long Body



5/16" Winged

BEP26100	.500 Medium Body
BEP26103	.550 Long Body
BEP26106	.600 Long Body
BEP26109	.650 Extra Long Body



7/16" Flush Head

BEP26340	.500 Medium Body
BEP26346	.550 Long Body

FASTENER TECHNICAL INFORMATION

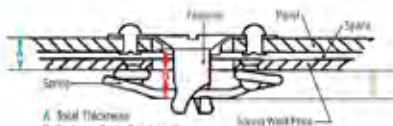

Determine the total thickness of panel being joined **A** including any space between panels.
Then specify the fastener grip length **B** and fastener spring height **C**.
The combination will provide the desired thickness range on chart.

Button Grip Length B :	.400	.450	.500	.550	.600	.650
1" Spring						
Spring Height :	Spring Part #			Total Thickness A		
.250"	# 26374	.225-.258	.273-.308	.323-.356	.373-.408	.425-.458
.325"	# 26382	.098-.133	.148-.183	.198-.233	.248-.283	.298-.333
						.348-.383
1-3/8" Spring						
.325"	# 26400	.105-.148	.155-.198	.205-.248	.255-.298	.305-.348
.375"	# 26406	.055-.098	.105-.148	.155-.198	.205-.248	.255-.298
.425"	# 26412	.005-.048	.055-.098	.105-.148	.155-.198	.205-.248
						.255-.298

Button Grip Length is the measurement from the bottom of head to the bottom of spring locking area on fastener

BRACKETS & TABS

- Designed for wide range of fabricating applications
- Weld-On style; Packaged in different quantities



BRAKES TABS

- BEP28114 Brake Line Tab, 5/8" Hole, .100" Steel, 3/4" Bottom to Center Hole, 4 Pk.
- BEP28116 Brake Tab, 1/8" Steel, 5/16" Hole, 1-1/4", 4 Pk.

CHANNEL FUEL CELL MOUNTING BRACKETS

- BEP28118 Channeled Fuel Cell, 1-3/8" W, 4-3/4" L, .085" Steel, 3/8" Hole, 1 Pk.
- BEP28120 Channeled Fuel Cell, 1-3/8" W, 2" L, .085" Steel, 3/8" Hole, 1 Pk.

ENGINE

- BEP28124 Engine Stand Tab, 3/8" Steel, 1-3/8" L, 3/8" Hole, 1 Pk.
- BEP28130 Transmission Mounting Bracket, 1/8" Steel, 1"x7/16" Slot, 1 Pk.
- BEP28134 Radiator Support Bracket, 3" Wide, 3/16" Hole, 1 Pk.
- BEP28138 Header Tab, .085" Steel, 1/4" Hole, Pieces with Nuts and Bolts.

- BEP28140 Remote Oil Filter Mounting 1/8" Steel 5/16" holes

FRONT SUSPENSION

- BEP28144 A-arm Plate 3/8" Steel 1/2" Hole
- BEP28146 A-arm Shim 1/6" Steel 10 Pk.
- BEP28148 A-arm Shim 1/8" Steel 10 Pk.
- BEP28152 A-Arm Mounts, 3/16" Steel, Fit 1-1/2" Tubing, 1/2" Hole, 1 Pk.

- BEP28172 Rack & Pinion Mounting Bracket, Pinto

FUEL

- BEP28128 Fuel Pump Mount, 1/8" Steel, 11/32" Hole, 3" Center Between Holes, 1 Pk.

GUSSETS

- BEP28102 Std, 1/8" Steel Gusset, 1-7/8" L, 1/2" Hole, 100 Pk.
- BEP28104 Std, 1/8" Steel Gusset, 1-7/8" L, No Hole, 100 Pk.
- BEP28110 Mini Gusset, 1/8" Steel, 2" L, 1-1/2" Side Length, 1 Pk.
- BEP28100 3 Hole Gusset, 1/8" Steel, 1-3/4" Side Length, 100 Pk.

SHOCK SPACER MOUNTS

- BEP28160 Spacer Bushing, 1/2" Hole, 7/8" Long, Coil Over Mount, 1 Pk.
- BEP28162 Spacer Bushing, 1/2" Hole, 1/2" Long, Coil Over Mount, 1 Pk.

SHOCK MOUNTS

- BEP28168 Lower Control Arm Shock Mount, 1/2" Weld Bushing, 1-1/16" Gap, 1 Pk.

FRAME SUPPORT TABS

- BEP28174 Round Support, 1-1/4" Dia. , 1/8" Steel, 1 Pk.
- BEP28176 Round Support, 1-1/2" Dia. , 1/8" Steel, 1 Pk.
- BEP28178 Round Support, 1-3/4" Dia. , 1/8" Steel, 1 Pk.

BODY TABS

- BEP28184 Body Tab, .085" Steel, 1/4" Hole, 1 Pk.
- BEP28186 Body Tab, .085" Steel, 3/8" Hole, 1 Pk.
- BEP28188 Body Tab, .085" Steel, 1/4" Hole, Flat, 1 Pk.



BRACKETS & TABS, CONTINUED



CHASSIS TABS

- BEP28190 Chassis Tab, 3/16" Steel, 1/2" Hole, 1-3/4" Center to Edge, 1-1/2" Tubing, 1 Pkg.
- BEP28200 Chassis Tab, 3/16" Steel, 3/8" Hole, 1-1/4" from Center to Flat, 1 Pkg.
- BEP28202 Chassis Tab, 3/16" Steel, 1/2" Hole, 1-3/8" from Center to Flat, 1 Pkg.
- BEP28204 Chassis Tab, 1/8" Steel, 1/2" Hole, 1-3/8" from Center to Flat, 1 Pkg.
- BEP28206 H.D. Chassis Tab, 1/4" Steel, 1/2" Hole, 1-3/8" from Center to Flat, 1 Pkg.
- BEP28260 Chassis Tab, 3/16" Steel, 3/8" Hole, 1" from Center to Flat, 1 Pkg.

SEAT MOUNTING TABS

- BEP28208 1/8" Steel, 1/2" Hole, 7/8" Center to Flat, 1 Pkg.
- BEP28210 3/16" Steel, 1/2" Hole, 7/8" Center to Flat, 1 Pkg.
- BEP28212 1/4" Steel, 1/2" Hole, 7/8" Center to Flat, 1 Pkg.

TRICK TABS

- BEP28214 Trick Tab, 1/8" Steel, 3/8" Hole, 1 Pkg.
- BEP28216 Trick Tab, 1/8" Steel, 1/2" Hole, 1 Pkg.
- BEP28218 Trick Tab, 1/8" Steel, 1/4" Hole, 1 Pkg.

WINDOW FRAME TABS

- BEP28220 Window Frame Tabs, 16 Ga. Steel, 3/16" Hole, 1" x 1" Steel, 1 Pkg.
- BEP28222 Window Frame Tabs, 16 Ga. Steel, 3/16" Hole, 3/4" x 3/4" Steel, 10 Pkg.

BODY TABS

- BEP28224 Body Tab, .085" Steel, 1/4" Hole, 1 Pkg.
- BEP28226 Body Tab, .085" Steel, 3/8" Hole, 1 Pkg.

SKIN TABS

- BEP28228 Skin Tab, 1/8" Steel, 3/16" Hole, 1 Pkg.

NINTEY DEGREE GUSSET TAB

- BEP28230 90° Gusset Tab, 1/8" Steel, 2" Long, Fits 1-1/2" Tubing, 3/8" Hole, 1 Pkg.

PARACHUTE TAB

- BEP28238 Parachute Tab, 1/8" Mild Steel, 3/8" Hole, 1-3/4" T, 1-1/8" Center to Flat, 1 Pkg.

RADIUS TABS

- BEP28232 1/8" Steel, Fits 1-1/4" Tubing, 1-1/2" Long, 1/4" Hole, 1 Pkg.
- BEP28234 1/8" Steel, Fits 1-1/4" Tubing, 1-1/2" Long, 3/8" Hole, 1 Pkg.
- BEP28244 1/8" Steel, Fits 1-1/4" Tubing, 1/4" Hole, 1 Pkg.
- BEP28246 1/8" Steel, Fits 1-1/4" Tubing, 3/8" Hole, 1 Pkg.
- BEP28258 3/16" Steel, Fits 1-3/4" Tubing, 1/2" Hole, 1" Center Radius, 1 Pkg.

BUMPER TAB

- BEP28250 Bumper Tab, 1/8" Steel, 1/4" Hole, 1-1/4" Long, 15/16" Center to Flat, 1 Pkg.

REAR WING TAB

- BEP28254 Rear Wing Mounting Tab, 1/8" Steel, 1/4" Hole, 1-7/16" L, 7/8" from Center, 1 Pkg.

RUB RAIL FLANGE

- BEP28256 Rub Rail Flange, 3/16" Steel, 1-1/4" Dia. Large Center Hole, 3/8" Small Holes, 2-1/4" Center to Center Between Holes.

WING TAB

- BEP28264 .046" Steel, Triangular w/ Three 3/16" Holes



HOOD PIN KIT

- Hair pin style
- 1/2" x 4" chrome plated post with adjusting nuts
- 1-1/2" chrome plated scuff plates, hairpin clip and sheet metal screws
- Ideal for sheet metal and fiberglass hoods



BEP26000 Hood Pin Kit

FLIP-OVER HOOD PIN KIT

- Torsion style
- 1/2" x 4" chrome-plated posts with adjusting nuts
- 1-1/2" scuff plates, flip-over safety pins, and sheet metal screws
- Ideal for sheet metal and fiberglass body hoods



BEP26005 Hood Pin Kit-Flip Over Style

REPLACEMENT PINS

- Replacement pins
- Sold each



BEP26010 Hair Pin
BEP26012 Flip Over, Torsion Style

LIGHTWEIGHT HOOD SPRINGS

- Lightweight hood springs for bolt on fiberglass hood replaces OEM
- Two styles of hood springs, sold each



BEP26030 Short Hood Springs
BEP26031 Long Hood Springs

HOOD PIN LANYARDS

- 24" Chrome-plated plastic coated cables
- 2/pkg.



BEP26025 Chrome Plastic Coated Lanyards

SCUFF PLATES

- Chrome plated metal
- Sold each



BEP26015 Scuff Plates

ALUMINUM EPOXY COATED RIVETS

- Aluminum Body with steel mandrel
- Holds body panels tightly together
- 1/4" to 3/8" grip
- 250 per package



3/16" Small Dome Rivets	3/16" Large Dome Rivets
BEP24002 Silver	BEP24020 Silver
BEP24004 White	BEP24022 White
BEP24006 Black	BEP24024 Black
BEP24008 Red	BEP24026 Red
BEP24010 Blue	BEP24028 Blue
BEP24012 Yellow	BEP24030 Yellow
BEP24014 Orange	BEP24032 Orange

1/8" Small Dome Rivets
BEP24042 Silver, .003"-.125" Grip
BEP24044 Silver, .188"-.250" Grip

CLECO PINS

- Cleco pins allow easy installation and removal of sheet metal panels during mock-up fitting
- Reuseable pins work up to 1/4"



BEP24080 1/8", 10 Qty.	BEP24083 3/16", 10 Qty.
BEP24081 1/8", 25 Qty.	BEP24084 3/16", 25 Qty.
BEP24082 1/8", 100 Qty.	BEP24085 3/16", 100 Qty.

CLECO PLIERS

- Used to install and remove Cleco pins



BEP24088 Cleco Pliers

TRI-FOLD RIVETS

- 3/16" flange diameter, .062" thick
- Tri-fold type design for a large secondary expansion



BEP24050 Tri-Fold Rivet, Silver, 250 Qty.

3/16" BACK-UP WASHERS

- Prevents pull-through and provides a secure fitment



BEP24060 1/2" Dia. Medium, 500 Qty.
BEP24062 5/8" Dia. Large, 500 Qty.

DOUBLE-END DRILL BITS

- For rivets



BEP24070 1/8" Drill Bit Each
BEP24071 3/16" Drill Bit Each



HIGH PERFORMANCE TORQUE CONVERTERS

- Big End HP High Performance Torque Converters are the best value and quality converter made today
- Every HP Torque Converter features furnace brazed and welded impeller and turbine ID & OD fins "tigged" (except BEP32000, 32002 and 32006) Torrington bearings used throughout the converter, heat treated drive hub on impeller assembly, "Modified Blade" aluminum stator design, billet steel turbine hub, and computer spin balanced
- All hubs, pads, splines, pilots, and bushings are parallel, perpendicular, and concentric to one another for a perfect fit and alignment, guaranteed
- All converters are factory tested for balance and pressure.

GM CONVERTERS

- Pump and turbine fins are tig spot welded for extra strength
- Rebuilt sprag assembly
- New pump hub
- Computer balanced



FORD CONVERTERS

- Highest quality on the market
- New bearings between the stator & pump, rebuilt sprag assembly
- New pump hub, new turbine hub
- Pump and turbine tig spot welded for extra strength
- Computer balanced, high pressure leak tested

MOPAR CONVERTERS

- New Torrington bearings between stator and pump
- Rebuilt sprag assembly
- New pump hub
- New turbine hub, computer balanced



FORD AOD TORQUE CONVERTERS

- Designed specifically for use with Ford automatic overdrive transmission
- Excellent performance and still retains the lockup feature
- Great choice for the 5.0L Mustang

C-4 H.D. TORQUE CONVERTERS

- Primarily for highly modified and street-driven vehicles
- Excellent for short stroke 289-302-351W engines
- Recommended for 4:10-5:13 rear end ratios
- Proudly made in the U.S.A.



XHD BIG NITROUS TORQUE CONVERTERS

- The Big End XHD (Extra Heavy-Duty) torque converter features additional ballooning control and a 360° drive flange
- Steel billet turbine hub, heat-treated and finish ground splines, internal and external anti-ballooning plates, and mounting ring for high horsepower applications exceeds 650.

TORQUE CONVERTER APPLICATION CHART

MOPAR / CHRYSLER	2400-2700 STALL	2500-3500 STALL			
'87-'81 Torqueflite 727 non lock-up 24 spline 10" bolt circle	BEP32008	BEP32005			
FORD AOD 2400-2800 STALL					
1980 - Later AOD 5.0L, 351W lock-up 11.4" bolt circle	BEP32012				
FORD C4 2000-2400 STALL 2200-2600 STALL 2900-3300 STALL					
1970 - Later C4 10.5" bolt circle 26 spline, dipstick goes into trans case. 1.375" pilot	BEP32007		BEP32110 H.D. CONVERTER		
1970 - Later C4 11.4" bolt circle 26 spline, dipstick goes into trans case. 1.375" pilot			BEP32105 H.D. CONVERTER		
FORD C6 2200-2600 STALL					
'71-'91 C6 11.4" bolt circle 289, 302, 351, 400 1.375" crank pilot	BEP32006				
GM TURBO-HYDROMATIC 1900-2400 STALL 2400-2800 STALL 2800-3200 STALL 3200-3500 STALL 3500-3800 STALL					
'85-'81 TH350, TH400 small bolt pattern (except lock-up)	BEP32002	BEP32000			
'85-'81 TH350, TH400 dual bolt pattern (except lock-up)			BEP32001 BEP32050 X.H.D. CONVERTER	BEP32003 BEP32055 X.H.D. CONVERTER	BEP32004 BEP32060 X.H.D. CONVERTER
GM TH700R4 2000-2400 STALL 2400-2800 STALL					
'84-'97 TH700R4 30 spline, lock-up dual bolt pattern (except LS1 / LS2)	BEP32016	BEP32017			

SFI FLEXPLATES

- SFI Approved for all racing classes in NHRA, or IHRA that require an SFI stickered flexplate
- 0.35" thicker than stock, double-welded ring gear
- Double drilled for large and small converter patterns
- All SFI flywheels are zinc plated for moisture resistance; SFI 29.1 approved

- BEP34000** SB/BB Chevy Int. Balanced 168T, 2 Pc. Rear Main 55-88
BEP34002 SB 400 Chevy Ext. Balanced 168T, 2 Pc. Rear Main 70-80
BEP34004 BB Chevy Ext. Balanced 168T, Up to 90
BEP34006 SB Chevy Int. Balanced 153T, 2 Pc. Rear Main Up-88
BEP34008 SB Chevy Ext. Balanced 168T, Late 1 Pc. Rear Main 89-98



OEM REPLACEMENT FLEXPLATES

- Big End Automatic OEM Flexplates are a direct replacement of the stock units
- Provides the same high quality performance as the original



- BEP34001** SB/BB Chevy Int. Balanced 168T 2Pc. Rear Main 55-88
BEP34003 SB Chevy 400 Ext. Balanced Rear Main 70-80
BEP34005 BB Chevy Ext. Balanced 168T 2 Pc. Rear Main, Up-90
BEP34007 SB Chevy Int. Balanced 153T 2Pc. Rear Main 55-88



REAR END GIRDLES

- All girdles are made of 356 aircraft grade aluminum, heat treated to T6 specifications, each cover is then stress relieved.
- Fill port and drain port for ease of servicing.
- Show a decrease in operating temperature, average of 15 degrees.
- Weigh about 9.5 lbs.
- Improves undercarriage appearance.



Ford		DANA	
BEP31805	7.5"	BEP31812	DANA 60
BEP31806	8.8"	BEP31813	DANA 70
GM		Cap Stud Kits	
BEP31807	10-Bolt, 8.5"	BEP31815	GM Kit
BEP31808	10-Bolt, B.O.P.	BEP31816	Ford / Dana Kit
BEP31809	10-Bolt, 7.5"		
BEP31810	12-Bolt, Car		
BEP31811	12-Bolt, Truck		

FULL LIGHTWEIGHT STEEL SPOOLS

- Manufactured from 4140 chrome-moly forgings
- Machined and lightened by state of the art CNC machinery to exact specifications
- Permanently locks both axles together to keep tires at same speed
- For all drag race & circle track applications

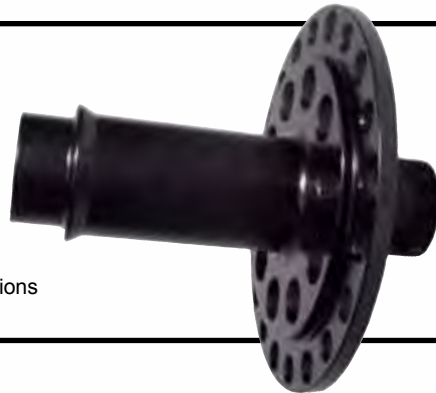

Ford 9"			
Part #	Bearing I.D.	Axle Spline	
BEP31001	3.062"	28	
BEP31003	3.062"	31	
BEP31006	3.250"	35	

GM 12, Bolt 3.90 and Up, 4-Series Carrier			
Part #	Bearing I.D.	Axle Spline	
BEP31000	Standard	30	

MINI SPOOLS

- Manufactured of 8620 non-leaded steel
- Replaces OEM spider gears in open carrier units, locking together both axles for even power to both tires used mostly in drag racing & dirt oval track
- Machined by the state of the art CNC machinery to exact specifications
- Fits open series carriers only
- GM 7.5 fits 3.08 and up carrier only

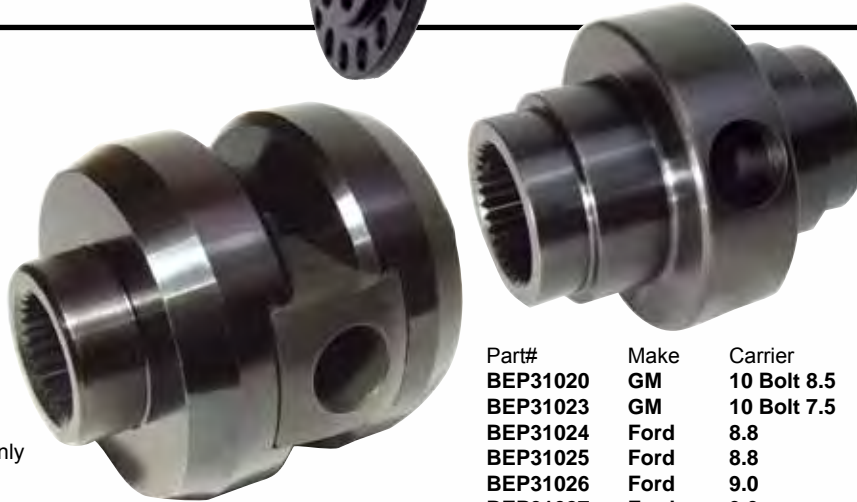

Part#	Make	Carrier	Spline
BEP31020	GM	10 Bolt 8.5	28
BEP31023	GM	10 Bolt 7.5	26
BEP31024	Ford	8.8	28
BEP31025	Ford	8.8	31
BEP31026	Ford	9.0	28
BEP31027	Ford	9.0	31

CROSS PIN

- Made of 4140 Chrome-moly steel
- A must when using mini spool in oval track applications



BEP31042 9 Inch Ford Cross Pin



RING GEAR SPACER

- Made of high quality steel
- Fits GM 7.5" 10 bolt differentials
- Includes Grade 8 bolts

BEP31030 Ring Gear Spacer Kit 7.5" GM

John Wiley's Henry J



BIG END
PERFORMANCE PRODUCTS
RACE TESTED & PROVEN!

RING AND PINION SETS

- Designed for street, moderate strip and circle track applications
- Forged steel is heat-treated for added strength and Rockwell tested for correct hardness
- Machined to the tightest tolerances in the industry

FORD 9" GEAR SETS

- Fits 62-87 Ford 9 inch, 11-3/4" oval housing
- 10 bolt ring gear
- 9.00" Ring gear diameter, 1.313" pinion diameter
- 28 spline pinion

	RATIO	TEETH
BEP30000	3.50	35-10
BEP30040	3.70	37-10
BEP30001	3.89	35-9
BEP30002	4.11	37-9
BEP30003	4.57	32-7
BEP30005	5.14	36-7
BEP30006	5.43	38-7
BEP30007	5.67	34-6
BEP30008	5.83	35-6
BEP30009	6.00	36-6
BEP30010	6.20	31-5
BEP30045	6.33	38-6
BEP30011	6.50	39-6



Mini Spool	Axle Spline
BEP31026	28
BEP31027	31

Installation Kit	
BEP30125	Open
BEP30127	3.062" Bearing

Lightweight Spool	
BEP31001	3.062" 28
BEP31003	3.062" 31
BEP31006	3.250" 35

Cross Pin	
BEP31042	Chrome Moly Cross Pin

FORD 8.8" GEAR SETS

- All V8 Ford Mustangs 85-Up Trucks
81-02, full size car 82-Up, T-Bird 87-97
- 10 bolt rear cover
 - 8.8" diameter ring gear
 - 1.626" pinion diameter
 - 30 spline pinion

	RATIO	TEETH
BEP30050	3.55	39-11
BEP30052	3.73	41-11
BEP30054	4.10	41-10



Mini Spools	Axle Spline
BEP31024	28
BEP31025	31

Installation Kit	
BEP30120	Ford 8.8" Gear

GM 7.5" GEAR SETS

- All GM Models, 77-02, 82-02 Camaro, Firebird,
83-02 S-10
- 8-5/16" x 10 9/16" oval cover, 10 bolt rear cover
 - 7.5" diameter ring gear fits most 7.5 and 7.625" applications
 - 1.438" pinion diameter, 27 spline

	RATIO	TEETH	CARRIER
BEP30026	3.42	41-12	3
BEP30012	3.73	41-11	3
BEP30014	4.10	41-10	3

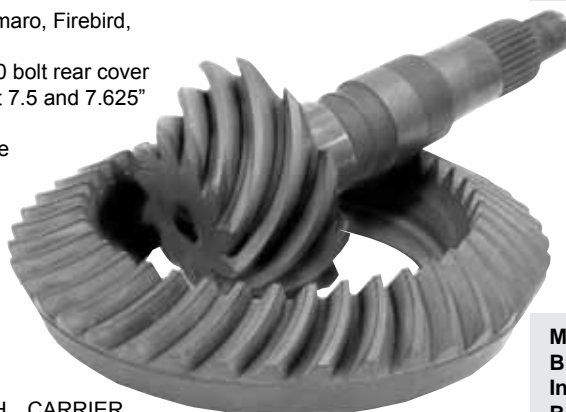

Mini Spool Axle Spline	
BEP31023	26
Installation Kit	
BEP30105	GM 10 Bolt, 7.5" Gear 80-96
	Ring Gear Spacer
BEP31030	Ring gear spacer kit 7.5" GM

GM 8.5" GEAR SETS

All GM 70-81, 77-02 All GM Trucks
(Check Ring Gear Size)

- (A)11" Irregular 10 bolt rear cover
- (B)10 5/8" Irregular 10 bolt rear cover
- 8.50" diameter ring gear
- 1.625" pinion diameter
- 30 spline pinion



Mini Spool Axle Spline
BEP31020 **28**
 Installation Kit
BEP30100 **GM 10 Bolt, 8.5" Gear 73-97**

	RATIO	TEETH	CARRIER
BEP30016	4.11	37-9	3
BEP30017	3.42	41-12	3
BEP30018	3.73	41-11	3
BEP30020	4.11	41-10	3
BEP30021	4.56	41-9	3

GM 8.875" CAR GEAR SETS

- All 12 Bolt Passenger Cars 65-72
- 10-7/8" Oval 12 bolt rear cover
 - 8.875" diameter ring gear, 1.625" diameter, 30 spline pinion



Lightweight Steel Spool Axle Spline
BEP31000 **30**

Installation Kit
BEP30115 **GM 12 Bolt, 8.875" Gear Auto**



	RATIO	TEETH	CARRIER
BEP30027	3.42	41-12	3
BEP30022	3.73	41-11	3
BEP30024	4.10	37-9	4
BEP30025	4.56	41-9	4

SEE PAGE 64 FOR THE
GEAR / RATIO SELECTION CHART

COMPLETE INSTALLATION KITS

- Complete with Timken® bearings
- Kit Includes: Pinion and carrier bearings, pinion nut and washer, pinion seal, pinion and carrier shims, crush sleeve, ring gear bolts and washers, marking compound and brush, silicone sealer and red thread locker
- Ford 9" includes pilot bearings

BEARINGS
MANUFACTURED BY:
TIMKEN



PASSENGER CAR

- BEP30100** **GM 10 Bolt, 8.5" Gear 73-97**
- BEP30105** **GM 10 Bolt, 7.5" Gear 80-96**
- BEP30117** **GM 10 Bolt, 8.2" Gear Chevy 64-71**
- BEP30130** **GM 10 Bolt, 8.2" B.O.P 64-71**
- BEP30115** **GM 12 Bolt, 8.875" Gear Auto**
- BEP30120** **Ford 8.8" Gear**
- BEP30125** **Ford 9" Open, 2.891" Bearing**
- BEP30127** **Ford 9" 3.062" Bearing w/Solid Pinion Spacer (No Crush Sleeve)**

TRUCK

- BEP30100** **GM 10 Bolt, 8.5" Gear C & K 1/2 Ton 73-97**
- BEP30105** **GM 10 Bolt, 7.5" 7.625" Gear S-10, S-15 82-92**
- BEP30120** **Ford 8.8" Gear 1/2 Ton Trucks, Vans 83-90**
- BEP30125** **Ford 9" Open 1/2 Ton Trucks 71-88, 2.891" Bearing**
- BEP30127** **Ford 9" 3.062" Bearing 1/2 Ton Trucks 57-70 w/ Solid Pinion Spacer (No Crush Sleeve)**

HIGH QUALITY PRODUCTS
PRICED RIGHT!

BIG END
MEANS BIG VALUE!

STAINLESS STEEL BRAKE LINES

- Each line is constructed from smooth bore PTFE tube reinforced with a 308 stainless steel braided cover, allowing a firmer and faster brake pedal response
- 3 AN lines conform to DOT specs
- Both -3 and -4 are available in both straight/ straight, or straight/ 90 degree hose end configurations



		Straight /Straight	
		BEP21209	#4, 9"
		BEP21212	#4, 12"
		BEP21215	#4, 15"
		BEP21218	#4, 18"
		BEP21221	#4, 21"
		BEP21224	#4, 24"
		BEP21230	#4, 30"
		BEP21236	#4, 36"
		BEP21242	#4, 42"
		BEP21248	#4, 48"
		Straight /90 Degrees	
		BEP21109	#3, 9"
		BEP21112	#3, 12"
		BEP21115	#3, 15"
		BEP21118	#3, 18"
		BEP21120	#3, 20"
		BEP21124	#3, 24"
		BEP21130	#3, 30"
		BEP21136	#3, 36"
		BEP21142	#3, 42"

BRAKE ADAPTER FITTINGS

- 3AN to Pipe Adapters. Sold each
- BEP22000** 1/8" to #3 Straight
- BEP22001** 1/8" to #3 45 Degree
- BEP22002** 1/8" to #3 90 Degree



- AN to Inverted Flare Adapter
- BEP22020** #3 to 3/8"-24, 2Pk Male
- BEP22021** #3 to 7/16"-24, 2Pk
- BEP22022** #3 to 7/16"-20, 2Pk
- BEP22025** #4 to 3/8"-24, 2Pk
- BEP22030** #3 to 3/8"-24, 2Pk Female



- 3AN Banjo Adapters. Sold each
- BEP22010** 10MM Straight to #3
- BEP22011** 10MM 35 Degree to #3
- BEP22012** 10MM 90 Degree to #3



- AN Flare Short Banjo Adapter
- BEP22040** #3 TO 10MM
- BEP22041** #4 TO 10MM



- Banjo Bolts
- BEP22070** 10MM X 1.25
- BEP22071** 10MM X 1.00
- BEP22072** 10MM X 1.50



- 3 AN Flare Tee
- BEP22050** #3 AN Flare Tee

- Aluminum Crush Washers
- BEP22060** 10MM, 10 Pack
- BEP22061** 7/16", 10 Pack



BILLET WHEELIE-BAR WHEELS

- Made from solid billet 6061-T6 aircraft grade material
- Molded with a polyurethane material that won't dent or give like a rubber wheel can.
- Over a 10,000 lbs/ft. load capacity
- 4" O.D., 3/8" through hole for mounting.
- Track tested over 4 years & run on vehicles making over 1500HP.



- BEP29100** Star Style Wheels
- BEP29105** Hole Style Wheels



ADJUSTABLE PROPORTIONING VALVE

- Adjustable braking percentages
- Billet anodized black aluminum
- Easy finger-grip knob
- 1/8" Female pipe ports
- Includes inverted flare adapters

- BEP20000** Adjustable Proportioning Valve



RESIDUAL VALVES

- Retain minimal fluid pressure by preventing drain back in the brake lines in applications where the master cylinder is located below the calipers.
- 2 pound residual brake pressure valve is designed for disc brakes while the 10 pound valve is used for drum brakes.



- BEP20010** 2 lbs, Blue
- BEP20012** 10 lbs, Red

PROPORTIONING VALVES

- Fixed designed after factory style valves.
- Perfect for conversions from drum to disc brakes

- BEP20005** Disc/Disc, Brass
- BEP20007** Disc/Drum, Brass

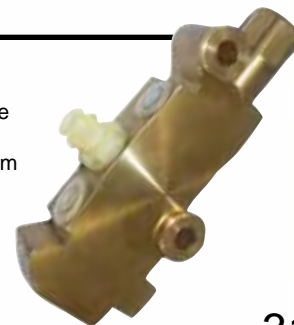

WHEEL VALVE STEMS & CAPS

- Chrome-plated and quality finish adds the classic look to mag wheels
- Pull through or bolt-in styles
- Chrome caps included or sold separately
- 2/Package



BEP20200 Bolt-In Chrome Valve Stem
BEP20201 Pull-Thru Chrome Valve Stem
BEP20220 Chrome Valve Stem Cap (4 per bag)

TIRE PRESSURE GAUGES

- 2-5/8" diameter dial
- Protective rubber bezel
- 13mm hose w/ air check valve

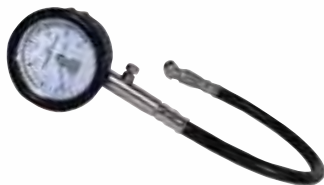

BEP15151 0-15 PSI
BEP15152 0-30 PSI
BEP15153 0-60 PSI

ALUMINUM WHEEL SPACERS

- Universal 3/8" thick die-cast aluminum
- 5-Hole 4-1/2, 4-3/4, 5" bolt circles
- 2/Package



BEP20110 Disc Brake Spacers 3/8" Thick (Pair)

WHEEL RIM SCREWS

- Grade 8 quality, self-tapping screws
- Anchors tire on rim, prevents spinning
- Built-in washer face
- Uses a 3/8" hex socket driver
- 35/Package

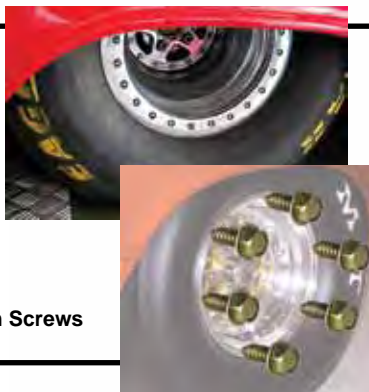

BEP65200 Wheel Rim Screws

BILLET LINE CLAMPS

- Secure and dress up your lines, cables, or wiring with our 2-piece billet line clamps.
- Designed to securely hold all of your wiring and hardline and allow you to bolt them directly to the frame or firewall.



BEP22100 3/16", 4 PK **BEP22102 5/16", 4 PK**
BEP22101 1/4", 4 PK **BEP22103 3/8", 4 PK**

DRAG RACE WHEEL STUDS

- Manufactured from high quality material with shears loads that are greater than Grade 8 specs
- For use in drag racing applications where one inch or thicker wheel is used, and rules require an exposed wheel stud past lug nut
- Press-in wheel studs feature strong knurls for press fit; quick start end for easy lug nut installation
- 5/Package



BEP20360 7/16"-20 x 3" Long, .480" Dia. Knurl, Late GM Drum Brake, Applications Hole Size .472"-.479", Quick Start End, 5/PKG.
BEP20362 7/16"-20 x 3" Long, .560" Dia. Knurl, Late GM Applications, Hole Size .552"-.559", Quick Start End, 5/PKG.
BEP20364 1/2"-20 x 3" Long, .615" Dia. Knurl, Ford Disc Brake and Mopar Front, Applications Hole Size .606"-.613", Quick Start End, 5/PKG.
BEP20366 1/2"-20 x 3" Long, .685" Dia. Knurl, Chrysler B, E Body Rear with 1/2" Studs, Applications Hole Size .676"-.683", Quick Start End, 5/PKG.
BEP20372 1/2"-20 x 3" Long, Screw-in, Fits all Aftermarket Axles with 1/2"-20 Threads, 5/PKG.

DRIVESHAFT SAFETY LOOP

- Made of heavy-gauge steel; Fully adjustable
- Universal mounting, hardware included
- Zinc-plated for rust prevention

BEP28000 Driveshaft Safety Loop



CIRCLE TRACK WHEEL STUDS

- Manufactured from high-grade steel; shears / loads greater than Grade 8 specs
- For use in Circle track applications where one inch or thicker wheel is used, and rules require an exposed wheel stud past lug nut
- Press-in wheel studs feature strong knurls for press fit; sold each



BEP20320 5/8"-11 x 2-3/4" Long, .690" Knurl, .850 Shoulder Length, Coarse Threads, Oval Track Use, Quick Start End, 1/PKG.
BEP20322 5/8"-11 x 2-3/4" Long, .690" Knurl, .375 Shoulder Length, Coarse Threads, Oval Track Use, Quick Start End, 1/PKG.

FUEL FRAGRANCES

- Eliminates unpleasant exhaust fumes and the eye, nose, and throat irritation that comes from your alcohol or gasoline fueled vehicle. Just mix it in with your fuel one 4 oz. bottle will treat 30 gallons of alcohol or 20 gallons of gas.

- | | | | |
|----------|------------|----------|----------------|
| BEP17119 | Cherry | BEP17145 | Root Beer |
| BEP17132 | Grape | BEP17146 | Hawaiian Punch |
| BEP17136 | Strawberry | BEP17147 | Pina Colada |
| BEP17139 | Cinnamon | BEP17148 | Watermelon |
| BEP17141 | Raspberry | BEP17149 | Cotton Candy |
| BEP17142 | Banana | BEP17150 | Apple |
| BEP17143 | Vanilla | BEP17152 | Blueberry |
| BEP17144 | Bubble Gum | BEP17153 | Tangerine |
| | | BEP17171 | Reefer |
| | | | Madness |

MANUFACTURED BY:
POWER PLUS



POWER PLUS LUBE

- Eliminates cylinder washdown and excessive wear.
- Mix it in with your fuel one 16 oz. bottle treats up to 55 gallons

- | | |
|----------|------------------|
| BEP17018 | Cherry |
| BEP17031 | Grape |
| BEP17035 | Strawberry |
| BEP17037 | Unscented, Clear |
| BEP17038 | Unscented, Blue |

MANUFACTURED BY:
POWER PLUS



HOT LAP TIRE SOFTENERS

- Reduces lap times 2-5 tenths, corner speeds increase 3-5 mph.
- Increases tire life up to 50%
- Victory Lap traction treatment is detectable.

- | | |
|----------|--------------------------|
| BEP20420 | Victory Lap, 1 Gal. |
| BEP20425 | Hot Lap II, 1 Gal. |
| BEP20430 | Hot Lap Pro Bite, 32 oz. |

MANUFACTURED BY:
Hot Lap



WHEELIE BAR CHALK

- Designed to leave bright solid marks on the track, to help tune your chassis to perfection.
- Feature a special applicator that ensures the correct amount is applied to each wheel.

- | | |
|----------|--------|
| BEP29210 | White |
| BEP29215 | Yellow |
| BEP29220 | Orange |

MANUFACTURED BY:
Clear One



MANUFACTURED BY:
PJ1

TRACKBITE

- Custom formulated resin that provides controlled traction for competition racing.
- Liquid track and tire treatment, which improves traction on asphalt and concrete surfaces.

- | | |
|----------|-------------------|
| BEP20400 | TrackBite, 1 Gal. |
|----------|-------------------|



ENGINE RACING FORMULA

- Add to severe duty, high stress and performance engines.
- Cools oil up to 57 degrees. Eliminates oil starvation, bearing failure, piston scuffing, and more!

- | | |
|----------|-----------------------|
| BEP43500 | Engine Racing Formula |
|----------|-----------------------|

MANUFACTURED BY:
Hot Lap



SPRAY WHEELY BAR CHALK

- Unique, easy to clean aerosol coating
- Wheelie Bar Chalk was developed to replace messy and hard to clean shoe polish.

- | | |
|----------|-------|
| BEP29200 | White |
|----------|-------|

MANUFACTURED BY:
PJ1



40 BELOW

- Prevents coolant temperature from rising excessively while vehicle is towing, climbing, sitting in traffic, or running with restricted air flow.

- | | |
|----------|---------------------------|
| BEP60700 | 40-Below Coolant Additive |
|----------|---------------------------|

MANUFACTURED BY:
Hot Lap

HIGH QUALITY PRODUCTS
PRICED RIGHT!

BIG END
MEANS BIG VALUE!



SMALL BLOCK CHEVY STREET/STRIP OIL PANS

- 7 Quart capacity with kick-out sump
- Painted, stamped steel with a welded wide base provides additional ground clearance
- Fit most GM chassis (ex 62-67 Chevy II V-8 Monza/Vega)
- Sump size: 8-1/4" from pan rail, 10-1/4"W x 9-1/2"L
- Requires BEP43019 Oil Pump Pickup

- BEP43008** 55-79 SBC w/L.H. or D.S. Dipstick (except 62-67 Nova II), Orange
- BEP43012** 80-85 SBC w/R.H. or P.S. Dipstick, Orange
- BEP43013** 86-Up SB Chevy 1-pc. Rear Main Seal Painted Black
- BEP43019** Required Oil Pump Pickup
- BEP47330** SBC Oil Pan Bolts

BIG BLOCK CHEVY STREET/STRIP OIL PAN

- 7 Quart capacity with kick-out sump
- Stamped steel with a welded wide base provides additional ground clearance
- Fit most GM chassis (except 62-67 Chevy II V-8 Monza and Vega)
- Sump size: 8-1/4" from pan rail, 10-1/4"W x 9-1/2"L
- Requires BEP43016 Oil Pump Pickup

- BEP43011** 65-92 BB Chevy Street/Strip Oil Pan Painted Orange
- BEP43016** Recommended Oil Pump Pickup

Installation advisory:
Will not fit stroker motors or aluminum rod engines.



STOCK OEM REPLACEMENT OIL PANS

- Each pan is stamped to OEM specs
- Corner bolt reinforcement tabs
- Factory baffle for stock oil pump location, stock depth

- BEP43000** 55-79 SB Chevy w/L.H. or D.S. Dipstick
- BEP43001** 80-85 SB Chevy w/R.H. or P.S. Dipstick
- BEP43002** 86-UP SB Chevy w/1 P.C. Rear Main Seal
- BEP43020** 65-92 Big Block Chevy
- BEP43040** 65-87 SB Ford Pass. Car, Front Sump
- BEP43041** 83-93 Ford Mustang 5.0 Dual Sump Pan (Not for Trucks or Vans)

PRO SERIES OIL PANS

- Big End Pro Series oil pans are constructed from 100% fixture welded .055" steel
- Features reinforced pan rails with built-in baffling, trap doors, unidirectional windage screen and crank scraper for oil control and added HP. All pans are six quart capacity plus filter
- SBC pans will accept up to 3.875" stroke with steel rods while the BBC pans will accept up to 4.250" stroke with steel rods
- They include a magnetic drain plug; Oil pump pickups are sold separately and can be selected based on the pump type.
- All pans fit most chassis except for 1962-67 Nova.
- 8" deep sump.



- BEP44000** SBC 55-79 2pc Drag Pan
- BEP44005** SBC 55-79 2pc Rear Seal Drag Pan Camaro/ Chevelle
- BEP44010** SBC 80-85 2pc Seal Drag Pan RH Dipstick
- BEP44015** SBC 87-Up 1pc Rear Seal Drag Pan RH Dipstick
- BEP44100** BBC 65-90 2pc Rear Seal Drag Pan Camaro/ Chevelle
- BEP44105** BBC 65-90 2pc Rear Seal Drag Pan
- BEP44110** BBC 1pc Rear Seal Gen V VI Drag Pan
- BEP44200** SBC Standard Volume Pick Up
- BEP44205** SBC High Volume Pick Up
- BEP44210** BBC Standard Volume Pick Up
- BEP44215** BBC High Volume Pick Up

OIL RESTRICTOR

- Big End oil galley restrictors sit flush in the block and do not interfere with any motor plates or flywheels or flexplates like some other hex head restrictors do.
- Features a 0.060" orifice, 1/4" NPT threads, and a 5/16 socket head.
- Made from stainless steel. Fits early and late SB/BB Chevy blocks including bowtie.
- Not for use with hydraulic lifters.



BEP48300 Oil Restrictor SS .060 Chevy, Pair



OIL PUMP DRIVESHAFTS

- Big End Performance oil pump shafts are the perfect choice when looking for a new oil pump drive for your performance engine, made from high grade alloy steel and provide far greater strength than OEM shafts.



BEP44250 SB Chevy Shaft
BEP44255 BB Chevy Shaft



BEP70145 Breather Bottle, Black

OIL BREATHER BOTTLE

- One quart capacity,
- 6AN inlet fitting
- Reusable clamp-on breather
- 2 molded-in mounting inserts



BEP43025 Chrome Steel Magnetic Drain Plug

CHROME STEEL MAGNETIC DRAIN PLUG

- Chrome-plated with 1/2"-20 standard thread
- Nylon washer included



BEP48000 Chevy Oil Filter Adapter

CHEVY OIL FILTER ADAPTER

- Replaces the factory GM oil filter adapter #3952301.
- Includes oil bypass valve, and mounting bolts.
- Fits Chevy V8 engines using a spin-on filter (Wix 51069, AC PF25, Moroso 22459) from 1968 to 1986.

TIMING CHAIN COVERS

- New OE style replacement
- Raw steel, ready to paint



BEP43120 Small Block Chevy
BEP43125 Big Block Chevy
BEP43150 Heavy-Duty Small Block Chevy

FRONT MOTOR PLATES

- CNC machined from 1/4" 6061-T6 aluminum for a precision fit.
- Prevent movement and allow for the engine to be mounted in the original location or setback.
- 1 piece design ideal for most drag and circle track cars.
- Requires trimming to size.



BEP42100 SB Chevy Plate
BEP42105 BB Chevy Plate

POLISHED ALUMINUM TIMING CHAIN COVERS

- Also gives added support to timing chain and camshaft area
- Fits all standard, double roller timing chain sets and some gear drives
- Short water pumps will not fit when using this cover
- New 2 piece timing chain cover allows for quick and easy cam swaps without having to break the oil pan seal.



BEP70082 SB Chevy
BEP70083 BB Chevy
BEP70081 SB Chevy 2-Piece Cover
BEP65150 Chevy Allen-Head Timing Cover Bolts

ALLEN HEAD TIMING CHAIN COVER BOLT KIT

- Grade 5 Allen Head Bolts, Zinc-Plated



BEP65150 Timing Chain Cover Bolts, SB & BB Chevy

TIMING CHAIN COVER BOLT KIT

- 1/4"-20 x 1/2 inch, hex head flange
- Serrated under bolt head
- Zinc plated to resist rust and corrosion



BEP47320 Timing Cover Bolt Kit SBC/BBC 1/4"

OIL PAN BOLT KIT

- 1/4"-20 x 1/2 (14 qty) 5/16"-18 x 3/4 (4 qty), hex head flange design
- Serrated under bolt head
- Zinc plated to resist rust and corrosion



BEP47330 Oil Pan Bolt Kit SBC/Olds V8



HYDRAULIC ROLLER LIFTERS

- Big End retro fit hydraulic roller lifters allow you to take advantage of today's new roller cam technologies when using a pre-hydraulic roller lifter block.
- They feature a vertical link bar and are Made in the USA.

- BEP45000** SB Chevy Hyd. Retro Roller Lifter
- BEP45005** BB Chevy Hyd. Retro Roller Lifter
- BEP45010** SB Ford Hyd. Retro Roller Lifter

LIFTER VALLEY VENTS

- Machined from 6061-t6 aluminum and are designed to help prevent oil drain back on your reciprocating assembly, reduce windage and free up horsepower in the process.
- OEM vent holes must be tapped to 1/4 in. NPT.
- Complete set of 8.



- BEP48315** Lifter Valley Vents

BILLET ADJUSTABLE TIMING POINTERS

- CNC machined aerospace aluminum alloy
- Adjustable pointer + or - 4 degrees
- Black anodized.
- Mounting bolts included



- BEP70400** SB Chevy 6-1/4" Fluidampr
- BEP70401** SB Chevy 6-1/8"
- BEP70402** SB Chevy 6-3/8" ATI Balancer
- BEP70403** SB Chevy 6-3/4"
- BEP70408** SB Chevy 7-1/4" Fluidampr
- BEP70410** SB Chevy 8" Fluidampr
- BEP70412** BB Chevy 6-1/4" Fluidampr
- BEP70414** BB Chevy 7" Balancer
- BEP70415** BB Chevy 7-1/4"
- BEP70418** BB Chevy 8" Fluidampr
- BEP70420** SB Ford, All Timing Position



APPLICATION SHOWN MAY DIFFER OR MAY BE SHOWN WITH MODIFICATIONS

CRANKCASE EVACUATION SYSTEM

- Reduces pressure build-up in the engine crankcase
- Complete kit includes 2 Mopar style breathers, grommets, check valves, tubes and clamps

- BEP70360** Crankcase Evacuation System



ENGINE FASTENER KITS

- Chevy kits include: Timing cover, oil pan, fuel pump, header, water neck, intake manifold, distributor, valve cover and water pump bolt sets (on SBC, short pump only). includes washers
- SB Ford kits include: Timing cover, oil pan, fuel pump, header, filler neck, intake manifold, and valve cover bolt sets. Washers included

CHEVY CAM BUTTONS

- Prevent the cam from walking back and forth in the block giving you more accurate timing and longer timing chain life
- Install with a standard cam lock plate such as BEP48220



ROLLER CAM BUTTONS

- BEP48100** SB Chevy 265-400 .795" Long
- BEP48105** BB Chevy 396-502 .940" Long

ALUMINUM BUTTONS

- BEP48200** SB Chevy, (Flat Timing Cover)
- BEP48205** SB Chevy, (Indented Timing Cover)
- BEP48210** BB Chevy



POLISHED STAINLESS STEEL

- BEP47400** Engine Bolt Kit, SB Chevy
- BEP47405** Engine Bolt Kit, BB Chevy
- BEP47410** Engine Bolt Kit, SB Ford

STAINLESS STEEL

- BEP47420** S/S Engine Bolt Kit, SB Chevy
- BEP47425** S/S Engine Bolt Kit, BB Chevy

CHEVY CAMSHAFT LOCK PLATE & BOLT KIT

- The steel plate installed, bending the tabs against the hex head grade 8 bolts. This prevents the bolt from loosening.
- Black oxide finish. Will not fit engines with factory roller cams.



- BEP48220** Chevy Lock Plate & Bolt Kit

CHEVY SOLID STEEL MOTOR MOUNTS

- Made of 1/4" thick steel; 3-hole mounting 2-11/16" wide, 1-11/16" tall. Center bolt hole to flat
- Black powder coating. Sold in pairs

- BEP42000** Chevy Motor Mounts



PILOT BUSHINGS

- Both are designed to help keep heat down, while the roller bushing reduces friction providing quicker smoother shifts.
- Designed to fit Chevrolet, Olds and Buick applications with a 1.093" OD and a .591" IC



BEP48050 GM HD Bronze Pilot Bushing
BEP48055 GM HD Roller Pilot Bearing

CRANK KEYS

- Heat treated to minimize wear.
- Available for Chevy engine in either a long or short style sold in pairs.



BEP48020 Chevy Crank Keys, Short
BEP48021 Chevy Crank Keys, Long

DOWEL PINS

- These precision manufactured dowel pins are available for SB Chevy, BB Chevy and SB Ford.
- Sold in sets of 4.



BEP48011 SB Chevy Dowels. 4pk.
BEP48012 BB Chevy Dowels. 4pk.
BEP48015 SB Ford Dowels. 4pk.

GUIDE PLATES

- Designed and manufactured for precise fit and function.
- Heat treated, black oxide.
- Requires the use of hardened pushrods.
- Cylinder head machining and screw-in rocker arm studs may be required for installation.
- Made in USA. Sold 8/pkg.



BEP47050 BB Chevy 3/8 Plate
BEP47056 SB Chevy Flat 5/16 Plate
BEP47059 SB Chevy Raised 5/16 Plate



TIMING TAPE

- Designed for high-performance engines to make sure your engine is on time.
- The degree marking range is from 60BTDC to 0 TDC.



BEP70430 SB Chevy, 6"
BEP70431 SB Chevy, 6.75"
BEP70432 SB Ford, 6.375"
BEP70433 BB Chrysler, 7.250"
BEP70434 SB / BB Chevy, 8"

ENGINE ACCESSORY STUDS

- All studs are made from 150K PSI material and feature a hex head but with captive washer and a bullet nose for easier starting.



OIL PAN STUDS
BEP47520 SB Chevy Kit
BEP47525 BB Chevy Kit
TIMING COVER STUDS
BEP47540 SB / BB Chevy Kit
VALVE COVER STUDS
BEP47530 Valve Cover Studs, 8pc. Kit
HEADER STUDS
BEP47515 Header Stud Kit, 12pc Kit

H/P HEAD BOLT KITS

- Heat treated to 180,000 PSI and feature rolled threads and reduced size 12 pt. heads for increased valve spring pocket clearance.
- Extended thread length distributes torque stretch for increased clamping force.
- Extra thick hi-tensile cand chamfered washers are included.



BEP47551 SB Chevy Kit
BEP47556 BB Chevy Kit

HEAD BOLTS

- Made from grade 9 material and feature a cold headed 6-point heads, rolled threads, and Teflon sealer applied for proper seal.
- Each kit contains bolts for a complete engine.



BEP47550 SB Chevy Kit
BEP47555 BB Chevy Kit

INTAKE MANIFOLD BOLTS

- Manufactured from Grade 8 steel and are zinc plated for increased durability and appearance.



BEP47350 SB Chev, 12 pt.
BEP47355 BB Chevy, 12 pt.

PRESSURE PLATE BOLT KIT

- For all GM Borg-Beck/diaphragm style clutches
- Heat-treated to Grade 8 specifications



BEP47300 Pressure Plate Bolt Kit
GM 3/8" - 16 x 1"

ROCKER ARM STUDS

- Precision made from 190,000 psi tensile strength alloy steel and finished in black oxide coating.
- Features large radii for reduced flex and increased strength.
- Designed for use with roller rocker arms and/or stud girdles.
- Not for use with OE type self-locking rocker arm nuts.
- Available in sets of 16.



BEP47560 3/8" Kit, 190k PSI
BEP47565 7/16" Kit, 190k PSI

BALANCER BOLT KITS

- Feature a 180K PSI hi-tensile hex head bolt with an extra thick parallel ground washer for more uniform torque and a hi-tensile lock washer.



BEP47570 SB Chevy Kit 7/16" - 20
BEP47575 BB Chevy Kit 1/2" - 20

ENGINE STANDS

- Gives the ability to rotate your engine block for reassembly of the lower end and top end by simply rotating your engine on the stand.
- The heavy gauge square tube steel frame disassembles easily for storage or transport. Ball-bearing casters allow for easy turning or maneuvering.
- Available in 3 different weight carrying capacities.



BEP40001 1,000 LBS
BEP40002 1,250 LBS

STORAGE BAGS

- Plastic shipping and storage bags keep your engine block, crankshaft or cylinder heads clean and sealed when shipping or storing your newly machined parts. 5/pkg.



BEP43090 Engine Block Bags
BEP43095 Crankshaft/Cylinder Head Bags

ENGINE LIFT PLATE

- Fits all 2BBL, 4BBL, and Dominators
- Heavy gauge steel with 3 hook positions. Zinc-plated



BEP40009 Engine Lift Plate

CRANKSHAFT SOCKET TOOL

- Designed to rotate the engine during short block assembly with the balancer removed
- Accepts 1/2" drive ratchet or breaker bar



BEP41013 BB Chevy
BEP41014 Buick, Olds, Pontiac, Ford
BEP41015 SB Chevy, V6 Chevy, Pontiac 4 cylinder

TOP DEAD CENTER LOCATOR

- Screws into the spark plug hole and positively stops the piston in order to find top dead center.



BEP41052 Top Dead Center Locator, 14mm
BEP41058 Top Dead Center Locator, 18mm

ADJUSTABLE PISTON RING COMPRESSORS

- Eliminates individual bore size ring compressors
- Made of aluminum with a hard coat anodizing and tapered inner diameter compresses the piston rings for a smooth installation



BEP41025 4.000" - 4.090" Diameter Bore
BEP41026 4.125" - 4.205" Diameter Bore
BEP41027 4.205" - 4.310" Diameter Bore

ENGINE CRADLES

- Ideal for engine storage or transportation
- Breaks down for easy storage
- Made of 14 gauge square tubing
- Black powder coated
- 2 models: standard, to be used without wheels; heavy duty, wheels can be added (H.D. models only)
- BEP40022 comes complete with wheels as added value!



BEP40020 Chevy V8 Standard
BEP40021 Chevy V8 HD
BEP40022 Chevy V8 with Wheels
BEP40023 Ford V8 289-351W Standard
BEP40025 Pontiac HD
BEP40026 Chrysler V8 383-440 Standard
BEP40027 Chrysler V8 318 - 360 Standard
BEP40029 Ford V8 429 - 460 Standard
BEP40031 Olds V8 1964-1976 Standard

SAFETY WIRE & PLIERS

- 9" safety wire pliers can be used as a cutter, wire twister, and as pliers.
- Pliers are a spring loaded automatic return style.
- Safety wire is .032 inch stainless steel and comes in a 1 lb. can.
- Used in high vibration areas to keep bolts secure.



BEP41040 Safety wire pliers
BEP41045 Stainless steel safety wire

PRO SERIES OIL PUMP PRIMER

- Pressure bushing for upper valve train lubrication
- Fits SBC and BBC applications



BEP41053 Pro Series Oil Pump Primer

ROD BOLT STRETCH GAUGE

- Check rod bolt yield for correct rod bolt fastener pre-load
- Includes .001" increment dial indicator with a heavy-duty adjustable fixture fits rod bolts up to 2.750" long



BEP41062 Rod Bolt Stretch Gauge

NOISE PROTECTION EARMUFFS

- Lightweight, high impact ABS construction
- Reduces harmful noise
- Ideal for use in shops or at the track



BEP41100 Noise Protection Earmuffs

EZ 2-HANDLE UTILITY JUGS

- Heavy duty polyethylene construction
- 5 Gallon capacity



- BEP40100** White
- BEP40101** Red
- BEP40102** Blue
- BEP40110** Replacement Cap
- BEP40115** Replacement Cap with filler hose kit

11" D-SHAPED FUNNEL

- 18" long w/ built-in anti-splash ring
- Spout can be cut to desired length and diameter
- Use filter screen to prevent debris from entering your system



- BEP40120** 11" Red D-shaped funnel
- BEP40121** Filter screen

EXHAUST HEADER WRAP

- Reduce your under-hood temps by 50%
- Contains header heat for added horsepower
- Protects up to 1,500° F direct heat contact (up to 2,000° F in short bursts)

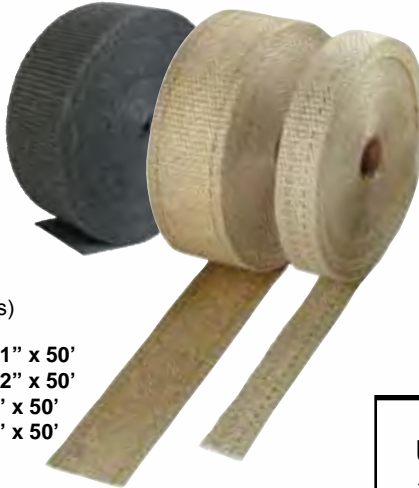

- BEP80100** Natural, 1" x 50'
- BEP80105** Natural, 2" x 50'
- BEP80106** Black, 1" x 50'
- BEP80107** Black, 2" x 50'

VOLCANO HEADER WRAP

NEW!

- Woven volcanic rock tape
- Withstands heat up to 1,500° F.
- 25% stronger and more protective than fiberglass wraps



- BEP80103** Natural, 1" x 50'
- BEP80104** Natural, 2" x 50'

STAINLESS STEEL EXHAUST WRAP TIES

- Made from T-304 stainless steel
- Fireproof, withstand temps up to 2500°F
- Rust and corrosion resistant

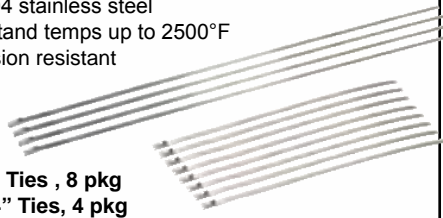

- BEP80108** 8" Ties, 8 pkg
- BEP80109** 14" Ties, 4 pkg

THERMAL TAPE

- Self-adhesive aluminized fiberglass thermal tape
- 1 3/8" wide 15 foot roll
- Protects up to 2000°F radiant heat

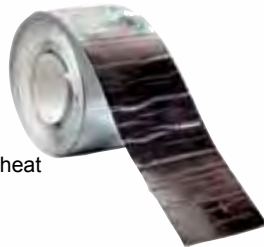

- BEP80115** Thermal Tape

UNIVERSAL HEAT PROTECTION WRAP



- Aluminized fiberglass heat barrier
- Protect starters, carbs, fuel pumps from extreme heat
- Protects up to 2000° F direct heat
- Easily fastens and trims
- 7" wide, 24 inches



- BEP80110** Universal Heat Protection Wrap

BIG END MEANS BIG VALUE!

COLORED SPARK PLUG BOOT PROTECTORS

- Protects up to 1,200° F.
- Easy, slip-on installation can even be used on right-angle boots!
- Halogen free
- Resists gasoline and engine chemicals.

NEW!



- BEP80122** 7.5" Plug Boot, Black (8 pk.)
- BEP80124** 7.5" Plug Boot, Blue (8 pk.)
- BEP80126** 7.5" Plug Boot, Red (8 pk.)

SPARK PLUG BOOT PROTECTORS

- Protect spark plug boots from extreme header heat
- Protects up to 1,200°F
- Heat resistant construction
- Simply slides over spark plug boot



- BEP80120** Spark Plug Boot Protectors, Silver, 7.5" (8 pk.)

PERFORMANCE HEAD GASKETS

- Wire ring head gaskets in various bore sizes, thicknesses, and materials to meet any need.
- Designed to be relied on by the professional racer as well as the Sunday cruiser when it comes to sealing combustion pressure, coolant, and oil under all conditions.
- Sold as packs of 10

SB Chevy
BEP49100 4.166" Bore, .041" (1003)
BEP49105 4.190" Bore, .041" (1004)
BEP49110 4.166" Bore, .039" (1010)
BEP49115 4.200" Bore, .041" (1034)
 Chevy427/454/502 (not GenV/VI)
BEP49130 4.540" Bore, .039" (1017-1)
 Ford 260/289/302/351W
BEP49150 4.100" Bore, .039" (1011-2)

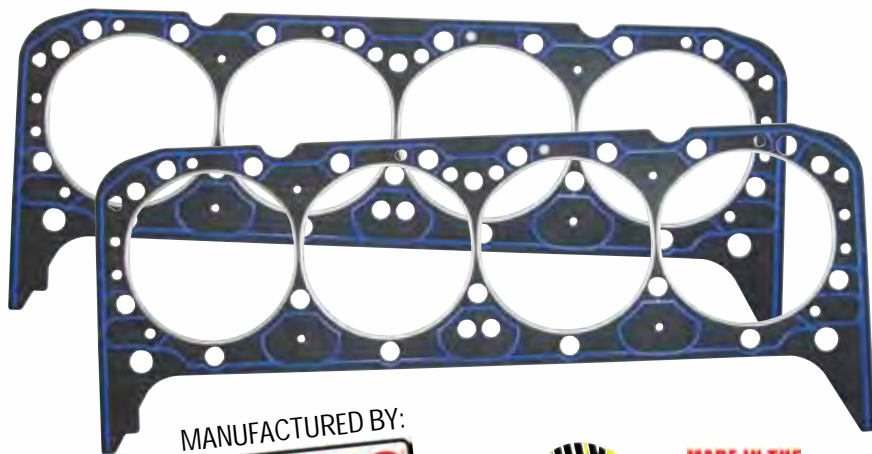

MANUFACTURED BY:



FUEL PUMP GASKETS

- Fits most SB Chevy applications
- Made by Fel-Pro!
- Sold in packs of 10

BEP49605 Fuel Pump Gasket, 10pk.
BEP49610 Fuel Pump Mounting Plate Gasket, 10pk.

MANUFACTURED BY:



RACE TESTED & PROVEN!

Tavoletti / Gearhart 1941 Willys



PERFORMANCE INTAKE GASKETS

- Constructed of selected materials which offer excellent sealing performance while allowing the user to easily trim and match modified port shapes.
- Utilize a synthetic rubber bead where applicable for superior sealing around intake and coolant ports.
- Most Intake Manifold Gasket Sets include blue cork/rubber end strips with adhesive backing.
- Sold in packs of 10

SB Chevy
BEP49200 Port: 1.28" x 2.09", .060" (1205)
BEP49205 Port: 1.31" x 2.21", .060" (1206)
 BB Chevy
BEP49230 Port: 1.82" x 2.54", .060" (1275)

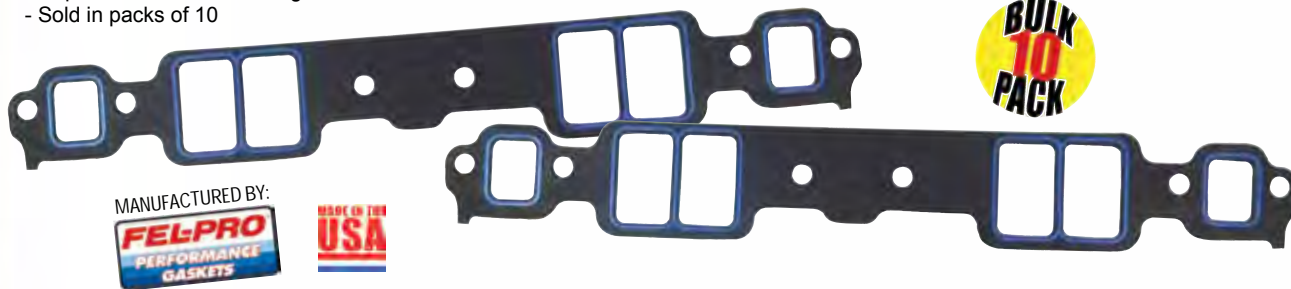

PERFORMANCE EXHAUST GASKETS

- Consist of high-density fiber attached to both sides of a perforated steel core.
- These gaskets can even seal slightly warped surfaces and resist blowout/ burnout from high-temp exhaust gas.
- Nonstick coating allows motion without damage, which simplifies gasket removal for servicing.
- Sold in packs of 10



MANUFACTURED BY:



SB Chevy
BEP49300 Square Vortec, Port size 1.50" x 1.50" (1404)
BEP49305 Square, Port size 1.55" x 1.55" (1405)

VALVE COVER GASKETS

- Silicone rubber with steel core gives added support and prevents gasket slippage and movement
- Sold in pairs

- BEP49418 Blue, SB Chevy 55-86
- BEP49438 Blue, BB Chevy 65-85
- BEP49458 Black, SB Ford 260-289-302-351W
- BEP49410 Black Centerbolt Gaskets 86-97 SB Chevy (Without Steel Core)

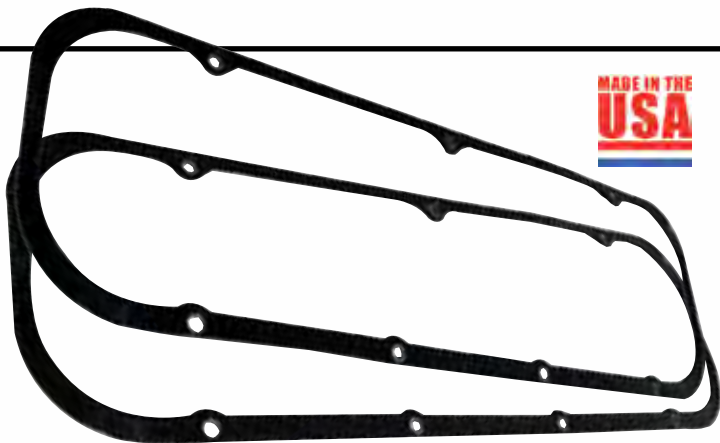

MOLDED SILICONE VALVE COVER GASKETS

- Features solid-steel core and high-tech molded silicone-rubber sealing material
- Great for engines running vac pumps
- Gaskets can be removed and reinstalled easily
- Stainless steel compression limiters prevent over-tightening

- BEP49405 SBC 1955-86 Perimeter Bolt Gasket .340" Thick with 0.250" Limiters
- BEP49435 BBC Molded Silicone Valve Cover Gasket with Steel Core .137" Thick
- BEP49455 SBF Windsor Molded Valve Cover Gasket with Steel Core .200" Thick

PERFORMANCE VALVE COVER GASKETS

- Cork-Lam is used in applications where high vacuum or blowout conditions can be a problem.
- Cork-Lam uses a metal core with cork-rubber material chemically bonded to it on both sides.
- Allows for a thicker than normal gasket with exceptionally good torque retention and also allows for more clearance between the valve cover and valvetrain.
- Sold in packs of 10



- BEP49400 SB Chevy, 5/16" (1604)
- BEP49430 BB Chevy, 5/16" (1630)



TIMING COVER GASKETS

- Designed to deliver a perfect seal on every engine.
- Sold in packs of 10

- BEP49505 SB Chevy
- BEP49535 BB Chevy

WATER PUMP GASKETS

- Designed to deliver a perfect seal on every engine.
- Sold in packs of 10

- BEP49500 SB Chevy Water Pump Gaskets
- BEP49530 BB Chevy Water Pump Gaskets



DISTRIBUTOR MOUNTING GASKET

- Designed to deliver a perfect seal on every engine.
- Sold in packs of 10

- BEP49600 Distributor Gaskets



WATER OUTLET GASKET

- Designed to deliver a perfect seal on every engine.
- Sold in packs of 10

- BEP49615 Water Outlet Gaskets





PRO-FLOW RACING RADIATORS

- 100% aluminum welded construction, for the budget racer
- Cross flow design with a dual 1" tube and 2-1/4" thick core
- Stamped & aluminum furnace welded aluminum side tanks w/ 1-1/2" upper & 1-3/4" lower beaded radiator hose push-on tube
- 3/4" solid upper and lower channel mounting. No gaskets, seals, or epoxy to leak! Must use BEP60552 for over-flow hookup

Ford/Mopar

1-1/2" Upper P.S. outlet, 1-3/4" Lower D.S. inlet

Part #	Overall Size	Core Size
BEP60570	22" x 19"	18" x 18-3/4"
BEP60571	26" x 19"	22-3/8" x 18-3/4"
BEP60572	28" x 19"	24-3/8" x 18-3/4"
BEP60573	31" x 19"	27-1/2" x 18-3/4"
BEP60528	28" x 16"	22-3/8" x 15-3/4"

GM 1-1/2" Upper D.S. outlet, 1-3/4" Lower P.S. inlet

BEP60574	22" x 19"	18" x 18-3/4"
BEP60575	26" x 19"	22-3/8" x 18-3/4"
BEP60576	28" x 19"	24-3/8" x 18-3/4"
BEP60577	31" x 19"	27-1/2" x 18-3/4"
BEP60526	28" x 16"	22-3/8" x 15-3/4"

RACING RADIATOR W/ OIL COOLER

- Features internal aluminum oil cooler
- 1/2" Female NPT fitting, accepts any 1/2" NPT adapter
- 100% Aluminum furnace-brazed welded construction
- 3/4" solid upper and lower channel for easy mounting
- No gaskets, seals or epoxy to leak
- Must use BEP60552 fitting for overflow hookup

GM 1-1/2" Upper D.S., 1-3/4" Lower P.S.

Part#	Overall Size	Core Size
BEP60522	28" x 19" x 3"	24-3/8" x 18-3/4" x 2-1/4"
BEP60524	31" x 19" x 3"	27-1/2" x 18-3/4" x 2-1/4"



POLISHED ALUMINUM RADIATOR CAP

- Polished aluminum hexagon shaped cap
- Billet aluminum cover over a premium 16-pound radiator cap.



BEP60585 Polished Hexagon Radiator Cap

ALUMINUM RADIATOR FAN SHROUDS

- Fits our 19" Radiators exactly, and a close, trim fit on others
- 2.63" High with a 3" trimable collar
- Choose off-center, side to side & above radiator fan positioning
- Shroud is fully-formed from .060 aircraft aluminum
- Adjustable collar, adjusts from 15-20" fan diameters
- Includes all necessary hardware and instructions

BEP60564	22" - Fits all 22"x19" radiators
BEP60565	26" - Fits all 26"x19" radiators
BEP60566	28" - Fits all 28"x19" radiators
BEP60567	31" - Fits all 31"x19" radiators

OVERFLOW OUTLET FITTING

- Made Of aluminum and screws Into the radiator cap neck
- 5/16" Hose, 1/8" Male NPT

BEP60552 Overflow Outlet Fitting



**BIG END
MEANS BIG VALUE!**

ELECTRIC FANS

- Replaces belt-driven fan or for use as an auxiliary cooling fan
- Mounts in front or behind radiator; Reversible: pusher or puller
- Fan only: No controls. Use BEP52023 relay, or 52024 adjustable temp control
- 8-10 AMP Draw



- BEP60018** 10" Dia., RPM 2100 Air Flow 1000 CFM, Mounting Size 11-3/4" x 10-1/2" x 2-1/2"; AMP Draw: 6.5
- BEP60020** 12" Dia., RPM 2340 Air Flow 1200 CFM, Mounting Size 13-3/4" x 12-1/2" x 3-1/4"; AMP Draw: 9.0
- BEP60022** 14" Dia., RPM 2220 Air Flow 1650 CFM, Mounting Size 15-1/4" x 14-1/2" x 3-1/4"; AMP Draw: 9.5
- BEP60025** 16" Dia., RPM 1860 Air Flow 2100 CFM, Mounting Size 17" x 16" x 3-1/4"; AMP Draw: 11.0

S-BLADE FANS

- S-Blades are engineered for a quiet, efficient airflow
- Reinforced nylon shroud withstands high temps
- Fan only: No controls. Use BEP52023 relay, or 52024 adjustable temp control
- Can save up to 17hp & 20 lb. ft. of torque when used as a primary cooling fan



- BEP60080** 12" Dia., RPM 2245, Air Flow 920 CFM, Mounting Size 12-5/8" x 11-3/4" x 2-5/8"; AMP Draw: 8.0
- BEP60085** 16" Dia., RPM 2190, Air Flow 2010 CFM, Mounting Size 16-5/8" x 15-3/4" x 4"; AMP Draw: 13.0

FLEX FANS

- Designed for use in limited clearance applications
- Low pitch reduces drag on engine for hi performance and improved gas mileage. 8,000 RPM rating
- Universal bolt pattern, 5/8" pilot hole
- Stainless blades with gray steel center

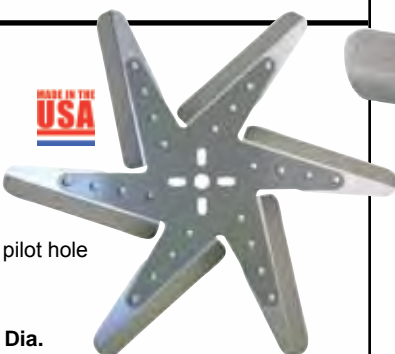

- BEP60000** Flex fan 17" Dia.
- BEP60005** Flex fan 18" Dia.

SEMI-FLEX FANS

- Designed for use on hi-performance vehicles, or towing
- Large blade allows more airflow through radiator
- 8,000 RPM rating
- Flexible stainless steel blades with gray center hub
- Fan shroud is recommended for max cooling
- Std rotation, 5/8" pilot hole



- BEP60010** Semi-Flex Fan 17" Dia.
- BEP60015** Semi-Flex Fan 18" Dia.

SERPENTINE FANS

- Reverse Rotation, serpentine belt applications
- Designed for use on hi-performance vehicles, or towing
- 8,000 RPM rating
- Flexible stainless steel blades with gray center hub
- Fan shroud is recommended for maximum cooling
- Universal bolt pattern, 5/8" pilot hole

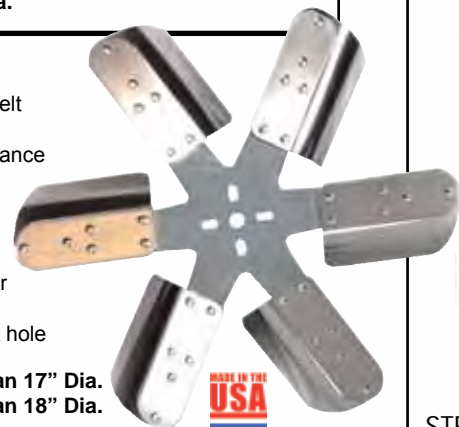

- BEP60011** Rev Rotation Fan 17" Dia.
- BEP60016** Rev Rotation Fan 18" Dia.

ALUMINUM RADIATOR FLANGE MOUNTING KIT

- Features strong lightweight aluminum brackets with slotted mounting holes.
- Sold in pairs



- BEP60551** Radiator Flange Mounting Kit

RUBBER MOUNTING PADS

- Isolate from vibration damage
- GM or universal style
- Cut-to-fit application, sold in pairs



- BEP60555** Mounting Pads, GM Style
- BEP60556** Mounting Pads, Universal

MOLDED NYLON FANS

- Lightweight nylon construction relieves stress from the water pump and bearings provides maximum cooling
- Ideal for race and performance when cost or weight is a concern
- Universal bolt pattern, 5/8" pilot hole
- 8,000 RPM rating



- BEP60040** 14" Dia.
- BEP60041** 15" Dia.
- BEP60042** 16" Dia.
- BEP60043** 17" Dia.
- BEP60044** 18" Dia.

STEEL RADIATOR MOUNTING KIT

- BEP60550** Steel Radiator Mounting Kit



BILLET RADIATOR FILLER NECK

- Replaces damaged filler neck on aluminum radiators
- Heavy duty billet aluminum



- BEP60557** Billet Filler Neck

ALUMINUM RADIATOR INLET & OUTLET KIT

- Includes a 1 3/4" and 1 1/2" beaded hose fittings

- BEP60560** Radiator Inlet and Outlet Kit



TRANSMISSION OIL COOLERS

- Extends transmission life by cooling trans fluid
- Tests show a 20° drop in transmission fluid temperature
- Complete with hardware, hose and fittings for easy installation
- 3/8" hose barb



Trans Cooler Barbed Hose Fittings

- BEP60050** Standard Duty, 12,000 GVW, 5" x 12" x 3/4"
- BEP60055** Added Cooling, 16,000 GVW, 7-1/2" x 12" x 3/4"
- BEP60057** Standard Towing, 18,000 GVW, 7-1/2" x 15" x 3/4"
- BEP60060** Heavy Towing, 20,000 GVW, 7-1/2" x 20" x 3/4"
- BEP60062** Extra Heavy Duty, 26,000 GVW, 10" x 20" x 3/4"

Race Cooler 6AN Fittings

- BEP60075** 16,000 GVW, 7-1/2" x 12" x 3/4"
- BEP60077** 18,000 GVW, 7-1/2" x 15" x 3/4"

OIL COOLER REMOUNT KIT

- Includes 4 nylon bolts, washers, nuts, and rubber spacers



BEP60070 Oil Cooler Remount Kit



ALUMINUM SWIVEL WATER OUTLETS

- 360-Degree Swivel Rotation, extra thick base
- Available in straight, 40 and 90 degree hose angle
- Polished aluminum fits Chevrolet and other applications
- O-ring seal and hardware included

- BEP60120** 40-Degree Aluminum Water Outlet
- BEP60121** Straight Aluminum Water Outlet
- BEP60122** 90-Degree Aluminum Water Outlet
- BEP60126** Replacement O-Ring for Swivel Aluminum Water Necks

ALUMINUM WATER PUMP

- Made of an aluminum alloy, weight savings of 30 to 50% over cast iron
- Heavy duty bearing and seals
- Some aftermarket pulley may require shims (not included)
- 8-Hole Universal Hub, 5/8" Hub Pilot
- Gaskets included



- BEP60300** 55-95 SB Chevy Short Pump Std Rotation
- BEP60305** 55-95 SB Chevy Long Pump Std Rotation



REMOTE ELECTRIC WATER PUMP

- Aluminum housing, billet base, 20 GPM flow rate, billet impeller.
- Anodized for corrosion protection.
- Includes hardware and accepts -12AN o-ring inlet and outlet fittings (sold separately).



BEP60350 Black Pump, Inline Remote Mount

ALUMINUM HEXAGON OVERFLOW TANK

- Complete with chrome barbed inlet fitting and drain valve and mounting brackets.
- 8" tall by 3" in dia.
- Holds 20 oz. of coolant.

BEP60425 Aluminum Overflow Tank



STAINLESS STEEL RADIATOR OVERFLOW BOTTLE

- 8" x 3" bottle stores 20 ounces of excess coolant
- 1/4" inlet & outlet barbed fitting accepts all rubber & plastic tube
- Chrome fittings and drain valve
- Includes stainless steel hardware

BEP60420 Stainless Steel Radiator Overflow Bottle



RADIATOR OVERFLOW BOTTLES

- Made of high strength polyethylene
- One quart capacity, 4" dia. x 8 3/4" tall
- Custom lever petcock for draining
- All mounting hardware included



- BEP60401** Black
- BEP60402** Red
- BEP60403** White
- BEP60404** Blue



**COMPETITION
CHEVY HEI DISTRIBUTOR**

- For Chevrolet V8 engines 262-400 and 396-502 (exc. tall block)
- 100% ALL NEW from cap to gear in a cast aluminum housing
- Includes 50,000 KV HEI coil provides higher output for higher RPM with quicker response
- All-new high performance mechanical advance
- Hardened steel distributor gear, .491" shaft
- RPM range up to 7000 RPM without misfire

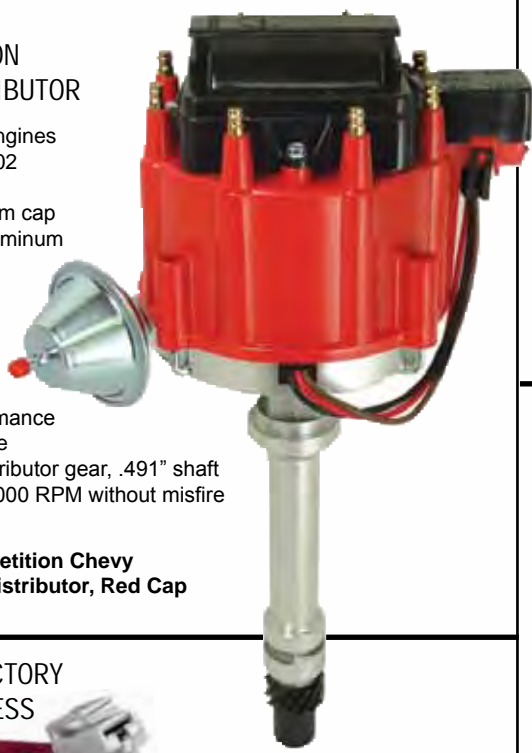

BEP55001 Competition Chevy HEI Distributor, Red Cap

**REPLACEMENT FACTORY
HEI PIGTAIL HARNESS**



BEP54105 GM HEI Pigtail Harness
BEP54106 HEI Tachometer Hookup

BRONZE DISTRIBUTOR GEAR

BEP42050 Chevy .500 Distributor Shaft
BEP42051 Chevy .491 Stock HEI



READY-TO-RUN DISTRIBUTOR

- Provides reliable spark throughout the rpm range, so they'll deliver the performance you need.
- This affordable distributor has many features that outperform the competition, like a lightweight aluminum housing that's precision CNC-machined for strength and stability, polished steel shafts with sealed ball bearings for stable operation through 10,000 rpm, and a maintenance-free, high-output magnetic trigger for accurate and reliable performance.
- Adjustable vacuum advance for easy timing adjustments.



BEP55008 Chevy V-8 (all exc. tall deck) Ready-to-Run Distributor

BEP55087 Replacement Cap & Rotor Kit



HEI VACUUM ADVANCE LOCKOUT

- Allows you to lockout the vacuum advance on GM HEI distributors, by removing the vacuum advance and replacing it with this

BEP55092 GM Vacuum Advance Lockout

ADJUSTABLE VACUUM ADVANCE

- Adjustable Vacuum Advance for HEI replaces your OE non-adjustable unit
- Allows you to change the amount of ignition vacuum advance for maximum performance while preventing detonation
- Increases throttle response and horsepower while improving performance and fuel economy



BEP55091 GM HEI Adjustable Vacuum Advance

RACING DISTRIBUTOR CLAMP

- Large rugged clamp reduces the chance of timing changes because of a loose distributor
- Fits all SB Chevy BB Chevy and 90° V6 engines



BEP55015 Racing Distributor Clamp

BILLET DISTRIBUTOR HOLD DOWNS



- Superior clamping
- CNC machined from 6061-T6 Aluminum
- Anodized for long lasting beauty
- Fits all SB/BB/90° V6 Chevy engines
- Includes stainless steel stud



BEP55100 Distributor Hold Down, Clear
BEP55101 Distributor Hold Down, Blue
BEP55102 Distributor Hold Down, Red
BEP55103 Distributor Hold Down, Black

HEI H.O. TUNE-UP KIT

- Kit includes everything you need to rebuild your HEI distributor including a Hi-Output 50K volt coil, new cap and rotor with wire retainer, coil dust cover, low saturation ignition coil, adjustable vacuum advance unit, HEI bushing, wiring harness and capacitor, and a high performance advance spring & weight kit.



BEP55025 HEI H.O. Tune-Up Kit

PRO-SERIES IGNITION COIL

- This coil is designed to work with our Pro Series ready-to-run distributors.
- It features heavy gauge windings that are engineered to ensure maximum power at higher RPM levels, and its heavy duty housing with epoxy encapsulation resists shock and vibration and provides excellent conductivity.



BEP55043 Pro Series CD Coil

PUSH BUTTON SWITCH WITH CORD

- For use with trans brake, line lock, or nitrous
- Coiled cord for easy mounting

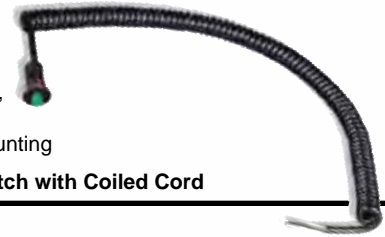

BEP52015 Micro Switch with Coiled Cord

UNIVERSAL IGNITION COIL

- 12-volt heavy duty, 40,000 volt coil
- Oil filled canister keeps the coil cool and reliable
- Includes chrome bracket



BEP55044 Chrome Coil with Bracket

SPARK PLUG WIRE DIVIDER KIT

- Pro Style wire separator kit fits wires from 8mm to 9mm.
- Each kit includes 2 plastic 2-hole separators, 2 plastic 3-hole separators, and 2 plastic 4-hole separators.



BEP55110 Spark Plug Wire Separator Kit

GM HEI ADVANCE CURVE KIT

- Recurve a GM HEI for full spark advance and high RPM
- Contains weights, centerplate, 3-sets of springs, 4 nylon bushings



BEP55050 GM HEI Advance Curve Kit 1974-79

TOGGLE SWITCHES

- Heavy duty 25 amp rating
- Screw terminals
- On/off single throw, used for fuel pumps, electric fans, etc.



BEP52000 Toggle Switch Short Handle 11/16" (ea.)
BEP52005 Toggle Switch Long Handle 1-1/2" (ea.)

AIRCRAFT STYLE SWITCH COVER

- Stops accidental switch on or off
- Fits most standard toggle switches
- Switch sold separately



BEP52050 Aircraft Style Cover

BRAIDED FLEXWRAP

- Lightweight, soft to quiet vibrations, abrasion resistant, and flame retardant
- Flexwrap retains its shape and rigidity throughout temperatures from -94°F to 257°F



	Size	Length	Size	Length
BEP56000	1/8"	25'	BEP56004	3/4" 8'
BEP56001	1/4"	20'	BEP56005	1" 8'
BEP56002	3/8"	12'	BEP56006	1-1/2" 4'
BEP56003	1/2"	10'		

HIGH QUALITY PRODUCTS
PRICED RIGHT!

BIG END
MEANS BIG VALUE!

COMPLETE UNIVERSAL VEHICLE WIRING HARNESS



- This complete vehicle wiring harness features a 15-fuse 38 terminal block with 24 circuits that include keyless entry units, gauges, electric fan, choke, cruise control, power windows, power seats, heater, wipers, radio, headlights, flashers, dome light, and two accessory outputs. Color coded and labeled to make installation and future wiring easier
- Wiring harness comes complete with a fuse block with flashers, relay, headlight switch, dimmer switch, ignition switch with lock and keys, color coded wiring, and installation instructions

BEP52100 Complete Universal Vehicle Wiring Harness

WEATHER PACK CONNECTORS

- The unique design of the weather pac connector provides reliable connections that are not affected by water, oil, gasoline, dirt, vibration or temperature
- Connector locks together and provides each terminal with its own barrel, which leaves no chance of shorting
- Each terminal has silicone seals with multiple sealing ribs to prevent contaminants from entering through the wire or nylon housing
- Connectors, terminals, seals & installation tools sold separately



BEP54000 2 Pin Weather Pac Connector, 5 Pk.
BEP54001 3 Pin Weather Pac Connector, 5 Pk.
BEP54002 4 Pin Weather Pac Connector, 5 Pk.
BEP54003 6 Pin Weather Pac Connector, 5 Pk.
BEP54020 18-20 Gauge Wire Terminal & Seals, 10 Pk.
BEP54021 14-16 Gauge Wire Terminal & Seals, 10 Pk.
BEP54022 12 Gauge Wire Terminal & Seals, 10 Pk.
BEP54030 Extractor & Installation Tool
BEP54031 Crimping Tool

ELECTRIC FAN PIGTAIL

- Simplifies the installation of most Big End electric fans



BEP54100 Electric Fan Pigtail, 12" Long, 2-Wire Lead

UNIVERSAL 40-AMP RELAYS

- Universal applications, electric fans, fuel pumps, etc
- 5 pin relay, 40 amp relay



BEP52010 40 Amp Relay w/ Harness
BEP52008 Universal 40 AMP Relay, Single Pole

WEATHER PACK STARTER KIT

- Weather pack Starter kits include 101 pieces and have enough components to make 13 connections.
- Starter kit includes enough pieces to do two 4-pin, three 2-pin, four 1-pin, and four 3-pin connectors.
- Includes 80 terminals, 50 seals, and 26 housings



BEP54040 Weatherpack Starter Kit

ELECTRIC RELAY KITS

- Heavy duty protection, provides continuous supply of voltage to the electric water pump or electric fan
- Kit includes a 40 amp relay, 48" long wire harness, assorted terminal connectors (not shown), and instructions



BEP52022 Electric Water Pump Relay Kit
BEP52023 Electric Fan Relay Kit
BEP52020 Fuel Pump Relay Kit

ADJUSTABLE THERMOSTAT CONTROL SWITCH

- This adjustable electric fan thermostat control operates electric fan(s) at any temperature setting between 180° and 240° F
- A capillary tube sensor probe slides in between the radiator hose and radiator tubing into the coolant flow path
- Kit includes an adjustable sensor control box, mounting bracket, 10 feet of wiring, connectors, & installation instructions



BEP52025 Adjustable Thermostat Control Switch

ELECTRIC FAN RELAY KIT WITH THERMOSTAT

- Provides protection of a relay for continuous voltage supply
- Includes a 40 amp relay, 48" long wire harness, temp sensor with 3/8" NPT threads, terminals, connectors, & instructions
- Turns on at 180°, off at 175°



BEP52024 Electric Fan Relay Kit with Thermostat
BEP52007 Replacement 180° Thermostat Sensor

STARTER SOLENOID RELOCATION KIT

- Mounts a new starter solenoid in a cooler spot away from exhaust heat.
- Includes a Ford style remote starter solenoid, terminal ends, all necessary wiring and instructions.



BEP52021 Starter Solenoid Relocation Kit



CHEVY DENSO STARTER

- Fits all small blocks, big blocks and 90° V6 engines
- Dual pattern mounting for 153 and 168 tooth flywheels
- Delivers 180 ft. lbs. of torque
- 4.4:1 gear reduction
- Mounting bolts included

BEP50004 Chevy Denso Starter 153/168 Tooth Flywheel

CHRYSLER MINI STARTER

- Weight: 10.5 lbs., Amp Draw: 80 to 90
- Solenoid housings sealed with O-rings for added protection
- Full ball bearing construction for lasting performance
- Billet aluminum adapters with 4 adjustable mounting positions

BEP50023 SB / BB Chrysler Mini Starter

NEW!

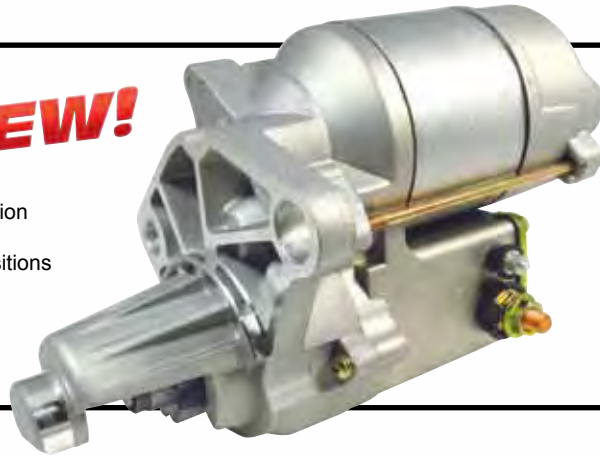

NEW CHEVY PRO MINI STARTER

- 100% new, manufactured by Hitachi
- Higher torque power for up to 18:1 compression
- 1" longer armature, 2.68 horsepower with 2.0 KW motor and 3.75:1 gear reduction
- Fits all V-8 and V-6 Chevy engines w/153 & 168 tooth flywheel
- Works with kick-out oil pan
- 3 clock mounting positions, comes with mounting bolts & shims

BEP50002 New Chevy Pro Mini Starter, Hitachi Style

CHEVY PERMANENT MAGNET STARTER

- Utilizes reliable permanent magnetic coaxial tech
- 1.4KW motor, 6:1 Ratio
- 30% lighter than a typical mini-starter its size
- Fits all small blocks, big blocks and 90° V6 engines
- 360° mounting positions for max installation clearance
- Strong enough to turn 13:1 compression engines
- Weighs 7.5lbs

BEP50064 Permanent magnet Chevy starter



REPLACEMENT STARTER BOLT SET

- Includes bolts and shims

BEP50020 Starter Bolt Kit



PUSH BUTTON STARTER SWITCH

- 35 amp, 12 volts

BEP50025 Push Button Starter Switch





REBUILT CHEVY MINI STARTER

- Rebuilt Hitachi style starter fits all V-8 and V-6 Chevy engines w/153-168 tooth flywheels
- Works with kick-out oil pan, 3.7:1 gear reduction, delivers 165ft. lbs. of torque to spin engines up to 11:1 compression
- 3-clock mounting positions, mounting bolts included
- Weight 11 lbs.

BEP50000 Rebuilt Chevy Mini Starter, Hitachi Style

CHROME MINI STARTER

- Chrome mini starter has a 1.9HP Hitachi-style motor, 90 amp draw, 3.7:1 gear ratio, full ball bearings, and the power to crank over engines with up to 12.1 compression
- Fits straight across mounting; Works on both 153 & 168 tooth flywheels

BEP50003 Chrome Chevy Mini Starter



PONTIAC & OLDS DENSO STARTER

- Fits all 326-455 V8 Pontiac and all 350-455 Olds engines
- Delivers 180 ft. lbs. of torque
- 4.4:1 gear ratio

BEP50009 Pontiac & Oldsmobile Denso Starter

BIG BLOCK FORD DENSO STARTER

- Fits all 351C-351M-400-429-460 engines
- Delivers 180 ft. lbs. of torque
- 4.4:1 gear reduction ratio

BEP50018 Ford Big Block Denso Starter 351-460

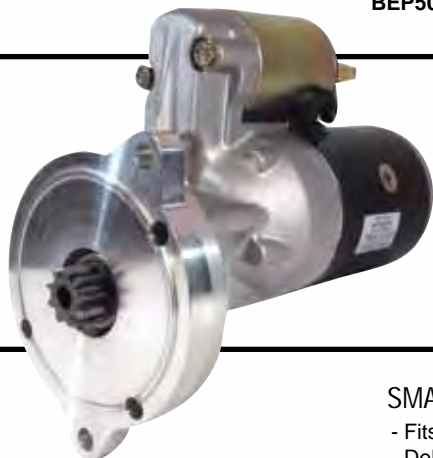

NEW FORD MINI STARTER

- 100% new, manufactured by Hitachi!
- Higher torque power for up to 14:1 compression
- 1.4 KW motor provides 40-50% more torque than O.E.
- Fits all Ford 221-289 - 302 - 351W (and 300 L6 engines w/SA738 starter)
- Works with kick-out oil pan, more clearance for headers
- 3.7:1 gear reduction

BEP50060 Ford Mini Starter, Automatic Transmission

SMALL BLOCK FORD DENSO STARTER

- Fits all Ford 289 - 302 - 351W engines
- Delivers 180 ft. lbs. of torque
- 4.4:1 gear reduction ratio
- Designed to fit all automatics and 5-speed transmissions

BEP50017 Ford Small Block Denso Starter, 289-351W

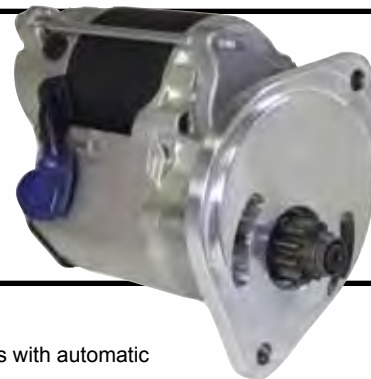

CHRYSLER DENSO STARTER

- Fits all Chrysler small and big block, V8 engines with automatic and manual transmissions
- Delivers 180 ft. lbs. of torque
- 4.4:1 gear reduction ratio
- No clock-positioning

BEP50013 Mopar Denso Starter

MASTER POWER DISCONNECT SWITCH

- Required in all categories of racing to cut the main power supply between the battery and the electrical system
- NHRA and IHRA approved
- A quick-twist/non-slip lever provides a fast power cut-off. Rated at 175 amps continuous; 1,000 amps intermittent
- Fits panels up to 3/16" thick



- BEP50030 Master Power Disconnect Switch, Single Pole (Battery Only)**
BEP50031 Master Power Disconnect Switch for Vehicle with an Alternator Charging System. Double Pole



- ON-OFF FACE PLATE**
BEP50035 On-Off Face Plate

CHROME GM ALTERNATORS

- Chrome plated GM Delco-Remy, new or rebuilt alternators
- 1 or 3 wire hookup
- 100% new components,
- Built-in voltage regulator



- BEP50051 65 amp Alternator**
BEP50050 100 amp Alternator
BEP50055 140 amp Alternator

GM ALTERNATOR PIGTAIL ASSEMBLY

- Clips on the alternator terminal just like stock and will NOT vibrate off
- Will allow you to use 1-wire alternators just like stock
- Works with GM 10SI and 12SI series alternators



- BEP54110 GM Alternator Pigtail Assembly**

XHD MASTER DISCONNECT SWITCH

- This switch is compatible with both 12 volt and 16 volt systems and is rated at 300A continuous and 2000A momentary
- Switch requires a 3/4" mounting hole and has 1/2" terminals. Faceplate available separately



- BEP50032 XHD Master Disconnect Switch**
BEP50036 Faceplate for XHD switch

CIRCUIT BREAKERS

- A circuit breaker, unlike a fuse, can be re-used after an overload

- BEP52060 40 Amp Breaker**
BEP52061 30 Amp Breaker
BEP52063 20 Amp Breaker



REMOTE-MOUNT ALUMINUM BATTERY BOX KIT

- Allows you to move your battery to the trunk for better weight transfer.
- Kit comes complete with battery box, hold downs, and battery cable.



- BEP58100 Aluminum Battery Box Kit**

BOLT-ON BATTERY BOX

- Die formed steel; Lightweight yet strong.
- Variety of mounting holes
- Includes pivoting hold down bolts, lock nuts, & aluminum hold down strap.
- Dimensions are 11" X 7" inside.



- BEP58110 Adjustable Tray**

BATTERY CABLE END DISCONNECT SWITCH

- 100 amps rated, for 12 or 24 volt systems



- BEP50044 Cable End Disconnect Switch**

THRU-PANEL BATTERY CONNECTOR

- Can be used to provide a solid connection through firewall or any panel
- 1-1/4" diameter hole, Sold each



- BEP50045 Thru-Panel Battery Connector**

REMOTE BATTERY JUMPER TERMINALS

- Allows battery to be placed anywhere in the vehicle
- Sold separately



- BEP50040 Red (Positive)**
BEP50041 Black (Negative)

ELECTRICAL QUICK CONNECTS

- Kits include two genderless housings and four contact terminals
- Terminals can be crimped or soldered



- BEP54200 Quick Connect 1/0 AWG, to 175 amps**
BEP54210 Quick Connect 6 AWG, to 50 amps

STUD TYPE

REMOTE BATTERY JUNCTION BLOCKS

- Kits include one Positive (Red) and one Negative (Black) terminal block with either a 3/8", or 10-32 studs that allow for the connection of battery cables through a bulkhead



- BEP50070 3/8" Junction Block Kit 1 Positive 1 Negative**
BEP50071 Replacement 3/8" Junction Block Negative (Black)
BEP50072 Replacement 3/8" Junction Block Positive (Red)
BEP50075 10-32 Junction Block Kit 1 Positive 1 Negative
BEP50076 Replacement 10-32 Junction Block Negative (Black)
BEP50077 Replacement 10-32 Junction Block Positive (Red)

14" CHROME AIR CLEANER TOP

- 14" Muscle car style top
- Chrome plated steel



BEP70015 Air Cleaner Top 14"

AIR CLEANER BASES

- 14" diameter air cleaner base for all 4500 series Dominators



BEP70011 Dominator Base
BEP70012 Offset Base

HI-FLOW AIR CLEANER ASSEMBLIES

- Fits 5-1/8" carb neck
- Washable and reusable 3" element
- Less restrictive than paper elements; Filters small dirt particles
- Increases horsepower!
- Stud with wing nut included
- Measurements shown; air cleaner mounting surface to top



BEP70510 Hi Flow Filter, Semi-recess, 3-1/2"
BEP70511 Hi Flow Filter, Recessed, 2-7/8"
BEP70512 Hi Flow Filter, Flat, 4-1/2"

BIG FLOW AIR CLEANER ASSEMBLIES

- Provides excellent filtration and Big Air Flow
- Washable and reusable 3" element
- Less restrictive than paper elements; Filters small dirt particles
- Fits 5-1/8" carb neck
- 14 inch top has black anodized accent ring, chrome steel base
- Stud with wing nut included
- Measurements shown; air cleaner mounting surface to top



BEP70500 Filter Assembly, Semi-recessed, 3-3/4"
BEP70501 Filter Assembly, Recessed, 3"
BEP70502 Filter Assembly, Flat, 4-1/2"



HIGH FLOW CLEANER ELEMENTS

- 14 inch filter elements are washable and reusable

BEP70520 14 x 3 Inch **BEP70526 14 x 5 Inch**
BEP70521 14 x 2 Inch **BEP70527 14 x 6 Inch**
BEP70522 14 x 4 Inch



BIG FLOW AIR CLEANER TOPS

- Replaces 14" filter tops
- Washable and reusable!
- Increases horsepower!
- Pre-oiled, ready to go!

BEP70515 Chrome Trim Ring
BEP70516 Black Trim Ring



REPLACEMENT FILTER ELEMENT

- 14" x 3" air cleaner element replacement

BEP70010 Air Cleaner Element

AIR CLEANER STUDS

- 1/4"-20 threaded offset stud with nuts
- Standard Kit contains a 1/4"-20 x 6" Stud and wing nut

BEP70019 Offset Air Cleaner Stud Kit (for use w/ offset base)
BEP70017 Air Cleaner Stud & Wing Nut

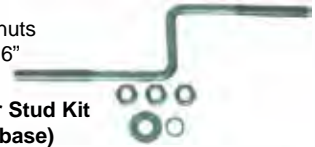

POLISHED ALUMINUM VALVE COVERS

- Highly polished covers with a smooth finished top
- No breather holes
- Tall valve covers that clear aluminum rocker arms
- Mounting bolts included



BEP70030 Small Block Chevy, Tall 3-11/16"
BEP70032 SB Chevy Centerbolt 1986-95, Tall 3-11/16"
BEP70035 Big Block Chevy, Tall 3-11/16"
BEP70038 SB Ford 289-351W 3-11/16" Tall

POLISHED ALUMINUM VALVE COVERS W/ BREATHER HOLES

- Highly polished covers with a smooth finished top
- Tall valve covers clear most aluminum rocker arms
- Mounting bolts included



BEP70034 SB Chevy 58-86 Covers 3-11/16" Tall
BEP70033 SB Chevy 87-97 Centerbolt Covers
BEP70039 SB Ford 62-85 289-302 Covers 3-11/16" Tall
BEP70041 BB Chevy 65-95 Covers 3-11/16" Tall



FABRICATED ALUMINUM VALVE COVERS

- Fabricated lightweight 3003 H-14, .0125" thick aluminum
- Tig-Welded to maintain gasket rail flatness and prevent leaks
- Clears most popular rocker arm combinations
- Fasteners included
- Now with 1/4" Billet rails
- LS1 covers include oil cap, and o-ring gasket

- BEP70300** BB Chevy 3 1/2" Tall
- BEP70320** SB Chevy 3 3/4" Tall
- BEP70325** SB Chevy, Centerbolt
- BEP70330** LS1 Chevy 2-1/2" Tall w/ Coil Mounts
- BEP70340** SB Ford 3 1/2" Tall
- BEP70335** LS1 Chevy w/o Coil Mounts

ALUMINUM OVAL TRACK VALVE COVERS

- Highly polished covers with a smooth-finished top
- Driver side had two 1 3/8" OD tubes with baffles
- Passenger side is plain with no holes or tubes

- BEP70036** SB Chevy 55-86 Covers 3-11/16"
- BEP70037** SB Chevy 87-97 Centerbolt Covers 3-11/16"

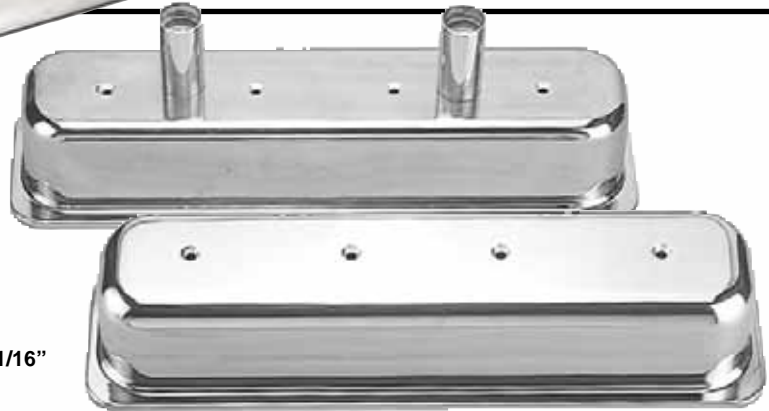

STEEL OVAL TRACK VALVE COVERS

- Stamped steel, tall valve cover
- Raw Steel or Zinc plated
- 1-1/2" breather tubes



- BEP47100** SB Chevy Raw Steel, 3-11/16"
- BEP47101** SB Chevy Zinc Plated, 3-11/16"

OIL FILLER CAP

- Chrome-plated steel
- Push-In 1-1/4" Hole
- No grommet required

- BEP70140** Push-On Cap



PUSH-IN CHROME BREATHERS

- Chrome plated steel
- For Valve covers with 1-1/4" holes

- BEP70135** Breather
- BEP70133** Mopar Style w/Tube



BIG FLOW BREATHERS

- Chrome plated steel top
- High flow open element design
- Available with or without shield



- BEP70136** Push-In 1-1/4" Hole Open
- BEP70137** Clamp-On 1-1/2" Tube Open, Rubber Base
- BEP70138** Push-In 1-1/4" Hole Shielded
- BEP70139** Clamp-On 1-1/2" Tube Shielded, Rubber Base
- BEP70141** Clamp-On 1 3/8" Tube Non-shielded, Rubber Bs.
- BEP70142** Clamp-On 1 3/8" Tube Shielded, Rubber Base

BREATHER GROMMETS

- Fits into 1-1/4" dia. hole for 1" push-in breather
- Made of neoprene.
- Sold in pairs

- BEP70125** 1-1/4" Hole Grommets (Pair)
- BEP70124** 3/4"-1-1/4" OD Steel Valve Cover (PVC Type)
- BEP70123** 3/4"-1-1/4" OD Aluminum cover (PVC Type)



BILLET BREATHER CLAMP

- Made from a billet 6061-T6 construction and outfitted with rubber grommet, and stainless steel hardware.
- Clear anodized. Will fit standard 1-1/4" valve covers as well as 1.22" to 1.25" push in style.

- BEP70143** Billet Breather Clamp



VALVE COVER SPREADER BARS

- Chrome-plated steel
- Gives support to valve cover rail to prevent oil leakage
- Distributes clamping pressure evenly for better sealing

BEP70190 SB Chevy Spreader Bars, Qty 4
BEP70195 BB Chevy Spreader Bars, Qty 7



BILLET BREATHER CLAMP

- Mounts on valve cover
- Uses standard push-in breather
- Meets NHRA & IHRA requirements

BEP70134 Billet Breather Clamp



BILLET VALVE COVER BAFFLE

- Install a breather where a breather hole didn't exist!
- Dual o-ring design works with most standard 1.22" push-in style breathers and requires a 1-3/8" diameter hole.

BEP70144 Billet Baffle Kit



VACUUM RESERVE CANISTER

- All steel construction available in a black or chrome finish
- Comes complete with a one way check valve, mounting bracket, and mounting hardware.

BEP48500 Canister, Black Steel
BEP48505 Canister, Chrome Steel

BILLET FILLER CAP KITS

- Universal cap, can be used for multiple applications including valve cover oil fill, rear end filler, overflow tank cap, dry sump tank cap or whatever you can think of
- Made of CNC machined 6061-T6 aluminum bar stock

BEP70350 Billet Cap with Aluminum Bung
BEP70355 Billet Cap with Steel Bung
BEP70351 Billet Cap Kit w/ Alum. Bolt on Bung



CHROME VALVE COVER MINI-TABS

- Valve cover hold down tabs distribute pressure more evenly for better sealing
- Universal set of 8

BEP70193 Chrome Valve Cover Mini-tabs, 8 pack



T-BAR WING NUTS

- Extra long Style 5-5/8" with a 1/4"-20 x 1-3/8" stud. 4 Per Package

BEP70150 Chrome, T-Bar Wing Nuts



POWER STEERING PUMP PULLEYS

BEP60295 Aluminum Pulley, V-Belt
BEP60296 Chrome Pulley, V-Belt



REPLACEMENT VALVE COVER BOLT KIT

BEP70170 Bolt Kit 70035/41
BEP70171 Bolt Kit 70300
BEP70172 Bolt Kit 70032/33
BEP70173 Bolt Kit 70320

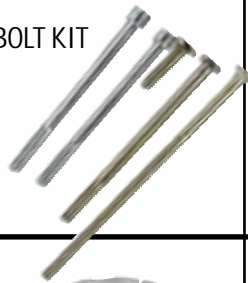

POWER STEERING PUMP

- Dress up your engine with our chrome Saginaw-style power steering pump.
- Fits most GM 66-76 Saginaw 5/8" keyed shaft style applications.
- Shipped without a pulley so you can choose from either the standard V-Belt or a Serpentine style belt with a 5/8" keyed shaft.
- Utilizes a 5/8"-18 fitting (not included).

BEP20555 Power Steering Pump, Chrome, Saginaw



BILLET POWER STEERING PUMP MOUNT KIT

- No more need to search for a power steering bracket at the local junk yard, Big End now offers the right solution to mount non-metric GM Saginaw style power steering pumps
- Available for both Small Block Chevy and Big Block Chevy engines and for both short and long water pumps
- Made from 6061-T6 aluminum includes all stainless steel hardware

SB CHEVY
BEP50150 Bracket SBC Short Pump
BEP50155 Bracket SBC Long Pump
BB CHEVY
BEP50160 Bracket BBC Short Pump
BEP50165 Bracket BBC Long Pump



POWER STEERING PUMP NOT INCLUDED

BILLET ALUMINUM ALTERNATOR BRACKET KIT

ALTERNATOR NOT INCLUDED



- Here is your answer for mounting your alternator when using an aftermarket electric water pump
- Made from 6061-T6 aluminum and clear anodized this mount will work with all aftermarket electric water pumps
- Bracket mounts in the mid mount position on the passenger side of the engine & mounts a standard full-size GM alternator
- Kit includes all stainless steel hardware and instructions.

BEP50140 SBC w/ Electric Water Pump
BEP50145 BBC w/ Electric Water Pump



LOW-MOUNT ALTERNATOR BRACKET

- Fits all SB Chevy engines, left side mounting. Fits Short water pump only
- Moves the alternator to the bottom left side of engine
- Chrome plated

BEP50131
Low Mount Bracket Kit

COPPER COLLECTOR GASKETS



- Embossed copper collector gaskets
- O-ring design for a tight leak proof seal
- Sold in pairs



BEP81001 2-1/2" Dia. Collector, Triangular
BEP81006 3" Dia. Collector, Triangular
BEP81011 3-1/2" Dia. Collector, Triangular

COPPER EXHAUST HEADER GASKETS

- Gaskets are made from .043" dead-soft copper material, annealed for strength
- Embossed O-ring for tight leak-proof seal
- Will not shrink, deteriorate, or blowout, even in severe duty applications
- Pair/package



- Small Block Chevy 283-400
BEP82300 1.50" I.D. Round
BEP82302 1.50" x 1.437" Lg Sq
BEP82304 LT1 Chevy D-Port
BEP82305 LS1 and GEN3 Engines
 Big Block Chevy 396-502
BEP82320 1.75" x 1.75" Stock Square
BEP82322 1.875" I.D. Round
BEP82324 2.275" I.D. Round
 Small Block Ford 289-302
BEP82340 Stock Port
 Ford FE 352-428
BEP82350 Ford FE 352-390 Light Truck
BEP82352 Ford FE 390-428 Stock Head
 Ford Big Block 429-460
BEP82354 BB Ford Oval Ports
 SB Block Chrysler 273-360
BEP82360 All 4-Barrel Head Thru 1990
 Big Block Chrysler 383-440
BEP82364 1.700"x 1.475" - Max Wedge
BEP82366 1.625"x 1.125" Stock Port
 Oldsmobile 350-455
BEP82380 V-8 Stock Head
 Pontiac 326-455
BEP82386 D-Port Heads
 AMC 360-401
BEP82390 Dog Leg Port



ALUMINUM-SEAL COLLECTOR GASKETS

- Made of "Dead Soft" aluminum that conforms to create a leak-proof seal
- Will not burn or blow out
- Chrome plated nuts and bolts included



BEP80080 2-1/2" Dia. Collector Gaskets, 2pk.
BEP80082 3" Dia. Collector Gaskets, 2pk.
BEP80084 3-1/2" Dia. Collector Gaskets, 2pk.

ELECTRIC EXHAUST CUTOUTS

- Bolt directly to a standard triangular 3-bolt exhaust flange for 3" pipe.
- Control the exhaust flow path and go from stealthily quiet to wide-open in a matter of seconds.
- Fit any car or truck, muscle car, street rod or high-tech import.

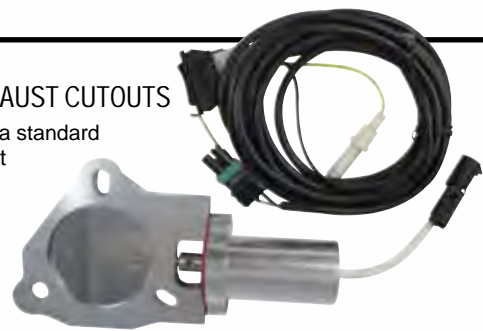

BEP82500 Single 3" Cutout Kit
BEP82505 Dual 3" Cutout Kit

O2 SENSOR BUNG & PLUG

- Standard 18 mm thread
- Stepped style bung for easy installation

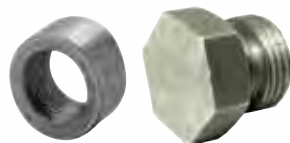

BEP80060 O2 Bung
BEP80065 O2 Plug

HIGH QUALITY PRODUCTS PRICED RIGHT!

BIG END MEANS BIG VALUE!

A

Accelerator Pump Diaphragm	14
Air Cleaner Base	51
Air Cleaner Elements	51
Air Cleaner Studs	51
Air Cleaner Top	51
Alternator Pigtail Assembly	50
Alternators	50

B

Back-Up Washers	25
Battery Box	50
Battery Connector	50
Battery Disconnect Switch	50
Battery Junction Blocks	50
Battery Terminals	50
Billet Line Clamps	32
Bolts, Balancer	37
Bracket, Alternator	54
Bracket, Fuel	16
Bracket, Fuel Pressure Regulator	13
Bracket, Kick Down	15
Bracket, Throttle Cable	13-14
Brackets and Tabs	23-24
Brake Lines	31
Breather Clamp	52, 53
Breather Grommets	52
Breathers	52

C

Camshaft Lock Plate & Bolt Kit	36
Carburetor Adapter Kit	12
Carburetor Cover Cap	15
Carburetor Jets	15
Carburetor Rebuild Kits	15
Carburetor Spacers	12
Carburetor Stud Kit	15
Carburetor, Line Kits	6
Chevy Cam Buttons	36
Circuit Breakers	50
Cleco Pins	25
Cleco Pliers	25
Crank Keys	37
Crankcase Evacuation System	36
Crankshaft Socket Tools	38
Cross Pins	28

D

Dial-In Boards	21
Dial-In Markers	21
Distributor Clamp	45
Distributor Gears	45
Distributor Hold Downs	45
Distributors	45
Dominator Shear Plates	13
Dowel Pins	37
Drill Bits	25
Driveshaft Safety Loop	32
Dual Return Springs	14

E

EGR Block Off Plate	10
Electric Exhaust Cutouts	54
Electrical Quick Connects	50
Engine Accessory Studs	37
Engine Cradles	38
Engine Fastener Kit	36
Engine Lift Plates	38
Engine Racing Formula	33
Engine Stands	38
Engine Thermometer	20
Exhaust Header Wrap	39
Exhaust Wrap Ties	39

F

Fans	43
Filler Cap Nuts	53
Fittings, AN	6-9
Fittings, Brake Adapter	31
Fittings, Hose Ends	2-4
Fittings, Nitrous	17
Flexplates	27
Flexwrap	46
Float Bowl Washer	14
Front Motor Plates	35
Fuel Bowl Inlet Fitting	14
Fuel Bowl Sight Plugs	15
Fuel Cells	16
Fuel Filters	10, 11
Fuel Fragrances	33
Fuel Line	9
Fuel Pressure Regulators	11, 13
Fuel Pump Block Off Pate	10
Fuel Pump Mounting Plate	10
Fuel Pump Pushrod	11
Fuel Pumps	10, 11
Fuel Solenoid Bracket	16
Funnel	39

G

Gaskets	12, 14, 40-41, 54
Gauge Mounting Cups	20
Gauge Panel	20
Gauge Supply Line	20
Gauges	18-20
Guide Plates	37

H

Head Bolt Kits	37
Heat Protection Wrap	39
HEI Advance Curve Kit	46
HEI H.O. Tune-up Kit	46

H, cont.

HEI Pigtail Harness	45
HEI Vacuum Advance Lockout	45
Hood Pin Kit	25
Hood Pin Lanyards	25
Hood Springs	25
Hose Assembly Tools	3, 4
Hose Pressure Test Kit	9
Hose, Flex Fuel	4
Hose, Flex-Loc	5
Hose, Nitrous	16
Hose, Nylon	5
Hose, Stainless Steel	5
Hydraulic Roller Lifters	36

I

Ignition Coil	46
Insulated Clamps	9
Intake Manifold Bolts	37

L

Lifter Valley Vents	36
---------------------	----

M

Magnetic Drain Plug	35
Motor Mounts	36

N

Needle and Seat Assemblies	15
Nitrous Combo Wrench	17
Nitrous Distribution Blocks	17
Noise Protection Earmuffs	38

O

O2 Sensor Bung & Plug	54
Oil Breather Bottle	35
Oil Filler Cap	52
Oil Filter Adapter	35
Oil Pan	34
Oil Pan Bolts	35
Oil Pump Driveshafts	35
Oil Pump Primer	38
Oil Restrictor	35
One-Way Check Valves	9

P

Panel Fastener Springs	22
Panel Fasteners	22
Pilot Bushings	37
Piston Ring Compressors	38
Power Plus Lube	33

P, cont.

Power Steering Pump	53
Power Steering Pump Mount Kit	53
Power Steering Pump Pulleys	53
Power Valve	15
Power Valve Plug	14
Pressure Plate Bolts	37
Proportioning Valve	31
Push Button Switch	46

Q

Quarter-Turn Button Wrench	22
----------------------------	----

R

Racers Tape	21
Racing Seats	21
Radiator Cap	42
Radiator Fan Shrouds	42
Radiator Filler Neck	43
Radiator Flange Mounting Kit	43
Radiator Inlet/Outlet Kit	43
Radiator Mounting Kits	43
Radiator Outlet Fitting	42
Radiator Overflow Tank	44
Radiators	42
Rear End Girdles	28
Replacement Pins	25
Residual Valves	31
Ring and Pinion Install Kits	30
Ring and Pinion Sets	29-30
Ring Gear Spacers	28
Rivets	25
Rocker Arm Studs	37
Rod Bolt Stretch Gauge	38
Roll Bar Padding	21

S

Safety Wire & Pliers	38
Scuff Plates	25
Seat Riser Bracket	21
Silicone Hose Couplers	17
Slider Seat Track	21
Spark Plug Boot Protectors	39
Spark Plug Wire Divider	46
Spools	28
Starter Bolt Set	48
Starters	48-49
Storage Bags	38
Switches	46, 48, 50

T

T-bar Wing Nuts	53
T-Bolt Clamps	17

T, cont.

Thermal Tape	39
Throttle Cable	16
Throttle Mounting Bracket	16
Throttle Return Springs	14
Timing Chain Cover Bolts	35
Timing Chain Covers	35
Timing Pointers	36
Timing Tape	37
Tire Pressure Gauge	32
Tire Softener	33
Tools, Wrench Set	3
Top Dead Center Locator	38
Torque Converters	26
Trackbite	33
Transmission Oil Coolers	44

U

Under Body Washers	21
Utility Jugs	39

V

Vacuum Advance	45
Vacuum Cap Kit	15
Vacuum Reserve Canister	53
Vacuum Secondary Diaphragm	14
Vacuum Secondary Springs	14
Valve Cover Baffle	53
Valve Cover Bolt Kit	53
Valve Cover Mini-tabs	53
Valve Cover Spreader Bars	53
Valve Covers	51-52

W

Washers, Teflon	7
Water Outlets	44
Water Pump	44
Weld Fastener Plates	22
Welding Bungs	9
Wheel Rim Screws	32
Wheel Spacers	32
Wheel Studs	32
Wheel Valve Stems & Caps	32
Wheelie Bar Chalk	33
Wheelie-Bar Wheels	31
Wiring Harness	47

PART NUMBER INDEX

BEP10000	9	BEP10800	12	BEP12189	8	BEP12688	8	BEP13408	4
BEP10001	9	BEP10802	12	BEP12200	2	BEP12690	2	BEP13411	4
BEP10002	9	BEP10805	12	BEP12202	2	BEP12692	8	BEP13412	4
BEP10050	10	BEP10808	12	BEP12204	3	BEP12696	6	BEP13413	4
BEP10051	10	BEP10816	12	BEP12214	6	BEP12701	8	BEP13451	4
BEP10055	10	BEP10817	12	BEP12215	7	BEP12702	8	BEP13452	4
BEP10060	10	BEP10823	12	BEP12216	6	BEP12706	8	BEP13453	4
BEP10061	10	BEP10850	12	BEP12222	8	BEP12708	8	BEP13456	4
BEP10062	10	BEP10851	12	BEP12223	8	BEP12721	8	BEP13457	4
BEP10063	10	BEP10852	12	BEP12229	6	BEP12722	8	BEP13458	4
BEP10065	10	BEP10853	12	BEP12245	2	BEP12766	8	BEP13461	4
BEP10066	10	BEP10860	12	BEP12280	3	BEP12768	8	BEP13462	4
BEP10067	10	BEP10861	12	BEP12290	2	BEP12781	8	BEP13463	4
BEP10068	10	BEP10862	12	BEP12292	8	BEP12786	8	BEP13502	4
BEP10100	10	BEP10863	12	BEP12296	6	BEP12788	8	BEP13504	4
BEP10101	11	BEP10864	12	BEP12300	7	BEP12800	2	BEP13507	4
BEP10105	10	BEP10865	12	BEP12302	7	BEP12802	2	BEP13509	4
BEP10110	10	BEP10875	12	BEP12306	7	BEP12804	3	BEP13512	4
BEP10115	10	BEP10876	12	BEP12308	7	BEP12810	10	BEP13514	4
BEP10120	10	BEP10877	12	BEP12310	7	BEP12811	10	BEP13610	5
BEP10125	10	BEP10878	12	BEP12315	7	BEP12814	6	BEP13620	5
BEP10130	11	BEP10950	13	BEP12320	7	BEP12815	7	BEP13621	5
BEP10135	11	BEP10951	13	BEP12325	7	BEP12816	6	BEP13622	5
BEP10140	11	BEP10955	13	BEP12330	7	BEP12818	7	BEP13810	5
BEP10150	11	BEP11000	12	BEP12331	7	BEP12819	7	BEP13820	5
BEP10155	11	BEP11030	14	BEP12332	7	BEP12822	8	BEP13821	5
BEP10160	11	BEP11035	14	BEP12333	7	BEP12823	8	BEP13822	5
BEP10165	11	BEP11041	14	BEP12340	7	BEP12829	6	BEP14000	2
BEP10175	13	BEP11046	16	BEP12341	7	BEP12845	2	BEP14002	2
BEP10176	13	BEP11047	16	BEP12342	7	BEP12880	3	BEP14004	3
BEP10180	11	BEP11075	11	BEP12343	7	BEP12881	8	BEP14014	6
BEP10185	11	BEP11076	11	BEP12350	9	BEP12882	8	BEP14015	7
BEP10200	14	BEP11077	11	BEP12351	9	BEP12886	6	BEP14016	6
BEP10201	14	BEP11078	11	BEP12352	9	BEP12888	8	BEP14018	7
BEP10205	14	BEP11080	15	BEP12353	9	BEP12890	2	BEP14019	7
BEP10206	14	BEP11085	10	BEP12354	9	BEP12892	8	BEP14022	8
BEP10210	14	BEP11205	16	BEP12356	9	BEP12896	6	BEP14023	8
BEP10211	14	BEP11210	16	BEP12441	8	BEP12900	10	BEP14029	6
BEP10215	14	BEP12000	2	BEP12500	2	BEP12901	10	BEP14045	2
BEP10216	14	BEP12002	2	BEP12502	2	BEP12902	9	BEP14080	3
BEP10220	14	BEP12004	3	BEP12504	3	BEP12910	10	BEP14086	6
BEP10223	14	BEP12014	6	BEP12512	7	BEP12911	10	BEP14090	2
BEP10225	14	BEP12015	7	BEP12514	7	BEP12912	10	BEP14092	8
BEP10228	14	BEP12016	6	BEP12518	7	BEP12922	9	BEP14100	
BEP10230	14	BEP12018	7	BEP12534	7	BEP12960	10	10	
BEP10235	14	BEP12019	7	BEP12538	7	BEP12961	10	BEP14102	6
BEP10240	15	BEP12022	8	BEP12545	2	BEP12962	9	BEP14104	6
BEP10242	15	BEP12023	8	BEP12550	9	BEP12980	10	BEP14105	6
BEP10245	15	BEP12029	6	BEP12551	9	BEP12981	10	BEP14107	6
BEP10247	15	BEP12045	2	BEP12552	9	BEP12982	9	BEP14109	6
BEP10250	15	BEP12080	3	BEP12553	9	BEP13010	5	BEP14110	
BEP10255	14	BEP12086	6	BEP12554	9	BEP13020	5	10	
BEP10258	14	BEP12090	2	BEP12560	9	BEP13021	5	BEP14112	6
BEP10260	14	BEP12092	8	BEP12561	9	BEP13022	5	BEP14113	6
BEP10270	15	BEP12100	10	BEP12562	9	BEP13105	5	BEP14114	6
BEP10280	15	BEP12110	10	BEP12563	9	BEP13110	5	BEP14115	6
BEP10281	15	BEP12112	6	BEP12564	9	BEP13115	5	BEP14116	6
BEP10282	15	BEP12113	6	BEP12580	3	BEP13130	5	BEP14117	6
BEP10285	15	BEP12114	6	BEP12590	2	BEP13135	5	BEP14118	6
BEP10290	15	BEP12115	6	BEP12600	2	BEP13140	5	BEP14119	6
BEP10291	15	BEP12116	6	BEP12602	2	BEP13155	5	BEP14120	8
BEP10292	15	BEP12117	6	BEP12604	3	BEP13160	5	BEP14121	8
BEP10293	15	BEP12118	6	BEP12614	6	BEP13165	5	BEP14130	8
BEP10294	15	BEP12119	6	BEP12615	7	BEP13180	5	BEP14131	8
BEP10295	15	BEP12120	8	BEP12616	6	BEP13185	5	BEP14140	8
BEP10296	15	BEP12121	8	BEP12618	7	BEP13190	5	BEP14141	8
BEP10500	12	BEP12130	8	BEP12619	7	BEP13210	5	BEP14142	8
BEP10501	12	BEP12131	8	BEP12622	8	BEP13220	5	BEP14167	8
BEP10502	12	BEP12140	8	BEP12623	8	BEP13221	5	BEP14168	8
BEP10505	12	BEP12141	8	BEP12629	6	BEP13222	5	BEP14169	8
BEP10506	12	BEP12142	8	BEP12645	2	BEP13310	5	BEP14187	8
BEP10507	12	BEP12167	8	BEP12661	8	BEP13401	4	BEP14188	8
BEP10510	12	BEP12168	8	BEP12676	6	BEP13402	4	BEP14189	8
BEP10511	12	BEP12169	8	BEP12680	3	BEP13403	4	BEP14200	2
BEP10515	12	BEP12187	8	BEP12682	8	BEP13406	4	BEP14202	2
BEP10516	12	BEP12188	8	BEP12686	6	BEP13407	4	BEP14204	3

BEP14214	6	BEP14706	8	BEP15081	20	BEP17146	33	BEP22040	31
BEP14215	7	BEP14708	8	BEP15082	20	BEP17147	33	BEP22041	31
BEP14216	6	BEP14721	8	BEP15083	20	BEP17148	33	BEP22050	31
BEP14222	8	BEP14722	8	BEP15090	20	BEP17149	33	BEP22060	31
BEP14223	8	BEP14766	8	BEP15091	20	BEP17150	33	BEP22061	31
BEP14229	6	BEP14768	8	BEP15100	20	BEP17152	33	BEP22070	31
BEP14245	2	BEP14781	8	BEP15101	20	BEP17153	33	BEP22071	31
BEP14280	3	BEP14786	8	BEP15102	20	BEP17171	33	BEP22072	31
BEP14290	2	BEP14788	8	BEP15105	20	BEP20000	31	BEP22100	32
BEP14292	8	BEP14800	2	BEP15110	20	BEP20005	31	BEP22101	32
BEP14296	6	BEP14802	2	BEP15120	20	BEP20007	31	BEP22102	32
BEP14300	7	BEP14804	3	BEP15121	20	BEP20010	31	BEP22103	32
BEP14302	7	BEP14810	10	BEP15122	20	BEP20012	31	BEP24002	25
BEP14306	7	BEP14811	10	BEP15151	32	BEP20110	32	BEP24004	25
BEP14308	7	BEP14814	6	BEP15152	32	BEP20200	32	BEP24006	25
BEP14310	7	BEP14815	7	BEP15153	32	BEP20201	32	BEP24008	25
BEP14315	7	BEP14816	6	BEP15200	18	BEP20220	32	BEP24010	25
BEP14320	7	BEP14818	7	BEP15201	18	BEP20320	32	BEP24012	25
BEP14325	7	BEP14819	7	BEP15202	18	BEP20322	32	BEP24014	25
BEP14330	7	BEP14822	8	BEP15203	18	BEP20360	32	BEP24020	25
BEP14331	7	BEP14823	8	BEP15204	18	BEP20362	32	BEP24022	25
BEP14332	7	BEP14829	6	BEP15205	18	BEP20364	32	BEP24024	25
BEP14333	7	BEP14845	2	BEP15206	18	BEP20366	32	BEP24026	25
BEP14340	7	BEP14880	3	BEP15210	18	BEP20372	32	BEP24028	25
BEP14341	7	BEP14881	8	BEP15211	18	BEP20400	33	BEP24030	25
BEP14342	7	BEP14882	8	BEP15212	18	BEP20420	33	BEP24032	25
BEP14343	7	BEP14886	6	BEP15213	18	BEP20425	33	BEP24042	25
BEP14350	9	BEP14888	8	BEP15214	18	BEP20430	33	BEP24044	25
BEP14351	9	BEP14890	2	BEP15215	18	BEP20555	53	BEP24050	25
BEP14352	9	BEP14892	8	BEP15216	18	BEP21009	31	BEP24060	25
BEP14353	9	BEP14896	6	BEP16000	13	BEP21012	31	BEP24062	25
BEP14354	9	BEP14902	9	BEP16001	13	BEP21015	31	BEP24070	25
BEP14356	9	BEP14922	9	BEP16002	13	BEP21018	31	BEP24071	25
BEP14360	9	BEP14950	9	BEP16003	13	BEP21020	31	BEP24080	25
BEP14390	7	BEP14960	10	BEP16004	13	BEP21024	31	BEP24081	25
BEP14391	7	BEP14962	9	BEP16010	13	BEP21030	31	BEP24082	25
BEP14392	7	BEP14980	10	BEP16011	13	BEP21036	31	BEP24083	25
BEP14393	7	BEP14982	9	BEP16012	13	BEP21109	31	BEP24084	25
BEP14395	7	BEP15000	18	BEP16013	13	BEP21112	31	BEP24085	25
BEP14396	7	BEP15001	18	BEP16014	13	BEP21115	31	BEP24088	25
BEP14397	7	BEP15002	18	BEP16020	13	BEP21118	31	BEP25000	21
BEP14398	7	BEP15015	20	BEP16021	13	BEP21120	31	BEP25001	21
BEP14500	2	BEP15016	19	BEP16030	13	BEP21124	31	BEP25002	21
BEP14502	2	BEP15017	19	BEP16031	13	BEP21130	31	BEP25100	21
BEP14504	3	BEP15018	19	BEP16050	15	BEP21136	31	BEP25150	21
BEP14512	7	BEP15019	19	BEP16051	15	BEP21142	31	BEP25300	21
BEP14514	7	BEP15020	19	BEP16055	15	BEP21209	31	BEP25350	21
BEP14518	7	BEP15021	19	BEP16056	15	BEP21212	31	BEP26000	25
BEP14534	7	BEP15022	19	BEP16100	16	BEP21215	31	BEP26005	25
BEP14538	7	BEP15023	19	BEP16101	16	BEP21218	31	BEP26010	25
BEP14545	2	BEP15024	19	BEP16105	16	BEP21221	31	BEP26012	25
BEP14580	3	BEP15025	19	BEP16110	16	BEP21224	31	BEP26015	25
BEP14590	2	BEP15026	19	BEP16111	16	BEP21230	31	BEP26025	25
BEP14600	2	BEP15027	19	BEP16115	16	BEP21236	31	BEP26030	25
BEP14602	2	BEP15028	19	BEP16200	16	BEP21242	31	BEP26031	25
BEP14604	3	BEP15029	19	BEP16210	16	BEP21248	31	BEP26100	22
BEP14614	6	BEP15030	19	BEP16300	13	BEP21309	31	BEP26103	22
BEP14615	7	BEP15031	19	BEP16301	13	BEP21312	31	BEP26106	22
BEP14616	6	BEP15032	19	BEP16302	13	BEP21315	31	BEP26109	22
BEP14618	7	BEP15033	19	BEP16310	13	BEP21318	31	BEP26130	22
BEP14619	7	BEP15034	19	BEP16311	13	BEP21321	31	BEP26133	22
BEP14622	8	BEP15040	20	BEP16312	13	BEP21324	31	BEP26200	22
BEP14623	8	BEP15041	20	BEP17018	33	BEP21330	31	BEP26205	22
BEP14629	6	BEP15042	20	BEP17031	33	BEP21336	31	BEP26225	22
BEP14645	2	BEP15043	20	BEP17035	33	BEP21342	31	BEP26231	22
BEP14661	8	BEP15045	19	BEP17037	33	BEP22000	31	BEP26270	22
BEP14676	6	BEP15046	19	BEP17038	33	BEP22001	31	BEP26274	22
BEP14680	3	BEP15047	19	BEP17119	33	BEP22002	31	BEP26278	22
BEP14682	8	BEP15048	19	BEP17132	33	BEP22010	31	BEP26281	22
BEP14686	6	BEP15051	20	BEP17136	33	BEP22011	31	BEP26320	22
BEP14688	8	BEP15052	20	BEP17139	33	BEP22012	31	BEP26324	22
BEP14690	2	BEP15053	20	BEP17141	33	BEP22020	31	BEP26327	22
BEP14692	8	BEP15054	20	BEP17142	33	BEP22021	31	BEP26330	22
BEP14696	6	BEP15055	20	BEP17143	33	BEP22022	31	BEP26340	22
BEP14701	8	BEP15056	20	BEP17144	33	BEP22025	31	BEP26346	22
BEP14702	8	BEP15080	20	BEP17145	33	BEP22030	31		

BEP26374	22	BEP28230	24	BEP31001	28	BEP35052	16	BEP40031	38
BEP26382	22	BEP28232	24	BEP31001	29	BEP35053	16	BEP40100	39
BEP26400	22	BEP28234	24	BEP31003	28	BEP35055	16	BEP40101	39
BEP26406	22	BEP28238	24	BEP31003	29	BEP35057	16	BEP40102	39
BEP26412	22	BEP28244	24	BEP31006	28	BEP35058	16	BEP40110	39
BEP26440	22	BEP28246	24	BEP31006	29	BEP35101	16	BEP40115	39
BEP26447	22	BEP28250	24	BEP31020	28	BEP35110	16	BEP40120	39
BEP26450	22	BEP28254	24	BEP31020	30	BEP35111	16	BEP40121	39
BEP26454	22	BEP28256	24	BEP31023	28	BEP35112	16	BEP41013	38
BEP26468	22	BEP28258	24	BEP31023	29	BEP35500	17	BEP41014	38
BEP26476	22	BEP28260	24	BEP31024	28	BEP35501	17	BEP41015	38
BEP26483	22	BEP28264	24	BEP31024	29	BEP35502	17	BEP41025	38
BEP26486	22	BEP29100	31	BEP31025	28	BEP35503	17	BEP41026	38
BEP26489	22	BEP29105	31	BEP31025	29	BEP35504	17	BEP41027	38
BEP27000	21	BEP29200	33	BEP31026	28	BEP35505	17	BEP41040	38
BEP27001	21	BEP29210	33	BEP31026	29	BEP35510	17	BEP41041	22
BEP27002	21	BEP29215	33	BEP31027	28	BEP35515	17	BEP41045	38
BEP27003	21	BEP29220	33	BEP31027	29	BEP37000	17	BEP41052	38
BEP27004	21	BEP29500	21	BEP31030	28	BEP37001	17	BEP41053	38
BEP27005	21	BEP29501	21	BEP31030	29	BEP37002	17	BEP41058	38
BEP27006	21	BEP29502	21	BEP31042	28	BEP37003	17	BEP41062	38
BEP27020	21	BEP29600	21	BEP31042	29	BEP37004	17	BEP41080	3
BEP27025	21	BEP29605	21	BEP31805	28	BEP37005	17	BEP41081	3
BEP27100	21	BEP29610	21	BEP31806	28	BEP37006	17	BEP41100	38
BEP27101	21	BEP29620	21	BEP31807	28	BEP37008	17	BEP41200	3
BEP27102	21	BEP29625	21	BEP31808	28	BEP37010	17	BEP41205	17
BEP27103	21	BEP29630	21	BEP31809	28	BEP37012	17	BEP41300	3
BEP27104	21	BEP30000	29	BEP31810	28	BEP37014	17	BEP41305	3
BEP27105	21	BEP30001	29	BEP31811	28	BEP37016	17	BEP41310	3
BEP27107	21	BEP30002	29	BEP31812	28	BEP38000	17	BEP41315	3
BEP28000	32	BEP30003	29	BEP31813	28	BEP38001	17	BEP41320	3
BEP28100	23	BEP30005	29	BEP31815	28	BEP38002	17	BEP41321	3
BEP28102	23	BEP30006	29	BEP31816	28	BEP38003	17	BEP41322	3
BEP28104	23	BEP30007	29	BEP32000	27	BEP38004	17	BEP41330	4
BEP28110	23	BEP30008	29	BEP32001	27	BEP38005	17	BEP42000	36
BEP28114	23	BEP30009	29	BEP32002	27	BEP38006	17	BEP42050	45
BEP28116	23	BEP30010	29	BEP32003	27	BEP38008	17	BEP42051	45
BEP28118	23	BEP30011	29	BEP32004	27	BEP38100	17	BEP42100	35
BEP28120	23	BEP30012	29	BEP32005	27	BEP38102	17	BEP42105	35
BEP28124	23	BEP30014	29	BEP32006	27	BEP38103	17	BEP43000	34
BEP28128	23	BEP30016	30	BEP32007	27	BEP38104	17	BEP43001	34
BEP28130	23	BEP30017	30	BEP32008	27	BEP38106	17	BEP43002	34
BEP28134	23	BEP30018	30	BEP32012	27	BEP38200	17	BEP43008	34
BEP28138	23	BEP30020	30	BEP32016	27	BEP38201	17	BEP43011	34
BEP28140	23	BEP30021	30	BEP32017	27	BEP38202	17	BEP43012	34
BEP28144	23	BEP30022	30	BEP32050	27	BEP38203	17	BEP43013	34
BEP28146	23	BEP30024	30	BEP32055	27	BEP38204	17	BEP43016	34
BEP28148	23	BEP30025	30	BEP32060	27	BEP38205	17	BEP43019	34
BEP28152	23	BEP30026	29	BEP32105	27	BEP38300	17	BEP43020	34
BEP28160	23	BEP30027	30	BEP32110	27	BEP38301	17	BEP43025	35
BEP28162	23	BEP30040	29	BEP34000	27	BEP38302	17	BEP43040	34
BEP28168	23	BEP30045	29	BEP34001	27	BEP38303	17	BEP43041	34
BEP28172	23	BEP30050	29	BEP34002	27	BEP38304	17	BEP43090	38
BEP28174	23	BEP30052	29	BEP34003	27	BEP38305	17	BEP43095	38
BEP28176	23	BEP30054	29	BEP34004	27	BEP38400	17	BEP43120	35
BEP28178	23	BEP30100	30	BEP34005	27	BEP38401	17	BEP43125	35
BEP28184	23	BEP30100	30	BEP34006	27	BEP38402	17	BEP43150	35
BEP28186	23	BEP30100	30	BEP34007	27	BEP38403	17	BEP43500	33
BEP28188	23	BEP30105	29	BEP34008	27	BEP38405	17	BEP44000	34
BEP28190	24	BEP30105	30	BEP35000	16	BEP38406	17	BEP44005	34
BEP28200	24	BEP30105	30	BEP35001	16	BEP38408	17	BEP44010	34
BEP28202	24	BEP30115	30	BEP35002	16	BEP38410	17	BEP44015	34
BEP28204	24	BEP30115	30	BEP35003	16	BEP38500	17	BEP44100	34
BEP28206	24	BEP30117	30	BEP35010	16	BEP38503	17	BEP44105	34
BEP28208	24	BEP30120	29	BEP35011	16	BEP38505	17	BEP44110	34
BEP28210	24	BEP30120	30	BEP35012	16	BEP40001	38	BEP44200	34
BEP28212	24	BEP30120	30	BEP35013	16	BEP40002	38	BEP44205	34
BEP28214	24	BEP30125	29	BEP35014	16	BEP40009	38	BEP44210	34
BEP28216	24	BEP30125	30	BEP35015	16	BEP40020	38	BEP44215	34
BEP28218	24	BEP30125	30	BEP35016	16	BEP40021	38	BEP44250	35
BEP28220	24	BEP30127	29	BEP35019	16	BEP40022	38	BEP44255	35
BEP28222	24	BEP30127	30	BEP35020	16	BEP40023	38	BEP45000	36
BEP28224	24	BEP30127	30	BEP35021	16	BEP40025	38	BEP45005	36
BEP28226	24	BEP30130	30	BEP35023	16	BEP40026	38	BEP45010	36
BEP28228	24	BEP31000	28	BEP35050	16	BEP40027	38	BEP47050	37
		BEP31000	30	BEP35051	16	BEP40029	38	BEP47056	37

BEP47059	37	BEP50002	48	BEP55044	46	BEP60572	42	BEP70402	36
BEP47100	52	BEP50003	49	BEP55050	46	BEP60573	42	BEP70403	36
BEP47101	52	BEP50004	48	BEP55087	45	BEP60574	42	BEP70408	36
BEP47300	37	BEP50009	49	BEP55091	45	BEP60575	42	BEP70410	36
BEP47320	35	BEP50013	49	BEP55092	45	BEP60576	42	BEP70412	36
BEP47330	34	BEP50017	49	BEP55100	45	BEP60577	42	BEP70414	36
BEP47330	35	BEP50018	49	BEP55101	45	BEP60585	42	BEP70415	36
BEP47350	37	BEP50020	48	BEP55102	45	BEP60700	33	BEP70418	36
BEP47355	37	BEP50023	48	BEP55103	45	BEP65000	9	BEP70420	36
BEP47400	36	BEP50025	48	BEP55110	46	BEP65001	9	BEP70430	37
BEP47405	36	BEP50030	50	BEP56000	46	BEP65002	9	BEP70431	37
BEP47410	36	BEP50031	50	BEP56001	46	BEP65003	9	BEP70432	37
BEP47420	36	BEP50032	50	BEP56002	46	BEP65004	9	BEP70433	37
BEP47425	36	BEP50035	50	BEP56003	46	BEP65005	9	BEP70434	37
BEP47515	37	BEP50036	50	BEP56004	46	BEP65100	15	BEP70500	51
BEP47520	37	BEP50040	50	BEP56005	46	BEP65105	15	BEP70501	51
BEP47525	37	BEP50041	50	BEP56006	46	BEP65110	15	BEP70502	51
BEP47530	37	BEP50044	50	BEP58100	50	BEP65150	35	BEP70510	51
BEP47540	37	BEP50045	50	BEP58110	50	BEP65150	35	BEP70511	51
BEP47550	37	BEP50050	50	BEP60000	43	BEP65200	32	BEP70512	51
BEP47551	37	BEP50051	50	BEP60005	43	BEP70010	51	BEP70515	51
BEP47555	37	BEP50055	50	BEP60010	43	BEP70011	51	BEP70516	51
BEP47556	37	BEP50060	49	BEP60011	43	BEP70012	51	BEP70520	51
BEP47560	37	BEP50064	48	BEP60015	43	BEP70015	51	BEP70521	51
BEP47565	37	BEP50070	50	BEP60016	43	BEP70017	51	BEP70522	51
BEP47570	37	BEP50071	50	BEP60018	43	BEP70019	51	BEP70526	51
BEP47575	37	BEP50072	50	BEP60020	43	BEP70030	51	BEP70527	51
BEP48000	35	BEP50075	50	BEP60022	43	BEP70032	51	BEP80060	54
BEP48011	37	BEP50076	50	BEP60025	43	BEP70033	51	BEP80065	54
BEP48012	37	BEP50077	50	BEP60040	43	BEP70034	51	BEP80080	54
BEP48015	37	BEP50131	54	BEP60041	43	BEP70035	51	BEP80082	54
BEP48020	37	BEP50140	54	BEP60042	43	BEP70036	52	BEP80084	54
BEP48021	37	BEP50145	54	BEP60043	43	BEP70037	52	BEP80100	39
BEP48050	37	BEP50150	53	BEP60044	43	BEP70038	51	BEP80103	39
BEP48055	37	BEP50155	53	BEP60050	44	BEP70039	51	BEP80104	39
BEP48100	36	BEP50160	53	BEP60055	44	BEP70041	51	BEP80105	39
BEP48105	36	BEP50165	53	BEP60057	44	BEP70081	35	BEP80106	39
BEP48200	36	BEP52000	46	BEP60060	44	BEP70082	35	BEP80107	39
BEP48205	36	BEP52005	46	BEP60062	44	BEP70083	35	BEP80108	39
BEP48210	36	BEP52007	47	BEP60070	44	BEP70123	52	BEP80109	39
BEP48220	36	BEP52008	47	BEP60075	44	BEP70124	52	BEP80110	39
BEP48300	35	BEP52010	47	BEP60077	44	BEP70125	52	BEP80115	39
BEP48315	36	BEP52015	46	BEP60080	43	BEP70133	52	BEP80120	39
BEP48500	53	BEP52020	47	BEP60085	43	BEP70134	53	BEP80122	39
BEP48505	53	BEP52021	47	BEP60120	44	BEP70135	52	BEP80124	39
BEP49100	40	BEP52022	47	BEP60121	44	BEP70136	52	BEP80126	39
BEP49105	40	BEP52023	47	BEP60122	44	BEP70137	52	BEP81001	54
BEP49110	40	BEP52024	47	BEP60126	44	BEP70138	52	BEP81006	54
BEP49115	40	BEP52025	47	BEP60295	53	BEP70139	52	BEP81011	54
BEP49130	40	BEP52050	46	BEP60296	53	BEP70140	52	BEP82300	54
BEP49150	40	BEP52060	50	BEP60300	44	BEP70140	52	BEP82302	54
BEP49200	40	BEP52061	50	BEP60305	44	BEP70141	52	BEP82304	54
BEP49205	40	BEP52063	50	BEP60350	44	BEP70142	52	BEP82305	54
BEP49230	40	BEP52100	47	BEP60401	44	BEP70143	52	BEP82320	54
BEP49300	40	BEP54000	47	BEP60402	44	BEP70144	53	BEP82322	54
BEP49305	40	BEP54001	47	BEP60403	44	BEP70145	35	BEP82324	54
BEP49400	41	BEP54002	47	BEP60404	44	BEP70150	53	BEP82340	54
BEP49405	41	BEP54003	47	BEP60420	44	BEP70170	53	BEP82350	54
BEP49410	41	BEP54020	47	BEP60425	44	BEP70171	53	BEP82352	54
BEP49418	41	BEP54021	47	BEP60522	42	BEP70172	53	BEP82354	54
BEP49430	41	BEP54022	47	BEP60524	42	BEP70173	53	BEP82360	54
BEP49435	41	BEP54030	47	BEP60526	42	BEP70190	53	BEP82364	54
BEP49438	41	BEP54031	47	BEP60528	42	BEP70193	53	BEP82366	54
BEP49455	41	BEP54040	47	BEP60550	43	BEP70195	53	BEP82380	54
BEP49458	41	BEP54100	47	BEP60551	43	BEP70300	52	BEP82386	54
BEP49500	41	BEP54105	45	BEP60552	42	BEP70320	52	BEP82390	54
BEP49505	41	BEP54106	45	BEP60555	43	BEP70325	52	BEP82500	54
BEP49530	41	BEP54110	50	BEP60556	43	BEP70330	52	BEP82505	54
BEP49535	41	BEP54200	50	BEP60557	43	BEP70335	52		
BEP49600	41	BEP54210	50	BEP60560	43	BEP70340	52		
BEP49605	10	BEP55001	45	BEP60564	42	BEP70350	53		
BEP49605	40	BEP55008	45	BEP60565	42	BEP70351	53		
BEP49610	10	BEP55013	15	BEP60566	42	BEP70355	53		
BEP49610	40	BEP55015	45	BEP60567	42	BEP70360	36		
BEP49615	41	BEP55025	46	BEP60570	42	BEP70400	36		
BEP50000	49	BEP55043	46	BEP60571	42	BEP70401	36		



Choose The Gear Ratio That Is Best For Your Vehicle

When selecting a Gear Ratio, you should consider the following:

1. Tire Size
2. Transmission Ratio
3. Final Gear Ratio
4. Engine RPM at Cruise Speed

The following formula has been developed to calculate the optimum final Gear Ratio to suit your application.

$$\frac{\text{M.P.H. X Gear Ratio}}{\text{Tire Diameter}} \times 336 = \text{rpm}$$

The chart shown below shows RPM calculations at 55 MPH for various combinations of final Gear Ratio and Tire Diameter.

According to this chart, the **acceptable** RPM range is 2000-3000 which is represented by the entire shaded area of the chart. The **optimum** RPM range is 2300-2600, and it is represented by the white area between the two red areas. When changing ratios to **improve mileage**, choose a ratio within the red shaded band **above** the optimum range. When changing ratios to **improve power**, choose a ratio within the red shaded band **below** the optimum range.

Gear Ratio	Tire Diameter																
	24	25	26	27	28	29	30	31	32	33	34	35	36	38	40	42	44
2.56	1972	1892	1820	1752	1690	1631	1577	1526	1478	1434	1391	1352	1314	1245	1183	1126	1075
2.73	2102	2018	1940	1869	1802	1740	1682	1627	1577	1529	1484	1441	1401	1328	1261	1201	1147
2.94	2264	2173	2090	2012	1942	1874	1811	1753	1698	1646	1599	1552	1509	1429	1358	1294	1235
3.08	2372	2277	2189	2108	2033	1963	1897	1836	1779	1725	1674	1626	1581	1498	1423	1355	1294
3.21	2472	2373	2282	2197	2119	2046	1977	1914	1854	1798	1745	1695	1648	1561	1483	1412	1348
3.31	2549	2447	2353	2266	2185	2110	2039	1973	1912	1854	1799	1748	1699	1610	1529	1456	1390
3.42	2633	2528	2430	2341	2257	2179	2107	2039	1975	1915	1859	1806	1756	1663	1580	1505	1436
3.54	2726	2617	2516	2423	2336	2256	2181	2110	2044	1982	1924	1869	1817	1722	1635	1558	1487
3.73	2872	2757	2651	2553	2462	2377	2298	2224	2154	2088	2027	1969	1915	1814	1723	1641	1567
3.90	3008	2883	2772	2679	2574	2485	2402	2325	2252	2184	2120	2059	2002	1897	1802	1716	1638
4.10	3157	3031	2914	2806	2706	2613	2526	2444	2368	2296	2228	2165	2106	1994	1894	1804	1722
4.27	3288	3156	3030	2928	2810	2721	2630	2545	2466	2391	2321	2255	2192	2077	1973	1879	1793
4.56	3511	3371	3291	3121	3010	2900	2800	2718	2633	2554	2478	2408	2341	2218	2107	2006	1915
4.88	3758	3607	3469	3340	3221	3110	3000	2900	2818	2733	2652	2577	2505	2373	2250	2147	2060
5.29	4073	3910	3760	3621	3491	3371	3259	3154	3055	2962	2875	2798	2716	2573	2444	2328	2222
5.38	4143	3977	3824	3682	3551	3428	3314	3207	3107	3015	2924	2841	2762	2616	2486	2367	2260
5.71	4397	4221	4058	3908	3769	3639	3517	3404	3298	3198	3104	3015	2934	2777	2638	2512	2398
6.17	4751	4561	4385	4223	4072	3932	3801	3678	3563	3455	3354	3258	3167	3001	2851	2715	2591
7.17	5521	5300	5096	4907	4732	4569	4417	4274	4141	4015	3897	3786	3681	3487	3313	3155	3011

SOME OF THE PARTS LISTED IN THIS CATALOG ARE NOT MANUFACTURED BY THE ORIGINAL EQUIPMENT MANUFACTURER AND ANY REFERENCE TO TRADEMARKS ARE FOR CROSS REFERENCE PURPOSES ONLY. NO REPRESENTATION IS MADE WITH RESPECT TO THE SOURCE OF MANUFACTURE OF ANY PARTICULAR PART.