

CFR

PERFORMANCE



CATALOG 7

ADS
Accessory Drive Systems

Black-tie
Electro Deposit Primer

EMC
Evolution Modular Cooling

R.F.C.
Retro Finned Collection

It's all about
Character



CFR Performance is a major automotive supplier and distributor of car and truck accessories. We are part of a family owned and operated tradition of automotive excellency, which dates back to the late 1970's. Since then we have put together some new and innovative products to provide for our customers. At CFR, we use our long tradition of wisdom in automotive business and customer satisfaction to provide you with superior quality and cost effective products.

Over the years, our product line has grown to more than 3000 part numbers and is constantly growing. We are entirely customer focused, shipping most stock orders within twenty-four hours. Our mission at CFR Performance is to provide the highest innovative quality performance products to our customers at competitive pricing without lowering our company standards.



TABLE OF CONTENTS



ADS Kits 4-5



LS Parts 6-8



Featured Series 9



Air Cleaners/Accessories 10-19



Valve Covers 20-38



Valve Covers/Dress Up Kits 39-41



Timing Chain/Accessories 42-43



Oil Pan Accessories 44-66



Flywheel Covers & Transmission pans 67-69



Dipsticks 70-72



Pulleys & Pulley kits 73-80



Brackets & Accessories 81-85



Radiators & Accessories 86-93



Cooling 94-97



Distributors 98



Ignition Accessories 98



Transmission/Throttle Cable Kits, Fuel Lines & Block Plates 99



Alternators, Starters & Master Cylinder Covers 100



Power Steering Pumps & Power Steering Overflow Tanks 101



Interior Dress up Accessories 102-104



Battery Trays & Hood Pins 105



Body Parts 106



Headers 107-109

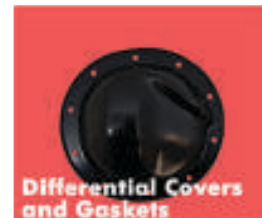

Differential Covers and Gaskets 110-115



Hardware Bolts / Washers 116

Notes	117
Payment, Return, Warranty	118
Index	119

ADS
Accessory Drive Systems

The CFR Performance Accessory Drive System is the first economical complete engine front drive kit to be offered on the market. Accessory Drive Systems are engineered to fit correctly. Available for a V-Belt setup and Serpentine

V BELT KITS

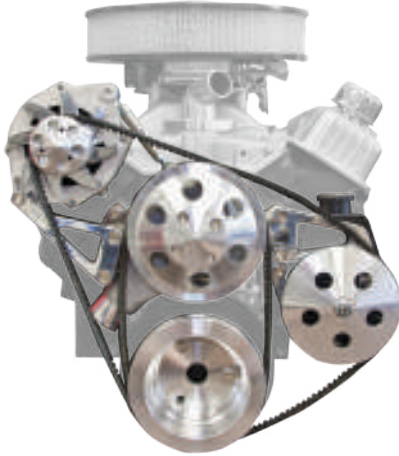

Small Block Chevy 283-400
ADS-3911-C Chrome
ADS-3911-PBK Black
ADS-3911-M Machined
ADS-3911-POL Polished
 Will not fit LT1 engines and ZZ4 383 crate engine



Small Block Chevy - Steel 283-400
**** ADS-3911-S-C-KIT** Chrome
**** ADS-3911-S-PBK-KIT** Black
ADS-3911-S-C-KIT-AIR Chrome
ADS-3911-S-PBK-KIT-AIR Black

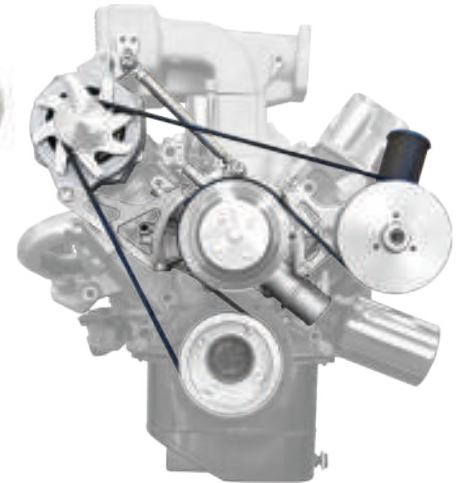

Ford Small Block 289-302
ADS-4300-C Chrome
ADS-4300-PBK Black
ADS-4300-M Machined
ADS-4300-POL Polished

SERPENTINE KITS

Serpentine Kit Includes:

- Aluminum Reverse Water Pump • 120 Amp, 1 wire Alternator
- SD-7 Peanut Style A/C Compressor • Aluminum Type II Power Steering Pump
- Belt Tensioner with Aluminum Cover • 6061-T6 Aluminum Pulleys with Protective Wear Coating
- 6061-T6 One Piece Billet Bracket • Gates 6-Groove Belt & Hardware
- Remote Power Steering Reservoir Tank • A/C Manifold



***Does Not Come With A/C**
Big Block Chevy 396-454
ADS-5215-C Chrome
ADS-5215-PBK Black
ADS-5215-M Machined
ADS-5215-POL Polished



***Does Not Come With A/C**
Small Block Chevy 283-400
ADS-5115-C Chrome
ADS-5115-PBK Black
ADS-5115-M Machined
ADS-5115-POL Polished



Big Block Chevy 348-409
ADS-5210-C Chrome
ADS-5210-PBK Black
ADS-5210-M Machined
ADS-5210-POL Polished

SERPENTINE KITS

ADS PULLEY KITS



Small Block Chevy
305-350-400

- ADS-5100-C** Chrome
- ADS-5100-PBK** Black
- ADS-5100-M** Machined
- ADS-5100-POL** Polished



Big Block Chevy
396-454

- ADS-5200-C** Chrome
- ADS-5200-PBK** Black
- ADS-5200-M** Machined
- ADS-5200-POL** Polished



Chevy LS
4.8L-5.3L-6.0L-6.2L

- ADS-5300-C** Chrome
- ADS-5300-PBK** Black
- ADS-5300-M** Machined
- ADS-5300-POL** Polished



Available in 3 or 4 bolt

Small Block Ford
289-302

- ADS-5400-C** Chrome
- ADS-5400-PBK** Black
- ADS-5400-M** Machined
- ADS-5400-POL** Polished



Available in 3 or 4 bolt

Big Block Ford FE
352-460

- ADS-5500-C** Chrome
- ADS-5500-PBK** Black
- ADS-5500-M** Machined
- ADS-5500-POL** Polished



Available in 3 or 4 bolt

Ford 351C
351C-400

- ADS-5600-C** Chrome
- ADS-5600-PBK** Black
- ADS-5600-M** Machined
- ADS-5600-POL** Polished



Mopar Big Block
383-440

- ADS-5700-C** Chrome
- ADS-5700-PBK** Black
- ADS-5700-M** Machined
- ADS-5700-POL** Polished



Pontiac
326-455

- ADS-5900-C** Chrome
- ADS-5900-PBK** Black
- ADS-5900-M** Machined
- ADS-5900-POL** Polished



Oldsmobile
307-455

- ADS-6000-C** Chrome
- ADS-6000-PBK** Black
- ADS-6000-M** Machined
- ADS-6000-POL** Polished

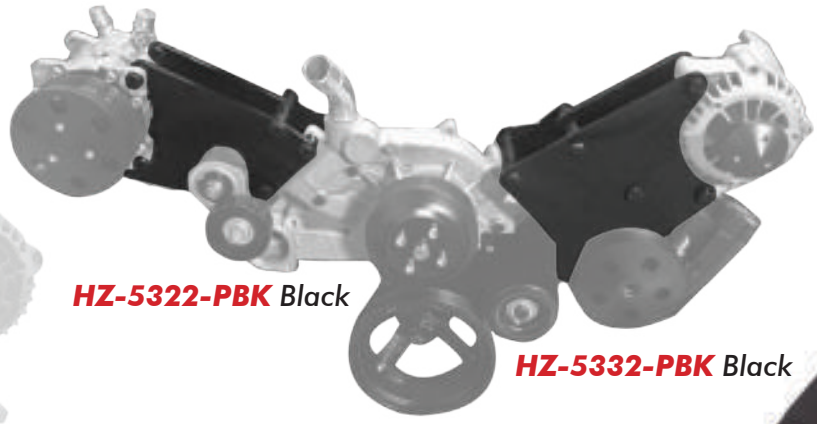

HZ-5322-PBK Black

HZ-5332-PBK Black

Designed for LS swaps, these relocation brackets allow for more space by raising the A/C compressor and power steering away from the frame.

All brackets include mounting hardware.

LS Alternator/ A-Can Style Power Steering Relocation Bracket Kit

**Does not Include Alternator or Power Steering Pump.
Note: must use Gates idler #38001**

HZ-5331-C Chrome
HZ-5331-PBK Black

LS Alternator/ Type 2 Style Power Steering Relocation Bracket Kit

**Does not Include Alternator or Power Steering Pump.
Note: must use Gates idler #38001**

HZ-5332-C Chrome
HZ-5332-PBK Black

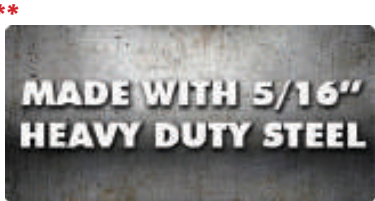

LS SD7 A/C Relocation Bracket Kit

**Steel sanden 508 style A/C relocation bracket
(Does not Include A/C or Tensioner
Note: must use Gates tensioner #38107)**

HZ-5321-C Chrome
HZ-5321-PBK Black



LS Sanden 508 A/C Relocation Bracket Kit

**Type 2 style Alternator / powersteering relocation bracket
(Does not Include A/C or Tensioner
Note: must use Gates tensioner #38107)**

HZ-5322-C Chrome
HZ-5322-PBK Black



Chevy LS Serpentine Kit

ADS-5300-C Chrome
ADS-5300-PBK Black
ADS-5300-M Machined
ADS-5300-POL Polished



Chevy LS Valve Covers

HZ-8005-PBK Black
HZ-8005-POL Polished
(W/O Coil Mounts)



Chevy LS Valve Cover Adapter

HZ-8000-PBK Black
HZ-8000-POL Polished



Chevy LS Valley Plate

HZ-8010-PBK Black
HZ-8010-POL Polished With Oil Fill Tube & Knock Sensor Tubes Gen I / II



HZ-8011-PBK Black
HZ-8011-POL Polished With Oil Filler Hole Gen III / IV



1999-2016 LS Valve Cover Gaskets
HZ-7998 Black



LS Cast Iron Manifold

HZ-9988-C Chrome
HZ-9988-CER-PBK Ceramic Black
HZ-9988-CER-SIL Ceramic Silver
HZ-9988-R Raw



Chevy LS Braided Throttle Cable 36"

CFR-6055 Natural
CFR-6055-PBK Black



ALUMINUM SPARK PLUG WIRE BOOT HEAT SHIELD PROTECTOR
CFR-3700-SIL Silver
CFR-3700-RED Red
CFR-3700-PBK Black
CFR-3700-PBL Blue

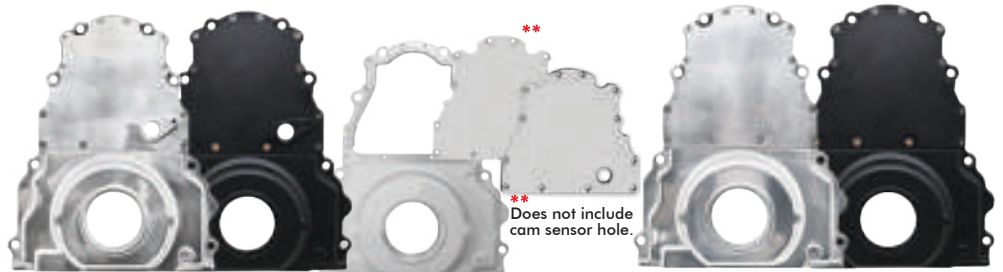

LS Timing Cover Two Piece
with Cam Sensor Hole

HZ-6008-PBK Black
HZ-6008-POL Polished

LS Timing Cover Two Piece
without Cam Sensor Hole

HZ-6009-PBK Black
HZ-6009-POL Polished



Chevy LS Truck Flexible Dipstick 18-1/8"
CFR-1998 Natural
CFR-1998-PBK Black



Chevy LS1 1997-Up Flexible Dipstick 17-1/8"
CFR-1999 Natural
CFR-1999-PBK Black



1967-69 CHEVY CAMARO
HZ-6769-AT-LS Natural
HZ-6769-AT-LS -POL Polished
HZ-6769-AT-LS -PBK Black



1968-77 CHEVY CHEVELLE A-BODY
HZ-6877-AT-LS Natural
HZ-6877-AT-LS -POL Polished
HZ-6877-AT-LS -PBK Black



1970-81 CHEVY CAMARO
HZ-7081-AT-LS Natural
HZ-7081-AT-LS -POL Polished



LS Water Neck Aluminum
HZ-6145-C Chrome
HZ-6145-PBK Black
HZ-6145-POL Polished



Chevy LS1, LS3, LS6
1999-2001 Oil Pan Gasket
HZ-7499



Straight Fitting
Chevy GM LS Oil Pan
HZ-9733-C Chrome **HZ-9733-PBK** Black
HZ-9733-R Raw **HZ-9733-Z** Zinc

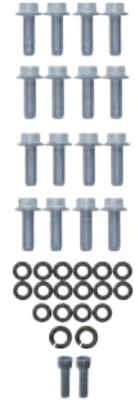

LS Oil Pan Bolt Kit
HZ-9906-KIT
HZ-9906-KIT-PBK Black



Angled Fitting
Chevy GM LS Oil Pan
HZ-9734-C Chrome **HZ-9734-PBK** Black
HZ-9734-R Raw **HZ-9734-Z** Zinc

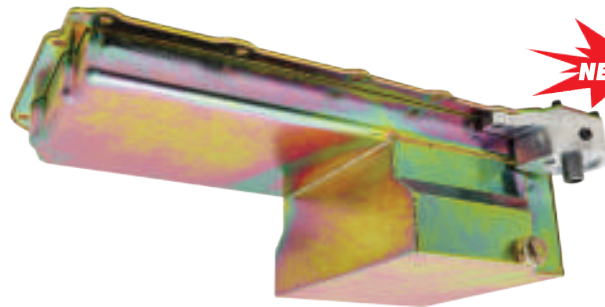

Chevy GM LS Oil Pan
HZ-9736-C Chrome **HZ-9736-PBK** Black
HZ-9736-R Raw **HZ-9736-Z** Zinc

Fits 1968-72 Nova, 1965-72 Chevelle, 1967-'69 Camaro, Can also be used on other applications check dimensions for clearance. Engine application: GM LS Series. Features wet sump, 7 quart capacity, 6" deep baffled trap-door baffling improving oil control and -10AN fittings for remote filter, uses stock dipstick



Chevy LS Oil Pump Pickup
HZ-9735-PBK Black

Black-tie

Electro Deposit Primer

EDP, is an electronically applied process, the electric current secures the paint solution to the metal and provides coverage to the entire part. EDP Provides a rust resistant coating and features OEM style satin black finish and is the perfect base for powder coating or custom painting.

EDP is compliant with HAPS (Hazardous Air Pollutants), VOCS (Volatile Organic Compounds), OSHA, ROHS and EPA.



14" - FLAT BASE
HZ-3195BOX-PBK Black
****HZ-3195BOX-W-PBK** Black
 **Comes with washable filter
 H: 3" W: 14" Neck: 5 1/8"



CHEVY SMALL BLOCK - OEM STYLE
 1958-86, 283-305-327-350-400 BAFFLED
HZ-9518-PBK Black
SHORT H: 2 5/8"



CHEVY SMALL BLOCK OEM OIL PAN
HZ-7006-PBK Black

New limited edition copper series brings a new process of copper plating to give that nice copper shine and to finish off the items get a clear coat sealant to protect against all elements maintaining that shine for years to come!

Copper

Limited Edition Copper Series

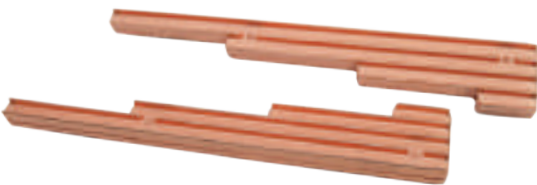

ALUMINUM WIRE LOOM KIT - FINNED
HZ-6061-3-COP Copper



15" - FULL FINNED
HZ-6021-3-COP Copper
 H: 3" W: 8 1/4" L: 15" Neck: 5 1/8"



ALUMINUM PUSH IN BREATHER FINNED
HZ-6119-COP Copper
DIA.: 2-3/8" FITS.: 1-1/4" TUBES.: 5/8"



ALUMINUM PUSH IN BREATHER FINNED - PCV
HZ-6120-COP Copper
DIA.: 2-3/8" FITS.: 1-1/4" TUBES.: 5/8"

Black Pearl

Black Chrome Edition

The new Black Pearl, black chrome edition we are bringing back an old school favorite! maintaining the richness of chrome and black together!



CHEVY SMALL BLOCK
 1958-86, 283-305-327-350-400
HZ-9516-BC Black Chrome
SHORT H: 2 5/8"
 BAFFLED



14" - RECESSED BASE
HZ-2195BOX-BC Black Chrome
 **Comes with washable filter
 H: 3" W: 14" Neck: 5 1/8"



1958-79 CHEVY SMALL BLOCK STOCK OIL PAN
HZ-7006-BC Black Chrome



STEEL PUSH IN BREATHER KIT
HZ-4870-KIT-BC Black Chrome
DIA.: 2-3/4" FITS.: 1-1/4" TUBES.: 5/8"

ALUMINUM SCOOPS



**SINGLE/ DUAL QUAD
BUG CATCHER STYLE SCOOP**

HZ-8007-PBK Black
HZ-8007-POL Polished

H: 5" W: 13 1/2" L: 20 1/2"



**DUAL 4 BARREL
SHOTGUN STYLE SCOOP**

** Includes Both Base Plates **

HZ-8006-POL Polished Smooth
HZ-8006-3-POL Polished Finned
HZ-8006-3-PBK Black Finned

H: 6" W: 11 1/4" L: 20 1/2"



**SINGLE 4 BARREL
HILBORN STYLE SCOOP**

** Includes Both Base Plates **

HZ-8002-PBK Black
HZ-8002-POL Polished

H: 5" W: 9 1/2" L: 13 1/2"



**SINGLE 4 BARREL
HILBORN STYLE SCOOP - FINNED**

** Includes Both Base Plates **

HZ-8002-3-PBK Black Finned
HZ-8002-3-POL Polished Finned

H: 5" W: 9 1/2" L: 13 1/2"



**SINGLE 4 BARREL
HILBORN STYLE SCOOP - 6 FINNED**

** Includes Both Base Plates **

HZ-8002-4-PBK Black Finned
HZ-8002-4-POL Polished Finned

H: 5" W: 9 1/2" L: 13 1/2"



**SINGLE OR DUAL 4 BARREL
HILBORN STYLE SCOOP - FINNED**

** Includes Both Base Plates **

HZ-8001-3-PBK Black Finned
HZ-8001-3-POL Polished Finned

H: 5" W: 9 1/2" L: 20"

12" OVAL ALUMINUM AIR CLEANER SETS

All oval air cleaner sets include top, base, 2" filter & mounting stud



12" - SMOOTH
HZ-6020-POL Polished
HZ-6020-C Chrome

H: 3" W: 8 1/4" L: 1 17/8" Neck: 5 1/8"

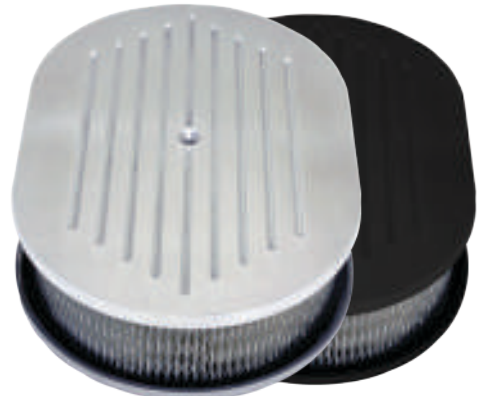

12" - BALL MILLED
HZ-6020-1-POL Polished
HZ-6020-1-C Chrome
HZ-6020-1-PBK Black

H: 3" W: 8 1/4" L: 1 17/8" Neck: 5 1/8"



12" - FULL FINNED
HZ-6020-3-POL Polished
HZ-6020-3-PBK Black
HZ-6020-3-C Chrome
HZ-6020-3-COP Copper

H: 3" W: 8 1/4" L: 1 17/8" Neck: 5 1/8"



12" - PARTIAL FINNED
HZ-6020-4-POL Polished
HZ-6020-4-PBK Black
HZ-6020-4-C Chrome
HZ-6020-4-COP Copper

H: 3" W: 8 1/4" L: 1 17/8" Neck: 5 1/8"



12" - FLAMED
HZ-6020-2-POL Polished

H: 3" W: 8 1/4" L: 1 17/8" Neck: 5 1/8"

15" OVAL ALUMINUM AIR CLEANER SETS

All oval air cleaner sets include top, base, 2" filter & mounting stud



15" - SMOOTH
HZ-6021-POL Polished
HZ-6021-C Chrome
HZ-6021-PBK Black

H: 3" W: 8 1/4" L: 15" Neck: 5 1/8"



15" - BALL MILLED
HZ-6021-1-POL Polished
HZ-6021-1-PBK Black

H: 3" W: 8 1/4" L: 15" Neck: 5 1/8"



15" - FULL FINNED
HZ-6021-3-POL Polished
HZ-6021-3-PBK Black
HZ-6021-3-C Chrome
HZ-6021-3-COP Copper

H: 3" W: 8 1/4" L: 15" Neck: 5 1/8"



15" - PARTIAL FINNED
HZ-6021-4-POL Polished
HZ-6021-4-PBK Black
HZ-6021-4-C Chrome
HZ-6021-4-COP Copper

H: 3" W: 8 1/4" L: 15" Neck: 5 1/8"



15" - FLAMED
HZ-6021-2-POL Polished

H: 3" W: 8 1/4" L: 15" Neck: 5 1/8"

19" OVAL ALUMINUM AIR CLEANER SETS



19" - SMOOTH
HZ-6029-POL Polished



Will not fit 409 dual quad carbs

H: 2 1/2" W: 9 1/8" L: 19 1/8" Neck: 5 1/8"



19" - BALL MILLED
HZ-6029-1-POL Polished

14" ROUND ALUMINUM AIR CLEANER SETS

All round air cleaner sets include top, base, 3" filter & mounting stud

AIR CLEANERS



14" - SMOOTH
HZ-6801-POL Polished
HZ-6801-C Chrome
HZ-6801-PBK Black

H: 3" W: 14" Neck: 5 1/8"

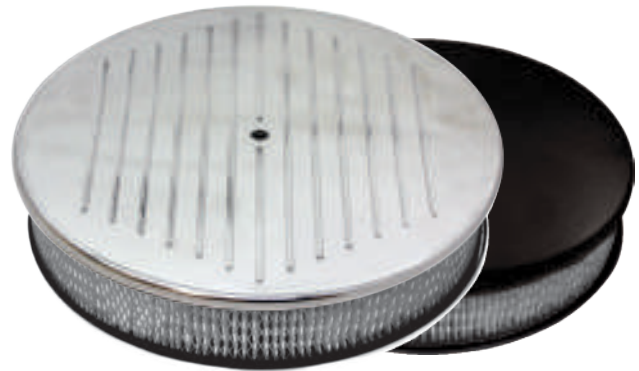

14" - BALL MILLED
HZ-6801-1-POL Polished
HZ-6801-1-C Chrome
HZ-6801-1-PBK Black

H: 3" W: 14" Neck: 5 1/8"



14" - FULL FINNED
HZ-6801-3-POL Polished
HZ-6801-3-PBK Black
HZ-6801-3-C Chrome
HZ-6801-3-COP Copper

H: 3" W: 14" Neck: 5 1/8"



14" - PARTIAL FINNED
HZ-6801-4-POL Polished
HZ-6801-4-PBK Black
HZ-6801-4-C Chrome
HZ-6801-4-COP Copper

H: 3" W: 14" Neck: 5 1/8"



14" - FLAMED
HZ-6801-2-POL Polished
HZ-6801-2-C Chrome

H: 3" W: 14" Neck: 5 1/8"

ROUND STEEL AIR CLEANER SETS

All round air cleaner sets include top, base, 3" filter & mounting stud

AIR CLEANERS



16" - DROP BASE
HZ-3148BOX-C Chrome
HZ-3148BOX-PBK Black
****HZ-3148BOX-W-C** Chrome
****HZ-3148BOX-W-PBK** Black
 **Comes with washable filter
 H: 3" W: 16" Neck: 7 1/4"



14" - RECESSED BASE
HZ-2195BOX-C Chrome
HZ-2195BOX-PBK Black
****HZ-2195BOX-W-C** Chrome
****HZ-2195BOX-W-PBK** Black
 **Comes with washable filter
 H: 3" W: 14" Neck: 5 1/8"



14" - OFF-SET BASE
HZ-5195BOX-C Chrome
HZ-5195BOX-PBK Black
****HZ-5195BOX-W-C** Chrome
****HZ-5195BOX-W-PBK** Black
 **Comes with washable filter
 H: 3" W: 14" Neck: 5 1/8"



14" - HI-LIP BASE
HZ-7195BOX-C Chrome
HZ-7195BOX-PBK Black
****HZ-7195BOX-W-C** Chrome
****HZ-7195BOX-W-PBK** Black
 **Comes with washable filter
 H: 3" W: 14" Neck: 5 1/8"



14" - FLAT BASE
HZ-2148BOX-C Chrome
HZ-2148BOX-PBK Black
****HZ-2148BOX-W-C** Chrome
****HZ-2148BOX-W-PBK** Black
 **Comes with washable filter
 H: 3" W: 14" Neck: 5 1/8"



12" - FLAT BASE
****HZ-1148BOX-W-C** Chrome
****HZ-1148BOX-W-PBK** Black
 **Comes with washable filter
 H: 3" W: 12" Neck: 5 1/8"

ALUMINUM AIR CLEANER TOPS AND BASES

All air cleaner tops include mounting stud

AIR CLEANERS



12" - SMOOTH TOP
HZ-6020T-POL Polished
HZ-6020T-C Chrome
HZ-6020T-PBK Black

W: 8 1/4" L: 11 7/8"



12" - BALL MILLED TOP
HZ-6020T-1-POL Polished
HZ-6020T-1-C Chrome
HZ-6020T-1-PBK Black

W: 8 1/4" L: 11 7/8"



12" - FLAMED TOP
HZ-6020T-2-POL Polished

W: 8 1/4" L: 11 7/8"



12" - FULL FINNED TOP
HZ-6020T-3-POL Polished
HZ-6020T-3-PBK Black
HZ-6020T-3-C Chrome
HZ-6020T-3-COP Copper

W: 8 1/4" L: 11 7/8"



12" - PARTIAL FINNED TOP
HZ-6020T-4-POL Polished
HZ-6020T-4-PBK Black
HZ-6020T-4-C Chrome
HZ-6020T-4-COP Copper

W: 8 1/4" L: 11 7/8"



HZ-6020B-POL Polished



12" - SMOOTH BOTTOM

HZ-6020B-POL Polished **HZ-6020B-PBK** Black
HZ-6020B-C Chrome **HZ-6020B-COP** Copper

W: 8 1/4" L: 11 7/8"



HZ-6020B-PBK Black

ALUMINUM AIR CLEANER TOPS AND BASES

All air cleaner tops include mounting stud



15" - SMOOTH TOP
HZ-6021T-POL Polished
HZ-6021T-C Chrome
HZ-6021T-PBK Black

W: 8 1/4" L: 15"

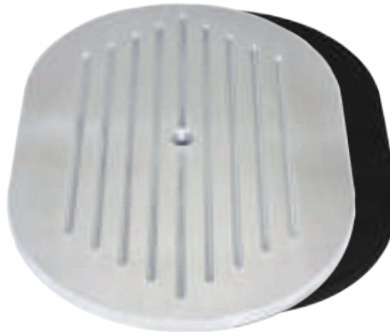

15" - BALL MILLED TOP
HZ-6021T-1-POL Polished
HZ-6021T-1-C Chrome
HZ-6021T-1-PBK Black

W: 8 1/4" L: 15"



15" - FLAMED TOP
HZ-6021T-2-POL Polished

W: 8 1/4" L: 15"



15" - FULL FINNED TOP
HZ-6021T-3-POL Polished
HZ-6021T-3-PBK Black
HZ-6021T-3-C Chrome
HZ-6021T-3-COP Copper

W: 8 1/4" L: 15"



15" - PARTIAL FINNED TOP
HZ-6021T-4-POL Polished
HZ-6021T-4-PBK Black
HZ-6021T-4-C Chrome
HZ-6021T-4-COP Copper

W: 8 1/4" L: 15"



HZ-6021B-POL Polished



HZ-6021B-PBK Black



15" - SMOOTH BOTTOM
HZ-6021B-POL Polished **HZ-6021B-PBK** Black
HZ-6021B-C Chrome **HZ-6021B-COP** Copper

W: 8 1/4" L: 15"

ALUMINUM AIR CLEANER TOPS

All air cleaner tops include mounting stud

AIR CLEANERS



14" - SMOOTH
HZ-6801T-POL Polished
HZ-6801T-C Chrome
HZ-6801T-PBK Black
L: 14" W: 14"

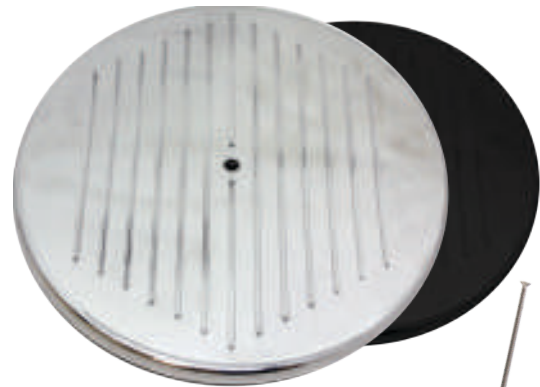

14" - BALL MILLED
HZ-6801T-1-POL Polished
HZ-6801T-1-C Chrome
HZ-6801T-1-PBK Black
L: 14" W: 14"

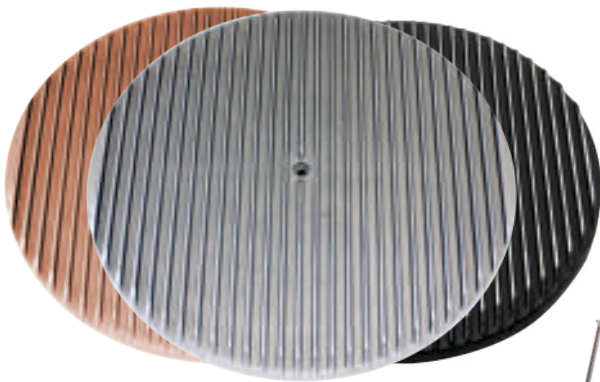

14" - FULL FINNED
HZ-6801T-3-POL Polished
HZ-6801T-3-PBK Black
HZ-6801T-3-C Chrome
HZ-6801T-3-COP Copper
L: 14" W: 14"

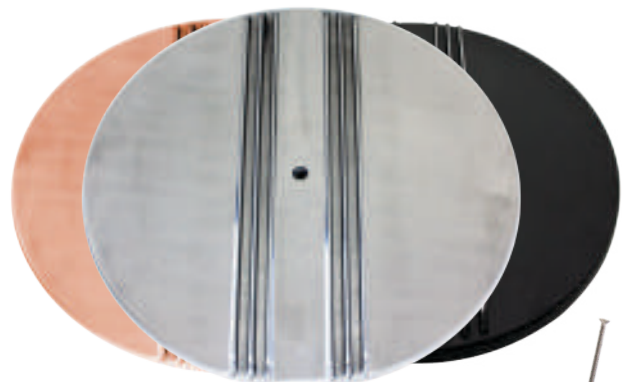

14" - PARTIAL FINNED
HZ-6801T-4-POL Polished
HZ-6801T-4-PBK Black
HZ-6801T-4-C Chrome
HZ-6801T-4-COP Copper
L: 14" W: 14"



14" - FLAMED
HZ-6801T-2-POL Polished
HZ-6801T-2-C Chrome
L: 14" W: 14"

STEEL AIR CLEANER TOPS AND BASES

All air cleaner tops include mounting stud



16"- CHEVY/FORD/MOPAR SINGLE WING NUT
HZ-3148T-C Chrome
HZ-3148T-PBK Black
 H: 3/4" W: 16"



15"- 1988-92 CHEVY/GM SINGLE WING NUT
HZ-2146T-C Chrome
HZ-2146T-PBK Black
 H: 1 7/8" W: 15 3/8"



15"- 1993-95 CHEVY/GM TRUCK DUAL WING NUT
HZ-2147T-C Chrome
HZ-2147T-PBK Black
 H: 1 7/8" W: 15 3/8"



14"- UNIVERSAL SINGLE WING NUT
HZ-2148T-C Chrome
HZ-2148T-PBK Black
 H: 3/4" W: 14"



14"- CHEVY/FORD/MOPAR SINGLE WING NUT
HZ-2195T-C Chrome
HZ-2195T-PBK Black
 H: 3/4" W: 14"



12"- CHEVY/FORD/MOPAR SINGLE WING NUT
HZ-1148T-C Chrome
HZ-1148T-PBK Black
 H: 3/4" W: 12"



16" - DROP BASE
HZ-3148B-C Chrome
HZ-3148B-PBK Black
 W: 16" Neck: 7 1/4"



14" - RECESSED BASE
HZ-2195B-C Chrome
HZ-2195B-PBK Black
 W: 14" Neck: 5 1/8"



14" - OFF SET BASE
HZ-5195B-C Chrome
HZ-5195B-PBK Black
 W: 14" Neck: 5 1/8"



14" - HI LIP BASE
HZ-7195B-C Chrome
HZ-7195B-PBK Black
 W: 14" Neck: 5 1/8"



14" - FLAT BASE
HZ-2148B-C Chrome
HZ-2148B-PBK Black
 W: 14" Neck: 5 1/8"



12" - FLAT BASE
HZ-6195B-C Chrome
HZ-6195B-PBK Black
 W: 12" Neck: 5 1/8"

STEEL AIR CLEANER BASE INFORMATION

FLAT BASE

Rises Filter 3/4"
Above Carb Flange



Will Fit All 5-1/8"
Carb Flanges

RECESSED BASE

Drops Filter 1-1/8"
Below Carb Flange



Will Not Clear
Electric Chokes

OFF SET BASE

Sets Filter 1-1/2" Off
Carb Flange



Off-Set For Distributor Or Firewall
Clearance

HI LIP BASE

Drops Filter 7/8"
Below Carb Flange



Will Clear
Electric Chokes

AIR CLEANER ACCESSORIES

REPLACEMENT AIR FILTERS

Oval Air Filters Are 2-3" Tall And Round Air Filters Are 2-4" Tall



15 x 2" - OVAL AIR FILTER

HZ-2133 Paper
HZ-3152-RED-W Washable

H: 2" W: 8 1/4" L: 15"



16 x 3" - ROUND AIR FILTER

HZ-3163 Paper
HZ-3163-RED-W Washable

H: 3" W: 16" L: 16"



12 x 2" - OVAL AIR FILTER

HZ-2123 Paper
HZ-3122-RED-W Washable

H: 2" W: 8 1/4" L: 11 7/8"



14 x 2" - ROUND AIR FILTER

HZ-2112 Paper
HZ-3142-RED-W Washable

H: 2" W: 14" L: 14"

16 x 4" - ROUND AIR FILTER

HZ-3164 Paper
HZ-3164-RED-W Washable

H: 4" W: 16" L: 16"

12 x 3" - OVAL AIR FILTER

HZ-3123-RED-W Washable



12 x 3" - ROUND AIR FILTER

HZ-1123-RED Washable

H: 3" W: 12" L: 12"

14 x 3" - ROUND AIR FILTER

HZ-2113 Paper
HZ-3143-RED-W Washable

H: 3" W: 14" L: 14"

LOUVERED



Mini Air Cleaners
Steel with paper
element &
raised base.
Fits 1BBL or 2BBL
carbs with 2 1/16"
or 2 5/8" necks.

OPEN



MINI AIR CLEANER - LOUVERED

HZ-2339-C Chrome
HZ-2339-PBK Black

MINI AIR CLEANER - OPEN

HZ-2171-C Chrome
HZ-2171-PBK Black



1/4-20"

**KNURLED AIR
CLEANER NUT**

HZ-2183-C Chrome
HZ-2183-PBK Black



1/4-20"

**AIR CLEANER
WING NUT**

HZ-2184-C Chrome
HZ-2184-PBK Black



AIR CLEANER WING NUT

1/4-20" & 5/16-18"

HZ-2180-C Chrome
HZ-2180-PBK Black



**SMOG TUBE
FITTING**

Fits 5/8" and 3/4" Hoses
HZ-2192-PBK Black

1-11/16" PORTS



**STRAIGHT AIR
CLEANER BOLT**

HZ-7196 HZ-7196-PBK
1/4-20" x 5"

HZ-2196 HZ-2196-PBK
1/4-20" x 4"

HZ-146 HZ-146-PBK
1/4-20" x 6"



**ALUMINUM AIR
CLEANER STUD**

HZ-6802
1/4-20" x 5-5/8"



**OFF SET AIR
CLEANER BOLT**

HZ-5196 HZ-5196-PBK
1/4-20" x 6"
HZ-5197
5/16-18" x 6"



**PHENOLIC CARB
SPACER - OPEN**

HZ-8301 1"
HZ-8302 2"



**PHENOLIC CARB
SPACER - PORTED**

HZ-8311 1"
HZ-8312 2"

Carb Spacers come with gasket and hardware

CHEVY BIG BLOCK STEEL VALVE COVERS



CHEVY BIG BLOCK - SMOOTH
1965-95, 396-427-454-502 BAFFLED

- HZ-9235-C** Chrome **HZ-9236-C** Chrome
- HZ-9235-PO** Orange **HZ-9236-PO** Orange
- HZ-9235-PBK** Black **HZ-9236-PBK** Black

TALL H: 35/8"

SHORT H: 25/8"



CHEVY BIG BLOCK - 454 LOGO POWDER COATED
1965-95, 396-427-454-502 BAFFLED

- HZ-9843-C** Chrome **HZ-9844-C** Chrome
- HZ-9844-PCO** Orange **HZ-9844-PCMB** Black
- HZ-9844-PCG** Grey

TALL H: 35/8"

SHORT H: 25/8"



CHEVY BIG BLOCK - OEM STYLE W/ DRIPPER RAILS
1965-72, 396-427-454 BAFFLED

- HZ-9503-1-C** Chrome
- HZ-9503-1-PO** Orange
- HZ-9503-1-PBK** Black

SHORT H: 21/4"



CHEVY BIG BLOCK - OEM STYLE
1965-72, 396-427-454 BAFFLED

- HZ-9503-T-C** Chrome **HZ-9503-C** Chrome
- HZ-9503-T-PO** Orange **HZ-9503-PO** Orange
- HZ-9503-T-PBK** Black **HZ-9503-PBK** Black

TALL H: 23/4"

SHORT H: 21/4"



****CHEVY BIG BLOCK - OEM STYLE W/NOTCH**
1965-72, 396-427-454 BAFFLED

- HZ-9504-T-C** Chrome **HZ-9504-C** Chrome
- HZ-9504-T-PO** Orange **HZ-9504-PO** Orange
- HZ-9504-T-PBK** Black **HZ-9504-PBK** Black

TALL H: 23/4"

SHORT H: 21/4"

******Recessed corner to fit Corvette & cars w/power brakes.



CHEVY BIG BLOCK - OEM STYLE W/ DRIPPER RAILS & NOTCH
1965-72, 396-427-454 BAFFLED

- HZ-9504-1-C** Chrome
- HZ-9504-1-PO** Orange
- HZ-9504-1-PBK** Black

SHORT H: 21/4"

******Recessed corner to fit Corvette & cars w/power brakes.

CHEVY BIG BLOCK ALUMINUM VALVE COVERS

VALVE COVERS



CHEVY BIG BLOCK - SMOOTH
 1965-95, 396-427-454-502 BAFFLED
HZ-8051-POL Polished
HZ-8051-PCMB Powder
 Coated Matte Black
TALL H: 3 11/16"



CHEVY BIG BLOCK - BALL MILLED
 1965-95, 396-427-454-502 BAFFLED
HZ-8051-1-POL Polished
HZ-8051-1-PCMB Powder
 Coated Matte Black
TALL H: 3 11/16"



CHEVY BIG BLOCK - FULL FINNED
 1965-95, 396-427-454-502 BAFFLED
HZ-8051-3-POL Polished
HZ-8051-3-PBK Black
HZ-8051-3-C Chrome
HZ-8051-3-COP Copper
TALL H: 3 11/16"



CHEVY BIG BLOCK - FLAMED
 1965-95, 396-427-454-502 BAFFLED
HZ-8051-2-POL Polished
TALL H: 3 11/16"



CHEVY BIG BLOCK - FLAMED 1965-95,
 396-427-454-502 BAFFLED
HZ-8044-POL Polished
SHORT H: 3 7/8"



CHEVY BIG BLOCK - SMOOTH
 1965-95, 396-427-454-502 BAFFLED
HZ-8041-POL Polished
SHORT H: 3 7/8"

**Comes without breather holes

CHEVY BIG BLOCK ALUMINUM VALVE COVERS



CHEVY BIG BLOCK - SMOOTH
OEM STYLE 1965-95, 396-427-454-502 BAFFLED
HZ-8042-POL Polished
SHORT H: 27/8"



CHEVY BIG BLOCK - BALL MILLED
1965-95, 396-427-454-502 BAFFLED
HZ-8043-POL Polished
SHORT H: 27/8"

CHEVY SMALL BLOCK STEEL VALVE COVERS



CHEVY SMALL BLOCK
1958-86, 283-305-327-350-400 BAFFLED
HZ-9215-C Chrome **HZ-9216-C** Chrome
HZ-9215-PO Orange **HZ-9216-PO** Orange
HZ-9215-PBK Black **HZ-9216-PBK** Black
TALL H: 35/8" **SHORT H: 25/8"**



CHEVY SMALL BLOCK - OEM STYLE W/ TWIST IN CAP
1958-86, 283-305-327-350-400 BAFFLED
HZ-9518-C Chrome **HZ-9518-PO** Orange
HZ-9518-PBK Black **HZ-9518-R** Raw
SHORT H: 25/8"



CHEVY SMALL BLOCK - FLAT TOP
1958-86, 283-305-327-350-400 BAFFLED
HZ-9519-C Chrome **HZ-9519-PO** Orange
HZ-9519-PBK Black **HZ-9519-R** Raw
TALL H: 35/8"



CHEVY SMALL BLOCK - FLAT TOP
1958-86, 283-305-327-350-400 BAFFLED
HZ-9517-PBK Black
SHORT H: 25/8"



CHEVY SMALL BLOCK - PIN STRIPE
1958-86, 283-305-327-350-400 BAFFLED

HZ-9215-V Chrome **HZ-9216-V** Chrome
TALL H: 35/8" SHORT H: 25/8"



CHEVY SMALL BLOCK - FLAMED
1958-86, 283-305-327-350-400 BAFFLED

HZ-9215-F Chrome **HZ-9216-F** Chrome
TALL H: 35/8" SHORT H: 25/8"



CHEVY SMALL BLOCK - 327 LOGO
1958-86, 327 BAFFLED

HZ-9853-C Chrome **HZ-9854-C** Chrome
HZ-9853-PBK Black **HZ-9854-PBK** Black
TALL H: 35/8" SHORT H: 25/8"

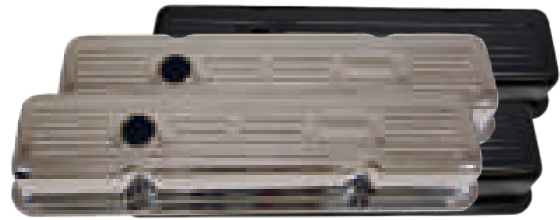

CHEVY SMALL BLOCK - 350 LOGO
1958-86, 350 BAFFLED

HZ-9841-C Chrome **HZ-9842-C** Chrome
HZ-9841-PBK Black **HZ-9842-PBK** Black
TALL H: 35/8" SHORT H: 25/8"

CHEVY SMALL BLOCK CENTER BOLT STEEL VALVE COVERS



CHEVY SMALL BLOCK - OEM STYLE
1987-00, 5.0L & 5.7L V8 BAFFLED

HZ-9705-C Chrome **HZ-9702-C** Chrome
HZ-9705-PBK Black **HZ-9702-PBK** Black
TALL H: 311/16" SHORT H: 23/8"

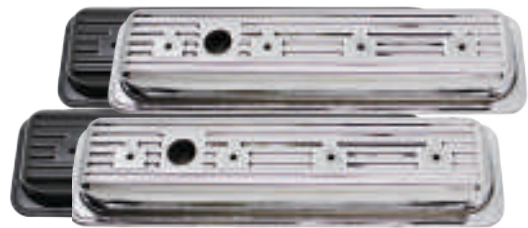

CHEVY SMALL BLOCK - OEM STYLE ONE HOLE
1987-00, 5.0L & 5.7L V8 BAFFLED

HZ-9703-C Chrome
HZ-9703-PBK Black
SHORT H: 23/8"



CHEVY SMALL BLOCK - OEM STYLE TWO HOLE
1987-00, 5.0L & 5.7L V8 BAFFLED
HZ-9704-C Chrome
HZ-9704-PBK Black
SHORT H: 23/8"

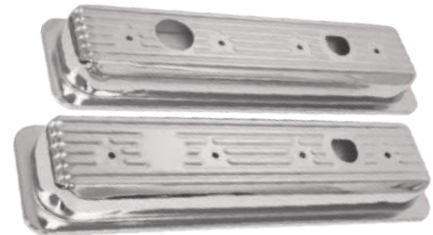

CHEVY SMALL BLOCK - OEM STYLE CAPS
1987-00, 5.0L & 5.7L V8 BAFFLED
HZ-9460-C Chrome
HZ-9460-PBK Black
SHORT H: 23/8"
**Caps fit over existing OEM covers.

CHEVY SMALL BLOCK ALUMINUM CENTER BOLT VALVE COVERS



CHEVY SMALL BLOCK - SMOOTH POLISHED
1987-97, 5.0L & 5.7L V8 UNBAFFLED
HZ-8031-POL Polished
TALL H: 311/16"



CHEVY SMALL BLOCK - SMOOTH POLISHED
1987-97, 283-305-327-350-400 BAFFLED
HZ-8032-POL Polished **HZ-6991-POL** Polished
TALL H: 311/16" **SHORT H: 29/16"**

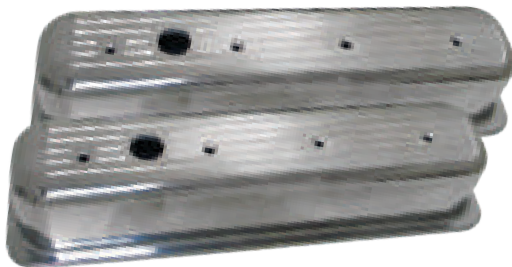

CHEVY SMALL BLOCK - BALL MILLED POLISHED
1987-97, 283-305-327-350-400 BAFFLED
HZ-8033-POL Polished **HZ-6991-1-POL** Polished
TALL H: 311/16" **SHORT H: 2-9/16"**



CHEVY SMALL BLOCK - RETRO FINNED
1987-97, 283-305-327-350-400 BAFFLED
HZ-8033-3-POL Polished **HZ-6991-3-POL** Polished
HZ-8033-3-PBK Black **HZ-6991-3-PBK** Black
HZ-8033-3-C Chrome **HZ-6991-3-C** Chrome
HZ-8033-3-COP Copper **HZ-6991-3-COP** Copper
TALL H: 3-11/16" **SHORT H: 2-3/8"**

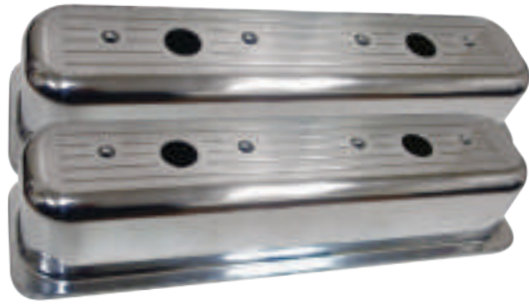

**CHEVY SMALL BLOCK - CENTER BOLT
CIRCLE TRACK 1987-97, 5.0L & 5.7L V8**

HZ-8233-POL Polished

TALL H: 3-11/16"

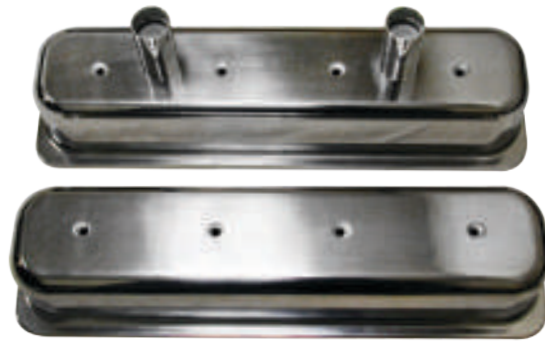

**CHEVY SMALL BLOCK - CENTER BOLT
CIRCLE TRACK 1987-97, 5.0L & 5.7L V8** BAFFLED

HZ-8039-POL Polished

TALL H: 3-11/16"

Welded Driver Side
Breather Tubes with
1-1/2" O.D

CHEVY SMALL BLOCK STEEL CIRCLE TRACK BOLT VALVE COVERS



**CHEVY SMALL BLOCK - CIRCLE TRACK
1958-86, 283-305-327-350-400** BAFFLED

HZ-7215-PBK Black

HZ-7216-R Raw

HZ-7215-R Raw

HZ-7216-Z Zinc

HZ-7215-Z Zinc

SHORT H: 2-5/8"

TALL H: 3-3/8"



Welded Driver Side
Breather Tubes with
1-1/2" O.D



Welded Driver Side
Breather Tubes with
1-3/8" O.D

**CHEVY SMALL BLOCK - CIRCLE TRACK
1958-86, 283-305-327-350-400** BAFFLED

HZ-6140-C Chrome

TALL H: 3-11/16"

CHEVY SMALL BLOCK ALUMINUM VALVE COVERS



**CHEVY SMALL BLOCK - SMOOTH
1958-86, 283-305-327-350-400** BAFFLED

HZ-6033-POL Polished

HZ-6033-C Chrome

TALL H: 3-11/16"



**CHEVY SMALL BLOCK - BALL MILLED
1958-86, 283-305-327-350-400** BAFFLED

HZ-6033-1-POL Polished

HZ-6033-1-C Chrome

TALL H: 3-11/16"

CHEVY SMALL BLOCK ALUMINUM VALVE COVERS



CHEVY SMALL BLOCK - FLAMED
1958-86, 283-305-327-350-400 BAFFLED
HZ-6033-2-POL Polished
HZ-6033-2-C Chrome
TALL H: 3-11/16"



CHEVY SMALL BLOCK - SMOOTH FLAT
1958-86, 283-305-327-350-400 BAFFLED
HZ-6720-C Chrome **HZ-6031-POL** Polished
HZ-6720-POL Polished **SHORT H: 2-9/16"**
TALL H: 3-11/16"



CHEVY SMALL BLOCK - BALL MILLED
1958-86, 283-305-327-350-400 BAFFLED
HZ-6720-1-C Chrome **HZ-6031-1-POL** Polished
HZ-6720-1-POL Polished **SHORT H: 2-9/16"**
TALL H: 3-11/16"



CHEVY SMALL BLOCK - FLAMED
1958-86, 283-305-327-350-400 BAFFLED
HZ-6720-2-C Chrome **HZ-6031-2-C** Chrome
HZ-6720-2-POL Polished **HZ-6031-2-POL** Polished
TALL H: 3-11/16" **SHORT H: 2-9/16"**



CHEVY SMALL BLOCK - RETRO FINNED W/HOLE
1958-86, 283-305-327-350-400 BAFFLED
HZ-6720-3-POL Polished **HZ-6031-3-POL** Polished
HZ-6720-3-PBK Black **HZ-6031-3-PBK** Black
HZ-6720-3-C Chrome **HZ-6031-3-C** Chrome
HZ-6720-3-COP Copper **HZ-6031-3-COP** Copper
TALL H: 3-11/16" **SHORT H: 2-9/16"**



CHEVY SMALL BLOCK - RETRO FINNED W/HOLE
1958-86, 283-305-327-350-400 BAFFLED
HZ-6720-3-H-POL Polished
TALL H: 3-11/16"
HZ-6031-3-H-POL Polished
SHORT H: 2-9/16"

CHEVY SMALL BLOCK ALUMINUM VALVE COVERS

Light weight aluminum has a 45% weight reduction compared to steel.
1958-86 Chevy 283-305-327-350-400. Baffled and 3-3/8" tall



CHEVY SMALL BLOCK - STAMPED SMOOTH
1958-86, 283-305-327-350-400 BAFFLED
HZ-8115-PBK Black **HZ-8115-R** Raw
HZ-8115-PBL Blue **HZ-8115-RED** Red
HZ-8115-SIL Silver

TALL H: 3-3/8"



Twist-in
Cap

CHEVY SMALL BLOCK - STAMPED SMOOTH
1958-86, 283-305-327-350-400 BAFFLED
HZ-8519-PBK Black **HZ-8519-R** Raw
HZ-8519-PBL Blue **HZ-8519-RED** Red
HZ-8519-SIL Silver

TALL H: 3-3/8"



1-1/2"
O.D. Tubes



CHEVY SMALL BLOCK - STAMPED SMOOTH
1958-86, 283-305-327-350-400 BAFFLED
HZ-8215-PBK Black **HZ-8215-R** Raw
HZ-8215-PBL Blue **HZ-8215-RED** Red
HZ-8215-SIL Silver

TALL H: 3-3/8"

CHEVY V6 STEEL VALVE COVERS



CHEVY V6 - CENTER BOLT BALL MILLED
1985-93, 4.3L V6 BAFFLED
HZ-7458-C Chrome
HZ-7458-PBK Black
SHORT H: 2-1/2"



CHEVY V6 - SMOOTH
1980-84, 229 3.8L V6
HZ-9039-C Chrome

TALL H: 3"

Will Fit Brodix Heads

CHEVY STRAIGHT INLINE 6 STEEL VALVE COVERS



CHEVY STRAIGHT 6 - SMOOTH
1962-74, 194-230-250-L6 BAFFLED

- HZ-9233-C** Chrome **HZ-9341-C** Chrome
HZ-9233-PBK Black **HZ-9341-PBK** Black
 Valve Cover Only Side Plate Only
(Does not fit 292)

- HZ-9233-KIT-C** Chrome
HZ-9233-KIT-PBK Black
 Full Kit

TALL H: 3-1/2"

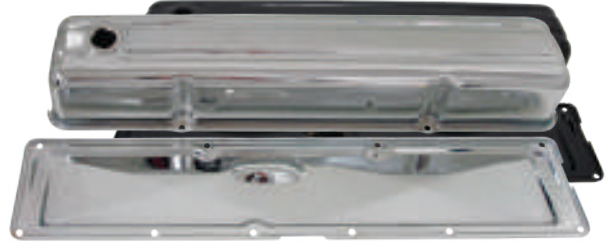

CHEVY STRAIGHT 6 - SMOOTH
1952-62, 236-L6 UNBAFFLED

- HZ-9107-C** Chrome **HZ-9108-C** Chrome
HZ-9107-PBK Black **HZ-9108-PBK** Black
 Valve Cover Only Side Plate Only

- HZ-9107-KIT-C** Chrome
HZ-9107-KIT-PBK Black
 Full Kit

TALL H: 3-7/8"



CHEVY STRAIGHT 6 - SMOOTH
1942-53, 216-L6 UNBAFFLED

- HZ-9110-C** Chrome
HZ-9110-PBK Black

TALL H: 4-1/4"



FOR BIG BLOCK STEEL VALVE COVERS



BIG BLOCK FORD VALVE COVERS - FE
1957-76 320-352-406-427-428 BAFFLED

- HZ-9296-C** Chrome
HZ-9296-PBK Black

TALL H: 3-7/8"



BIG BLOCK FORD VALVE COVERS -
1968-97 429-460 BAFFLED

- HZ-9297-C** Chrome
HZ-9297-PBK Black

TALL H: 3-1/2"

FORD SMALL BLOCK STEEL VALVE COVERS

VALVE COVERS



FORD Y-BLOCK VALVE COVERS - OEM STYLE

1955-64, 272-292-312 BAFFLED
HZ-7541-C Chrome
HZ-7541-PBK Black

TALL H: 3-1/2"



FORD SMALL BLOCK VALVE COVERS - SMOOTH

1962-85, 260-289-302-351W 5.0L BAFFLED
HZ-9237-C Chrome **HZ-9237-PBL** Blue
HZ-9237-PBK Black **HZ-9237-R** Raw

TALL H: 3-1/2"



FORD SMALL BLOCK VALVE COVERS - FLAMED

1962-85, 260-289-302-351W 5.0L BAFFLED
HZ-9237-F Chrome

TALL H: 3-1/2"



FORD VALVE COVERS - SMOOTH BAFFLED

1969-82, 351C-351M-400M-BOSS 302

HZ-9295-C Chrome
HZ-9295-PBK Black

TALL H: 3-5/8"



FORD VALVE COVERS - SMOOTH

1986-95, Mustang 5.0L V8 UNBAFFLED

HZ-9239-C Chrome
HZ-9239-PBK Black

TALL H: 3-1/2"



FORD VALVE COVERS - CIRCLE TRACK

1962-85, 260-289-302-351W BAFFLED

HZ-7225-Z Zinc
HZ-7225-PBL Blue

TALL H: 3-1/2"



Welded Breather Tubes

FORD SMALL BLOCK ALUMINUM VALVE COVERS



FORD SMALL BLOCK VALVE COVERS - SMOOTH
1962-85, 289-302-351W 5.0L BAFFLED
HZ-6728-C Chrome **HZ-6728-H** w/o Holes
HZ-6728-POL Polished **HZ-6728-PCMB** PC Black

TALL H: 3-13/16"



FORD SMALL BLOCK VALVE COVERS - BALL MILLED
1962-85, 289-302-351W 5.0L BAFFLED
HZ-6728-1-C Chrome
HZ-6728-1-POL Polished

TALL H: 3-13/16"



FORD SMALL BLOCK VALVE COVERS - FINNED
1962-85, 289-302-351W 5.0L BAFFLED
HZ-6728-3-POL Polished **HZ-6728-3-PBK** Black
HZ-6728-3-H w/o Holes **HZ-6728-3-C** Chrome
HZ-6728-3-COP Copper

TALL H: 3-13/16"



FORD SMALL BLOCK VALVE COVERS - FLAMED
1962-85, 289-302-351W 5.0L BAFFLED
HZ-6728-2-C Chrome

TALL H: 3-13/16"

FORD L6/V6 STEEL VALVE COVERS



FORD L6 VALVE COVERS - SMOOTH
1960-83, 144-170-200-250 L6 BAFFLED
HZ-9338-C Chrome
HZ-9338-PBK Black

TALL H: 4-1/4"



FORD L6 VALVE COVERS - SMOOTH
1965-89, 240-300 L6 BAFFLED
HZ-9357-C Chrome
HZ-9357-PBK Black

TALL H: 3-1/4"

FORD L6/V6 STEEL VALVE COVERS



FORD L6 VALVE COVERS - SMOOTH
 1982-04, 232 3.8L V6 BAFFLED
HZ-9432-C Chrome
HZ-9432-PBK Black
TALL H: 2-3/4"

BUICK STEEL VALVE COVERS



BUICK VALVE COVERS - SMOOTH
 1968-81, 350 V8 UNBAFFLED
HZ-7554-C Chrome
HZ-7554-PBK Black
TALL H: 2-13/16"

BUICK V6 VALVE COVERS - SMOOTH
 1975-88, 231 3.8L V6 UNBAFFLED
HZ-4964-C Chrome
TALL H: 3"
 Will not fit some models with air conditioning

OLDSMOBILE STEEL VALVE COVERS



OLDSMOBILE VALVE COVERS - SMOOTH
 1964-88, 330-350-400-425-455 BAFFLED
HZ-9391-1-C Chrome
HZ-9391-1-PBK Black
TALL H: 3-3/8"

OLDSMOBILE VALVE COVERS - SMOOTH
 1964-88, 330-350-400-425-455 BAFFLED
HZ-9391-C Chrome
HZ-9391-PBK Black
SHORT H: 2-11/16"

PONTIAC VALVE COVERS



PONTIAC VALVE COVERS - SMOOTH BAFFLED
1959-79, 301-326-350-389-400-421-428-455

HZ-9300-C Chrome
HZ-9300-PBK Black

TALL H: 3-1/2"



PONTIAC VALVE COVERS - SMOOTH UNBAFFLED
1959-79, 301-326-350-389-400-421-428-455

HZ-9461-C Chrome
HZ-9461-PBK Black

SHORT H: 2-5/8"



PONTIAC ALUMINUM VALVE COVERS - FINNED
326-455 BAFFLED

HZ-6032-3-POL Polished **HZ-6032-3-PBK** Black
HZ-6032-3-C Chrome **HZ-6032-3-COP** Copper

TALL H: 4"

AMC/JEEP STEEL VALVE COVERS



AMC/JEEP VALVE COVERS - SMOOTH
1964-88, 199-232-258-L6 BAFFLED

HZ-9339-C Chrome Will not fit models with plastic valve cover.
HZ-9339-PBK Black

TALL H: 3-1/2"



AMC/JEEP VALVE COVERS - SMOOTH
1968-79, 304-360-390-401 V8 UNBAFFLED

HZ-9174-C Chrome
HZ-9174-PBK Black

TALL H: 3-1/8"

CADILLAC STEEL VALVE COVERS



CADILLAC VALVE COVERS - SMOOTH
 1968-79, 368-425-472-500/
 1977-79, 425/1980-84, 368 UNBAFFLED
HZ-9521-C Chrome
HZ-9521-PBK Black
TALL H: 2-13/16"

MOPAR STEEL VALVE COVERS



CHRYSLER VALVE COVERS - SMOOTH
 1967-89, 318-340-360 BAFFLED
HZ-9298-C Chrome
HZ-9298-PBK Black
TALL H: 3-1/4"

CHRYSLER VALVE COVERS - SMOOTH
 1958-88, 383-426-440 BAFFLED
HZ-9299-C Chrome
HZ-9299-PBK Black
TALL H: 3-3/4"



CHRYSLER SLANT 6 VALVE COVERS - SMOOTH
 1958-80, 170-198-225 UNBAFFLED
HZ-9520-C Chrome
HZ-9520-PBK Black
TALL H: 4-1/2"

VALVE COVER GASKETS

VALVE COVERS GASKETS

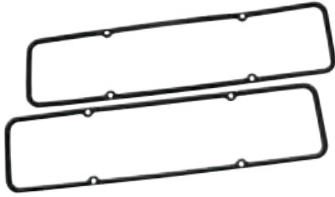

SMALL BLOCK CHEVY
1955-86
283-305-327-350-400
HZ-7484

RUBBER STEEL CORE
THICKNESS: 0.71"



BIG BLOCK CHEVY
1965-85
396-402-427-454
HZ-7485

RUBBER STEEL CORE

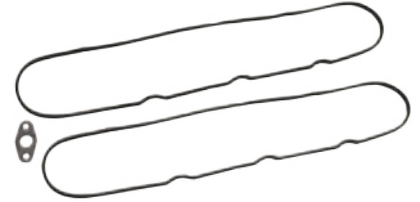

1999-2016 CHEVY LS
4.8L-5.3L-5.7L-6.2L
HZ-7998

RUBBER
(Include secondary air injection
check valve pipe gasket)



CHEVY/GM CENTER BOLT
1987-UP
HZ-7488

RUBBER STEEL CORE
THICKNESS: 0.79"

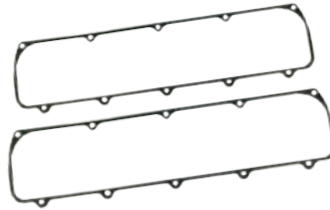

OLDSMOBILE
1964-88
330-455
HZ-7490

RUBBER STEEL CORE
THICKNESS: 0.71"



SMALL BLOCK FORD
1962-85
260-289-302-351W
HZ-7486

RUBBER STEEL CORE
THICKNESS: 0.59"



SMALL BLOCK FORD
1969-82
351C-400M
HZ-7491

RUBBER STEEL CORE



BIG BLOCK FORD
1957-76
360-390
HZ-7492

RUBBER STEEL CORE



BIG BLOCK FORD
1968-97
429-460
HZ-7493

RUBBER STEEL CORE



CHRYSLER
1967-89
318-340-380 V8
HZ-7494

RUBBER STEEL CORE

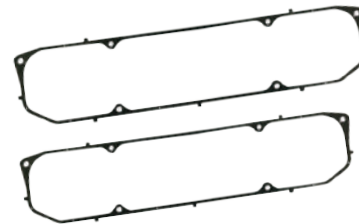

CHRYSLER
1958-88
383-426-440 V8
HZ-7495

RUBBER STEEL CORE

STEEL BREATHERS



STEEL PUSH IN BREATHER
HZ-4870-C Chrome
HZ-4870-PBK Black
HZ-4870-PO Orange

DIA.: 2-3/4" **FITS.:** 1-1/4" **TUBES.:** 5/8"



STEEL PUSH IN BREATHER
HZ-9241-C Chrome
HZ-9241-PBK Black

DIA.: 2-3/4" **FITS.:** 1-1/4" **TUBES.:** 5/8"



OIL FILLER CAP
HZ-4802-C Chrome
DIA.: 2-1/2" **FITS.:** 1-1/4"



STEEL PUSH IN BREATHER KIT
HZ-4870-KIT-C Chrome
HZ-4870-KIT-PBK Black
HZ-4870-KIT-PO Orange

DIA.: 2-3/4" **FITS.:** 1-1/4" **TUBES.:** 5/8"



STEEL PUSH IN BREATHER KIT
HZ-9241-KIT-C Chrome
HZ-9241-KIT-PBK Black

DIA.: 2-3/4" **FITS.:** 1-1/4" **TUBES.:** 5/8"



MOPAR PUSH IN BREATHER CAP
HZ-9169-C Chrome

ALUMINUM BREATHERS



ALUMINUM PUSH IN BREATHER SMOOTH
HZ-6101-C Chrome
HZ-6101-PBK Black
HZ-6101-POL Polished

DIA.: 2-3/8" **FITS.:** 1-1/4" **TUBES.:** 5/8"



ALUMINUM PUSH IN BREATHER BALL MILLED
HZ-6101-1-C Chrome
HZ-6101-1-PBK Black
HZ-6101-1-POL Polished

DIA.: 2-3/8" **FITS.:** 1-1/4" **TUBES.:** 5/8"



ALUMINUM PUSH IN BREATHER FINNED
HZ-6119-PBK Black
HZ-6119-POL Polished
HZ-6119-C Chrome
HZ-6119-COP Copper

DIA.: 2-3/8" **FITS.:** 1-1/4" **TUBES.:** 5/8"



ALUMINUM PUSH IN BREATHER SMOOTH - PCV
HZ-6100-C Chrome
HZ-6100-PBK Black
HZ-6100-POL Polished

DIA.: 2-3/8" **FITS.:** 1-1/4" **TUBES.:** 5/8"



ALUMINUM PUSH IN BREATHER BALL MILLED - PCV
HZ-6100-1-C Chrome
HZ-6100-1-PBK Black
HZ-6100-1-POL Polished

DIA.: 2-3/8" **FITS.:** 1-1/4" **TUBES.:** 5/8"



ALUMINUM PUSH IN BREATHER FINNED - PCV
HZ-6120-PBK Black
HZ-6120-POL Polished
HZ-6120-C Chrome
HZ-6120-COP Copper

DIA.: 2-3/8" **FITS.:** 1-1/4" **TUBES.:** 5/8"



ALUMINUM PUSH IN PCV VALVE
HZ-6116-PBK Black
HZ-6116-POL Polished
NECK: 3/4" **FITS.:** 1-1/4"



ALUMINUM PUSH IN BREATHER FLAMED
HZ-6101-2-C Chrome
HZ-6101-2-POL Polished
DIA.: 2-3/8" **FITS.:** 1-1/4" **TUBES.:** 5/8"



ALUMINUM PUSH IN BREATHER FLAMED - PCV
HZ-6100-2-C Chrome
HZ-6100-2-POL Polished
DIA.: 2-3/8" **FITS.:** 1-1/4" **TUBES.:** 5/8"

WASHABLE CLAMP ON BREATHERS



FITS 1-1/2" TUBES W/SHIELD
HZ-6130-C Chrome



FITS 1-3/8" TUBES W/SHIELD
HZ-6131-C Chrome



FITS 1-1/2" TUBES
HZ-6132-C Chrome



FITS 1-3/8" TUBES
HZ-6133-C Chrome

RUBBER GROMMETS

1/8" wide groove in grommet for aluminum v/c'S
1/4" wide groove in grommet for steel v/c'S



BREATHER - STEEL
HZ-4877

O.D.: 1-1/4" I.D.: 1"



PCV - STEEL
HZ-4998

O.D.: 1-1/4" I.D.: 3/4"



PCV OIL BAFFLE - STEEL
HZ-9359

O.D.: 1-1/4" I.D.: 3/4"



BREATHER - ALUMINUM
HZ-4879

O.D.: 1-1/4" I.D.: 1"



PCV - ALUMINUM
HZ-4880

O.D.: 1-1/4" I.D.: 3/4"



PCV OIL BAFFLE - ALUMINUM
HZ-9361

O.D.: 1-1/4" I.D.: 3/4"



OIL BAFFLE - STEEL
HZ-9538

O.D.: 1-1/4" I.D.: 1"



OIL BAFFLE - ALUMINUM
HZ-9360

O.D.: 1-1/4" I.D.: 1"



BREATHER/PCV - STEEL
HZ-4878

O.D.: 1-1/4" I.D.: 1"

MUST BE CUT BEFORE USE

CHROME OIL CAPS & PLUGS



UNIVERSAL VALVE OVER OIL CAP TWIST IN - STEEL

HZ-4804-C Chrome
HZ-4804-PBK Black

DIA.: 1-1/4"



UNIVERSAL VALVE OVER OIL CAP PUSH IN - STEEL

HZ-9170-C Chrome
HZ-9170-PBK Black

DIA.: 1-1/4"



1987-UP CHEVY VALVE COVER OIL CAP SCREW IN - PLASTIC

HZ-9696-C Chrome



1987-UP CHEVY VALVE COVER OIL CAP SCREW IN - BILLET ALUMINUM

HZ-9696B-C Chrome



1987-UP CHEVY VALVE COVER OIL CAP SCREW IN - BILLET ALUMINUM

HZ-9696B-POL Polished



UNIVERSAL OIL CAP PUSH IN W/ OIL LOGO

HZ-9787-C Chrome
HZ-9787-PBK Black

VALVE COVER BOLTS & HOLD DOWNS

VALVE COVERS BOLTS

***1/4"-20 Threads:** 1955-86 Chevy V8, 1958-79 Oldsmobile V8, 1964-90 Ford 260-289-302-351W V8, 1959-90 Chrysler V8 (not Hemi).
****5/16"-18 Threads:** 1958-UP Ford SB 332-352-390-406-427 & Ford BB 429-460 V8, 1955-77 Pontiac V8.



***HZ-7283-C**
***HZ-7283-PBK**

1-3/8" Tall Valve Covers
 Hex Mini Bolts
 (1/4"-20 X 1-3/8" Studs)

Universal 1 Piece
 or Sets

****HZ-7284-C**
****HZ-7284-PBK**

1-3/8" Tall Valve Covers
 Hex Mini Bolts
 (5/16"-18 X 1-1/2" Studs)
 Universal 1 Piece
 or Sets



***HZ-7281-C**
***HZ-7281-PBK**

Steel Acorn Nut Bolt 1" Tall
 1/4-20 X 7/8" 1 3/8" Studs
 Universal 1 Piece
 or 8 piece set



HZ-4993-C Chrome
HZ-4993-PBK Black

Valve Cover
 Hold Down Tabs/
 Spreader Bars
 SBC 1 Piece



HZ-9640-C Chrome
HZ-9640-PBK Black

Valve Cover
 Hold Down Tabs/
 Spreader Bars
 BBC 14 Pieces



HZ-9641-C
HZ-9641-PBK

Valve Cover
 Hold Down Tabs/
 Spreader Bars
 Pontiac Big Block
 1 Piece



Stainless Steel

HZ-8096
 Center Bolt Tall
 Aluminum Valve
 Cover Bolt (1/4"-20 x 5")
 Chevy/GMC 4.3L,
 5.0L & 5.7L
 8 Pieces



Chrome
HZ-150

3/4" Tall Valve Cover
 Hex Head bolts
 (1/4"-20 Thread)
 Universal 1 Piece
 or Sets



Chrome

***HZ-4137-C**
 3-1/2" Tall 2 Piece
 Valve Cover Wing Nuts
 (1/4"-20 X 1" Studs)
 Universal 1 Piece
 or Sets



****HZ-4138-C**
 3-1/2" Tall 2 Piece
 Valve Cover Wing Nuts
 (5/16"-18 X 1" Studs)
 Universal 1 Piece
 or Sets



HZ-9067-C Chrome
HZ-9067-PBK Black
 Valve Cover
 Mini Hold Down Tabs
 (1-1/2" wide, 1/4" Bolt Hole)
 SBC 1 Piece



Chrome

***HZ-9120-C**
 4" Tall T-Bar 1 Piece
 Valve Cover Wing Nuts
 (1/4"-20 X 1-3/8" Studs)

***HZ-4936-C**
 5" Tall T-Bar 1 Piece
 Valve Cover Wing Nuts
 (1/4"-20 X 1-3/8" Studs)

****HZ-9672-C**
 5" Tall T-Bar
 Valve Cover Wing Nuts
 (5/16"-18 X 1-1/2" Studs)
 Universal 1 Piece or Sets



HZ-9670-C
 4" Tall T-Bar
 Valve Cover Wing Nuts
 (1/4"-20 X 1-3/8" Studs)
 Universal 1 Piece or Sets



***HZ-9812-C** Chrome
***HZ-9812-PBK** Black
 Center Bolt Steel Valve Cover Bolt
 Hex Head bolts
 (1/4"-20 x 3/12" Studs)
 Chevy/GMC 4.3L,
 5.0L & 5.7L
 HZ-9702, HZ-9703, HZ-9704
 8 Pieces



HZ-9813-C Chrome
HZ-9813-PBK Black
 Steel Center Valve Cover Bolt
 HZ-9705
 8 Pieces



HZ-9642-C Chrome
HZ-9642-PBK Black
 Valve Cover Hold Down Tabs/
 Spreader Bars
 Ford 260-351W kit of 6

ALUMINUM WIRE LOOM KIT

These wire looms can handle up to a 9.5 mm wire and come complete with four L-Brackets that are adjustable and all the necessary hardware for installation. **Note:** Will not fit center bolt valve covers (see HZ-6089 below).

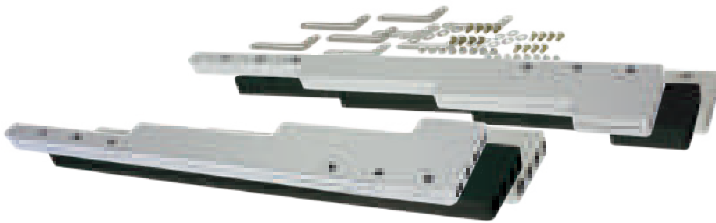

ALUMINUM WIRE LOOM KIT - SMOOTH
HZ-6061-C Chrome / **HZ-6061-PBK** Black
HZ-6061-POL Polished



ALUMINUM WIRE LOOM KIT - BALL MILLED
HZ-6061-1-C Chrome / **HZ-6061-1-PBK** Black
HZ-6061-1-POL Polished



ALUMINUM WIRE LOOM KIT - FINNED
HZ-6061-3-POL Polished
HZ-6061-3-PBK Black
HZ-6061-3-C Chrome
HZ-6061-3-COP Copper



ALUMINUM WIRE LOOM KIT - FLAMED
HZ-6061-2-C Chrome
HZ-6061-2-POL Polished

WIRE LOOM BRACKET/CLAMP KIT



ALUMINUM WIRE LOOM BRACKET KIT
HZ-6089

Brackets that mount wire looms to center bolt valve covers. They do not work with the early model valve covers (mount bolts on the side of the heads).



ALUMINUM WIRE CLAMP KIT
HZ-1702 9.5MM / **HZ-1703** 7.7MM
HZ-1704 6.0MM / **HZ-1705** 4.5MM

CHEVY BIG BLOCK



HZ-3026-C

CHEVY SMALL BLOCK



HZ-3023-PBK

Part #	Engine	Type	Finish
HZ-3027-C	1965-90 BBC 396-402-427-454	Short Smooth	Chrome
HZ-3027-PBK		Short Smooth	Black EDP
HZ-3026-C		Tall Smooth	Chrome
HZ-3026-PBK		Tall Smooth	Black EDP

- Kit Includes:**
- 1 Pair Steel Baffled Valve Covers - HZ-9236/9235
 - 1 Steel Timing Chain Cover - HZ-4935
 - 1 Steel Timing Tab - HZ-4961
 - 1 Steel Engine Dipstick w/ Tube - HZ-4958
 - 1 Steel Push-In Breather Cap - HZ-4870
 - 1 Rubber Push-In Breather Grommet - HZ-4878
 - 1 Rubber Push-In PCV Grommet - HZ-4998

Part #	Engine	Type	Finish
HZ-3023-C	1958-86 SBC 283-305-327-350	Short Smooth	Chrome
HZ-3023F		Short Flamed	Chrome
HZ-3023-PBK		Short Smooth	Black EDP
HZ-3024-C		Tall Smooth	Chrome
HZ-3024F		Tall Flamed	Chrome
HZ-3024-PBK		Tall Smooth	Black EDP

- Kit Includes:**
- 1 Pair Steel Baffled Valve Covers - HZ-9216/9215
 - 1 Steel Timing Chain Cover - HZ-4934
 - 1 Steel Timing Tab - HZ-4960
 - 1 Steel Engine Dipstick w/ Tube - HZ-4957
 - 1 Steel Push-In Style Breather Cap - HZ-4870
 - 1 Rubber Push-In Breather Grommet - HZ-4878
 - 1 Rubber Push-In PCV Grommet - HZ-4998

CHEVY SMALL BLOCK



Part #	Engine	Type	Finish
HZ-3022-PBK	1958-86 SBC 283-305-327-350	Tall Smooth	Black EDP

- Kit Includes:**
- 1 1958-79 Stock OEM Style Oil Pan - HZ-7005-PBK
 - 1 Pair 1958-86 Tall Steel Valve Covers - HZ-9215-PBK
 - 1 14" Air Cleaner Set w/ Recessed Base - HZ-2195BOX-PBK
 - 1 Steel Breather Set - HZ-4870-PBK-SET
 - 1 Air Cleaner Wing Nut w/ 5/16" threads - HZ-2180

CHEVY TRUCK



HZ-3125

Part #	Engine	Type	Finish
HZ-3125-C	1988-92 5.0L & 5.7L	Ball Milled	Chrome
HZ-3126-C	1993-94 5.0L & 5.7L	Ball Milled	Chrome

- Kit Includes:**
- 1 Pair Chrome Steel Valve Cover Caps - HZ-9460
 - 8 Chrome Steel Center Valve Cover Bolts - HZ-9812
 - 1 Chrome Steel Air Cleaner Top - HZ-2146T/2147T
 - 1 Chrome Plastic Brake Cylinder Top Cover - HZ-9635
 - 1 Chrome Plastic Power Steering Cap Cover - HZ-9257
 - 1 Chrome Plastic Screw-In Style Oil Cap - HZ-9696

FORD SMALL BLOCK

Part #	Engine	Type	Finish
HZ-3025-C	1962-85 SBF 260-289-302-351W-5.0L	Smooth	Chrome
HZ-3025F		Flamed	Chrome
HZ-3025-PBK		Smooth	Black

Kit Includes:

- 1 Pair Steel Baffled Valve Covers - HZ-9237
- 12 Steel Valve Cover Wing Nuts - HZ-4137
- 12 Steel Valve Cover Mini Tabs - HZ-9067
- 2 Steel Push-In Style Breather Caps - HZ-4870
- 2 Rubber Push-In Style Breather Grommets - HZ-4878



HZ-3025-C
HZ-3025-PBK

MOPAR SMALL BLOCK

Part #	Engine	Type	Finish
HZ-3029-C	64-73 Chrysler 318-340-360	Smooth	Chrome
HZ-3029-PBK		Smooth	Black

Kit Includes:

- 1 Pair Steel Baffled Valve Covers - HZ-9298
- 10 Steel Valve Cover Wing Nuts - HZ-4137
- 10 Steel Valve Cover Mini Tabs - HZ-9067
- 2 Steel Push-In Breather Caps - HZ-4870
- 2 Rubber Push-In Breather Grommets - HZ-4878



HZ-3029-C **HZ-3029-PBK**

PONTIAC V8

Part #	Engine	Type	Finish
HZ-3030-C	1959-77 Pontiac 326-350-389-400-421-425-455	Tall Smooth	Chrome
HZ-3030-PBK		Tall Smooth	Black

Kit Includes:

- 1 Pair Steel Baffled Valve Covers - HZ-9300
- 8 Steel Valve Cover Wing Nuts - HZ-4138
- 8 Steel Valve Cover Spreader Bars - HZ-9641
- 1 Steel Push-In Breather Cap - HZ-4870
- 1 Rubber Push-In Breather Grommet - HZ-4878
- 1 Rubber PCV Grommet - HZ-4998



HZ-3030-C **HZ-3030-PBK**

ALUMINUM DRESS UP KITS

CHEVY SMALL BLOCK



HZ-6720-3-POL Polished
HZ-6720-3-PBK Black
 TALL H: 3-11/16"

KIT PART #

HZ-6720-3-POL-KIT
HZ-6720-3-PBK-KIT

HZ-6031-3-POL Polished
HZ-6031-3-PBK Black
 SHORT H: 2-9/16"

KIT PART #

HZ-6031-3-POL-KIT
HZ-6031-3-PBK-KIT



HZ-6061-3-POL Polished
HZ-6061-3-PBK Black

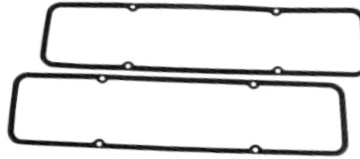

HZ-7484



HZ-4879



HZ-6119-PBK Black
HZ-6119-POL Polished



HZ-6120-PBK Black
HZ-6120-POL Polished

CHEVY SMALL BLOCK CENTER BOLT



HZ-8033-3-POL Polished
HZ-8033-3-PBK Black
 TALL H: 3-11/16"

KIT PART #

HZ-8033-3-POL-KIT
HZ-8033-3-PBK-KIT

HZ-6991-3-POL Polished
HZ-6991-3-PBK Black
 SHORT H: 2-3/8"

KIT PART #

HZ-6991-3-POL-KIT
HZ-6991-3-PBK-KIT



HZ-6061-3-POL Polished
HZ-6061-3-PBK Black

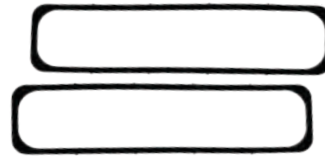

HZ-7488



HZ-4879



HZ-6119-PBK Black
HZ-6119-POL Polished



HZ-6120-PBK Black
HZ-6120-POL Polished

CHEVY BIG BLOCK



HZ-8051-3-POL Polished
HZ-8051-3-PBK Black
 TALL H: 3-11/16"

KIT PART #

HZ-8051-3-POL-KIT
HZ-8051-3-PBK-KIT



HZ-6061-3-POL Polished
HZ-6061-3-PBK Black



HZ-7485



HZ-4879



HZ-6119-PBK Black
HZ-6119-POL Polished



HZ-6120-PBK Black
HZ-6120-POL Polished

FORD SMALL BLOCK



HZ-6728-3-POL Polished
HZ-6728-3-PBK Black
 TALL H: 3-13/16"

KIT PART #

HZ-6728-3-POL-KIT
HZ-6728-3-PBK-KIT



HZ-6061-3-POL Polished
HZ-6061-3-PBK Black



HZ-7486



HZ-4879



HZ-6119-PBK Black
HZ-6119-POL Polished



HZ-6120-PBK Black
HZ-6120-POL Polished

STEEL TIMING CHAIN COVERS

Will not fit LT1 engines & will not clear double roller timing chains without machining

CHEVY BIG BLOCK



Cover Only

Timing Cover Kit

- HZ-4935-C-KIT** Chrome
- HZ-4935-PBK-KIT** Black
- HZ-4935-PO-KIT** Orange
- HZ-4935-R-KIT** Raw
- HZ-4935-Z-KIT** Zinc

-
- HZ-4935-C** (COVER ONLY) Chrome
 - HZ-4935-PBK** (COVER ONLY) Black EDP
 - HZ-4935-PO** (COVER ONLY) Orange
 - HZ-4935-R** (COVER ONLY) Raw
 - HZ-4935-Z** (COVER ONLY) Zinc
- 1966-90 Chevy Big Block**
(396-454)

CHEVY SMALL BLOCK



Cover Only

Timing Cover Kit

- HZ-4934-PBK-L** Black(5")
 - HZ-4934-PBK-T** Black(4-1/4")
- TAB MEASURES FROM TAB TO TOP OF COVER
- 1955-95 Chevy Small Block**
Timing Tab Attached

- HZ-4934-1-C** Chrome (COVER ONLY)
- HZ-4934-1-PBK** Black (COVER ONLY)
- HZ-4934-1-PO** Orange (COVER ONLY)
- HZ-4934-1-R** Raw (COVER ONLY)
- HZ-4934-1-Z** Zinc (COVER ONLY)

- HZ-4934-1-C-KIT** Chrome
- HZ-4934-1-PBK-KIT** Black
- HZ-4934-1-PO-KIT** Orange
- HZ-4934-1-R-KIT** Raw
- HZ-4934-1-Z-KIT** Zinc

1955-95 Chevy Small Block
Fits Roller Cam

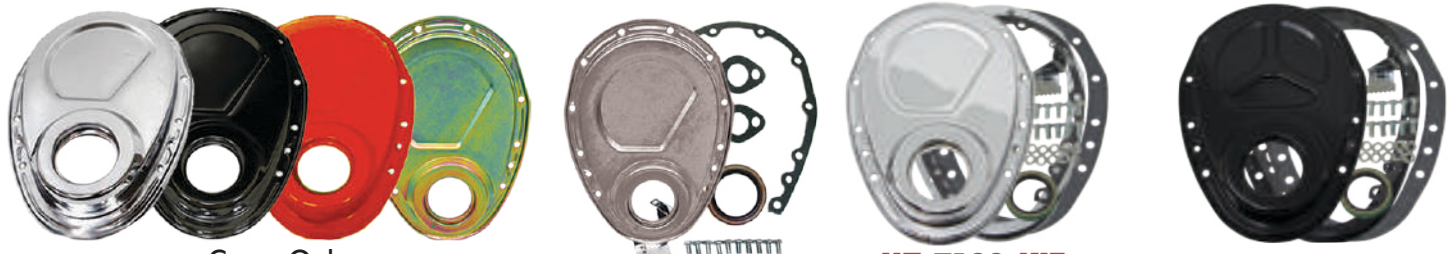

Cover Only

Timing Cover Kit

HZ-7122-KIT

HZ-7123-PBK-KIT

- HZ-4934-C** (COVER ONLY) Chrome
- HZ-4934-PBK** (COVER ONLY) Black EDP
- HZ-4934-PO** (COVER ONLY) Orange
- HZ-4934-R** (COVER ONLY) Raw
- HZ-4934-Z** (COVER ONLY) Zinc

- HZ-4934-C-KIT** Chrome
- HZ-4934-PBK-KIT** Black
- HZ-4934-PO-KIT** Orange
- HZ-4934-R-KIT** Raw
- HZ-4934-Z-KIT** Zinc

- HZ-7122-C-KIT** Chrome
 - HZ-7122-PBK-KIT** Black EDP
- 1955-95 Chevy Small Block**
Two-Piece

1955-95 Chevy Small Block

-
- HZ-7123-C-KIT** Chrome
 - HZ-7123-PBK-KIT** Black EDP
- 1955-95 Chevy Small Block**
Two-Piece Fits Roller Cam

STEEL TIMING CHAIN COVERS

CHEVY BIG BLOCK



BBC Timing Cover Gen 5
HZ-8268-POL Polished
HZ-8268-PBK Black
 Gen 5

LS



LS Timing Cover - Two Piece
HZ-6008-POL Polished
HZ-6008-PBK Black
HZ-6008-COP Copper
 With Cam Sensor Hole
****HZ-6009-POL** Polished
****HZ-6009-PBK** Black
****HZ-6009-COP** Copper
 without Cam Sensor Hole
 **Does not include cam sensor hole.

MOPAR BIG BLOCK



1958-79 Mopar Big Block
HZ-9392-C-KIT Chrome
HZ-9392-PBK-KIT Black EDP

ALUMINUM TIMING CHAIN COVERS

Will not fit LT1 engines & will not clear double roller timing chains without machining

CHEVY BIG BLOCK



HZ-8267-POL-KIT Polished
HZ-8267-POL Polished (COVER ONLY)
HZ-8267-COP-KIT Copper
HZ-8267-COP Copper (COVER ONLY)
 1966-90 Chevy Big Block
 (396-454)

CHEVY SMALL BLOCK



Cover Only **Timing Cover Kit**
HZ-6010-POL-KIT Polished
HZ-6010-C-KIT Chrome
HZ-6010-PBK-KIT Black
HZ-6010-COP-KIT Copper
HZ-6010-POL Polished (COVER ONLY)
HZ-6010-C Chrome (COVER ONLY)
HZ-6010-PBK Black (COVER ONLY)
HZ-6010-COP Copper (COVER ONLY)
 1955-95 Chevy Small Block



Timing Cover Kit
HZ-5258-S-KIT Silver
HZ-5258-PBK-KIT Black
HZ-5258-PBL-KIT Blue
HZ-5258-RED-KIT Red
 1955-95 Chevy Small Block
Fits Roller Cam

TIMING TABS



HZ-4961-C
HZ-4961-PBK
 BBC Chrome
 Steel w/ Pointer
Balancer 8"



HZ-4960-C
HZ-4960-PBK
 SBC Chrome
 Steel w/ Pointer
Balancer 8"



HZ-9178-C
HZ-9178-PBK
 SBC Chrome
 Adjustable w/ Pointer
Balancer 7"



HZ-9179-C
HZ-9179-PBK
 SBC Chrome
 Adjustable w/ Pointer
Balancer 8"



HZ-8273-POL
 BBC Polished
 Aluminum
Balancer 8"



HZ-6041-POL
HZ-6041-C
 SBC Aluminum
Balancer 6 7/8"

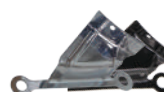

HZ-9393-C
HZ-9393-PBK
 Mopar Steel w/ Pointer
Balancer 8"



HZ-9180-C
HZ-9180-PBK
 BBC Chrome
 Steel w/ Pointer
Balancer 8"

CHEVY BIG BLOCK STOCK OIL PANS

ENGINE	YEAR	DIPSTICK	QTS	PICKUP	SUMP	GASKET	HARDWARE
396-402-427-454	1965-90	Passenger	4	HZ-9011	Rear	HZ-7488	HZ-9903



- HZ-9294-C** Chrome
- HZ-9294-PBK** Black
- HZ-9294-PO** Orange
- HZ-9294-Z** Zinc
- HZ-9294-R** Raw



Chevy big block stock capacity oil pan. You can use the original oil pump pickup. This oil pan does not fit Gen V motors with a one-piece rear main seal or 1962-67 Chevy II with steering behind the crossmember. **Oil pan is baffled.**

ENGINE	YEAR	DIPSTICK	QTS	PICKUP	SUMP	GASKET	HARDWARE
396-402-427-454	1965-90	Passenger	6	HZ-9011	Rear	HZ-7488	HZ-9903



- HZ-9394-C** Chrome
- HZ-9394-PBK** Black
- HZ-9394-Z** Zinc
- HZ-9394-R** Raw



Chevy big block EDP black truck oil pan. Has a 2-piece rear seal. It is constructed of high quality steel and features a rear sump design with a dipstick provision on the passenger side. Works with 2WD and 4WD trucks. **Oil pan is baffled.**

CHEVY BIG BLOCK RACING OIL PANS

ENGINE	YEAR	DIPSTICK	QTS	PICKUP	SUMP	GASKET	HARDWARE
396-402-427-454	1965-90	Passenger	6	HZ-9730	Rear	HZ-7488	HZ-9903



- HZ-9728-C** Chrome
- HZ-9728-PBK** Black
- HZ-9728-PO** Orange
- HZ-9728-Z** Zinc



Chevy big block street/strip racing oil pan. 8-1/4" deep with 1 trap door. **Oil pan is baffled.** *Will not fit 1962-67 Chevy II Nova or V8 Vega/Monza.

CHEVY BIG BLOCK ALUMINUM OIL PANS

ENGINE	YEAR	DIPSTICK	QTS	PICKUP	SUMP	GASKET	HARDWARE
396-402-427-454	1965-90	Passenger	4	Stock	Rear	HZ-7498	Included

Aluminum 1965-90 Chevy BB 396-402-427-454 gen 4 oil pan.



HZ-8440-POL Polished
HZ-8440-PBK Black
HZ-8440-COP Copper



Inside View



ENGINE	YEAR	DIPSTICK	QTS	PICKUP	SUMP	GASKET	HARDWARE
427-454-502	91-Up	Passenger	4	Stock	Rear	HZ-7478	Included

Aluminum 1991-up Chevy BB 396-402-427-454 gen 5, 6 oil pan.



HZ-8441-POL Polished
HZ-8441-PBK Black
HZ-8441-COP Copper



Inside View



CHEVY SMALL BLOCK RACING OIL PANS

ENGINE	YEAR	DIPSTICK	QTS	PICKUP	SUMP	GASKET	HARDWARE
283-305-327-350-400	1958-79	Driver	7	HZ-7102 or HZ-7103	Rear	HZ-7489	HZ-9901

Chevy small block Champ style racing oil pan. 7" deep with 6 trap doors, 2 runners and 3 crank scrapers. Fits using the stock starter. Fits engine with two-piece rear main seal. **Oil pan is baffled.**

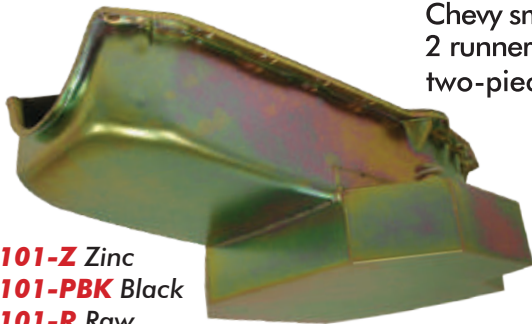

HZ-7101-Z Zinc
HZ-7101-PBK Black
HZ-7101-R Raw

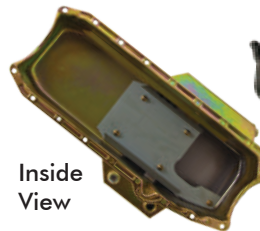

Inside View



ENGINE	YEAR	DIPSTICK	QTS	PICKUP	SUMP	HARDWARE
305-427	1980-85	Passenger	7	HZ-7102 or HZ-7103	Rear	HZ-9901

Steel 1980-85 Chevy SB 305-427 Road Racing Oil Pan with Windage Tray



HZ-7202-Z Zinc
HZ-7202-PBK Black



Inside View

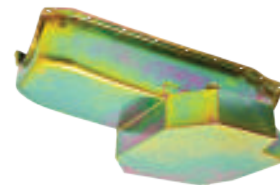

CHEVY SMALL BLOCK RACING OIL PANS

ENGINE	YEAR	DIPSTICK	QTS	PICKUP	SUMP	GASKET	HARDWARE
283-305-327-350-400	1986-02	Passenger	7	HZ-7102 or HZ-7103	Rear	HZ-7497	HZ-9901

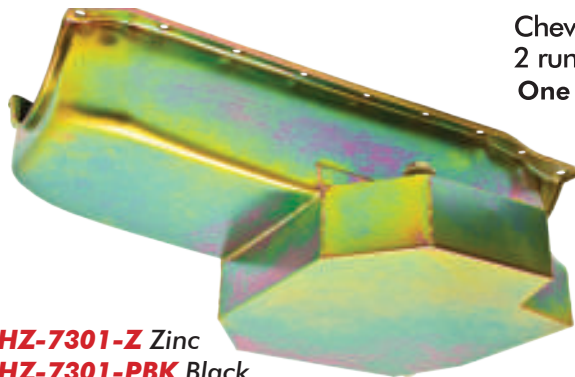

HZ-7301-Z Zinc
HZ-7301-PBK Black
HZ-7301-R Raw

Chevy small block Champ style racing oil pan. 7" deep with 6 trap doors, 2 runners and 3 crank scrapers. Fits using the stock starter. Fits engine with One piece rear main seal. **Oil pan is baffled.**



Inside View

ENGINE	YEAR	DIPSTICK	QTS	PICKUP	SUMP	GASKET	HARDWARE
283-305-327-350-400	1958-79	Driver	6	HZ-7106	Rear	HZ-7489	HZ-9901

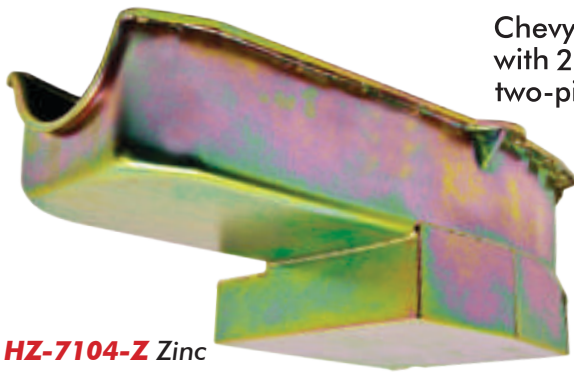

HZ-7104-Z Zinc
HZ-7104-PBK Black
HZ-7104-R Raw

Chevy small block circle track racing claimer style oil pan. 7-1/4" deep with 2 trap doors and fits using the stock starter. Fits engine with two-piece rear main seal. **Oil pan is baffled.**



Inside View

ENGINE	YEAR	DIPSTICK	QTS	PICKUP	SUMP	GASKET	HARDWARE
283-305-327-350-400	1958-79	Driver	6	HZ-7106	Rear	HZ-7489	HZ-9901

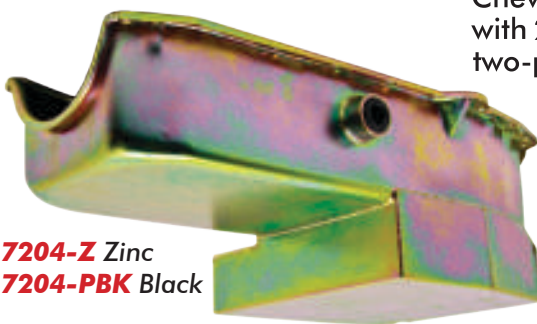

HZ-7204-Z Zinc
HZ-7204-PBK Black

Chevy small block circle track racing claimer style oil pan. 7-1/4" deep with 2 trap doors and fits using the stock starter. Fits engine with two-piece rear main seal. **Oil pan is baffled.**

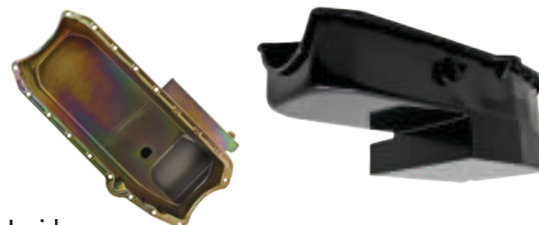

Inside View

** Includes Inspection Bung

CHEVY SMALL BLOCK RACING OIL PANS

ENGINE	YEAR	DIPSTICK	QTS	PICKUP	SUMP	GASKET	HARDWARE
283-305-327-350-400	1958-79	Driver	8	HZ-7114	Rear	HZ-7489	HZ-9901



HZ-7113-Z Zinc
HZ-7113-PBK Black

Chevy small block circle track racing oil pan. 7-1/4" deep with 2 trap doors, crankshaft scrapper and removable tray. Fits using the stock starter. Fits engine with two-piece rear main seal. **Oil pan is baffled.**

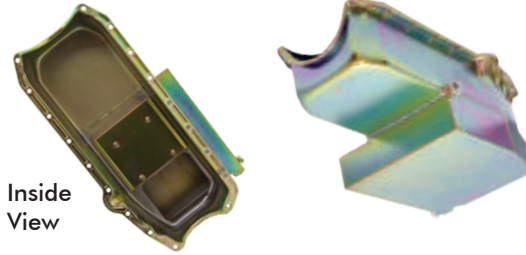

Inside View

ENGINE	YEAR	DIPSTICK	QTS	PICKUP	SUMP	GASKET	HARDWARE
283-305-327-350-400	1980-85	Passenger	6	HZ-7106	Rear	HZ-7496	HZ-9901

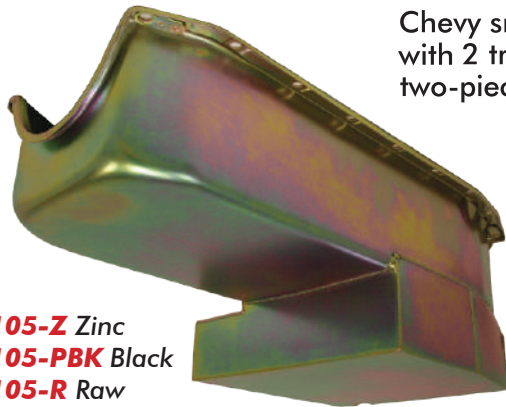

HZ-7105-Z Zinc
HZ-7105-PBK Black
HZ-7105-R Raw

Chevy small block circle track racing claimer style oil pan. 7 1/4" deep with 2 trap doors and fits using the stock starter. Fits engine with two-piece rear main seal. **Oil pan is baffled.**



Inside View

ENGINE	YEAR	DIPSTICK	QTS	PICKUP	SUMP	GASKET	HARDWARE
283-305-327-350-400	1958-79	Driver	4	HZ-7106	Rear	HZ-7489	HZ-9901

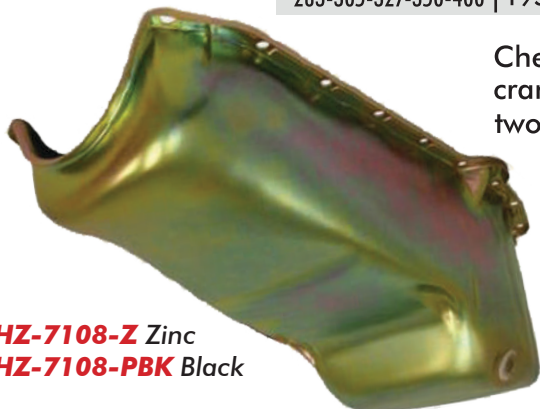

HZ-7108-Z Zinc
HZ-7108-PBK Black

Chevy small block High Performance oil pan. Features 2 trap doors, crank scrapper with windage tray and reinforced rails. Fits engine with two-piece rear main seal. **Oil pan is baffled.**

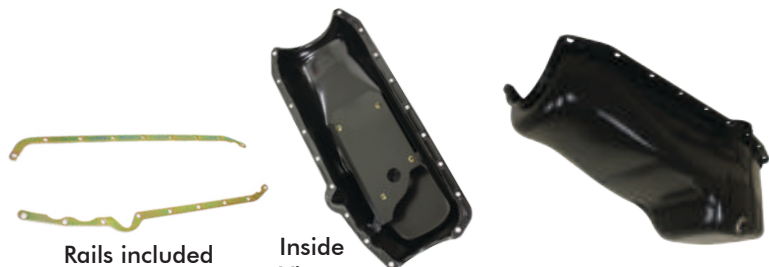

Rails included

Inside View

*Will not fit 1962-67 Chevy II Nova or V8 Vega/Monza.

CHEVY SMALL BLOCK RACING OIL PANS

ENGINE	YEAR	DIPSTICK	QTS	PICKUP	SUMP	GASKET	HARDWARE
305-327-350	1980-85	Passenger	4	HZ-7106	Rear	HZ-7496	HZ-9901

Chevy small block High Performance oil pan. Features 2 trap doors, crank scraper with windage tray and reinforced rails. Fits engine with two-piece rear main seal. **Oil pan is baffled.**



HZ-7208-Z Zinc
HZ-7208-PBK Black
HZ-7208-R Raw



Rails included
Inside View

ENGINE	YEAR	DIPSTICK	QTS	PICKUP	SUMP	GASKET	HARDWARE
1958 79 283-305-327-350-400	1962-67 Nova/Chevy II	Driver	6	HZ-9727	Rear	HZ-7489	HZ-9901

Chevy Small Block street/strip racing oil pan. 8-1/4 Deep. Will not work on applications with power steering. Fits engine with two-piece rear main seal. Notched sump for clearing the steering linkage. **Oil pan is baffled.**



HZ-7480-C Chrome
HZ-7480-PBK Black
HZ-7480-Z Zinc
HZ-7480-R Raw

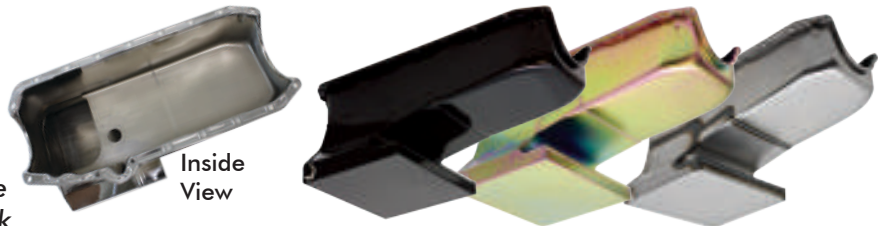

Inside View

* Will not work on applications with power steering.

ENGINE	YEAR	DIPSTICK	QTS	PICKUP	SUMP	GASKET	HARDWARE
1980-85 305-400	1962-67 Nova/Chevy II	Passenger	6	HZ-9727	Rear	HZ-7496	HZ-9901

Chevy Small Block street/strip racing oil pan. 8 1/4 Deep. Fits engine with Two-piece rear main seal. Will not work on applications with power steering. Notched sump for clearing the steering linkage. **Oil pan is baffled.**



HZ-7481-C Chrome
HZ-7481-PBK Black
HZ-7481-Z Zinc



Inside View

* Will not work on applications with power steering.

CHEVY SMALL BLOCK RACING OIL PANS

ENGINE	YEAR	DIPSTICK	QTS	PICKUP	SUMP	GASKET	HARDWARE
1986-02 305-400	1962-67 Nova/Chevy II	Passenger	6	HZ-9727	Rear	HZ-7497	HZ-9901

Chevy Small Block street/strip racing oil pan. 8-1/4 Deep. Will not work on applications with power steering. Fits engine with One-piece rear main seal. Notched sump for clearing the steering linkage. **Oil pan is baffled.**



HZ-7482-C Chrome
HZ-7482-PBK Black
HZ-7482-Z Zinc



Inside View

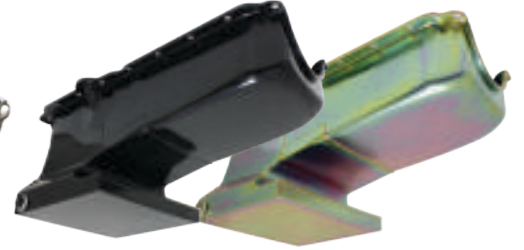

* Will not work on applications with power steering.

ENGINE	YEAR	DIPSTICK	QTS	PICKUP	SUMP	GASKET	HARDWARE
283-305-327-350-400	1958-79	Driver	7	HZ-9727	Rear	HZ-7489	HZ-9901

Chevy small block street/strip racing oil pan. 7 quart capacity. 8-1/4" deep with 1 trap door. Fits engine with Two-piece rear main seal. **Oil pan is baffled.**



HZ-9725-C Chrome
HZ-9725-PBK Black
HZ-9725-Z Zinc
HZ-9725-PO Orange

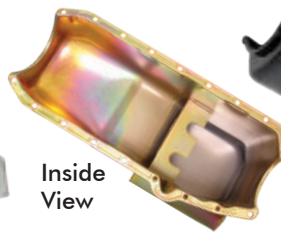

Inside View



** Does not fit 1962-1967 Chevy II or Vega Monza V8.

ENGINE	YEAR	DIPSTICK	QTS	PICKUP	SUMP	GASKET	HARDWARE
305-350	1980-85	Passenger	7	HZ-9727	Rear	HZ-7496	HZ-9901

Chevy Small Block street/strip racing oil pan. 8-1/4 Deep. Fits engine with two-piece rear main seal. **Oil pan is baffled.**



HZ-9731-C Chrome
HZ-9731-PBK Black
HZ-9731-Z Zinc



Inside View



CHEVY SMALL BLOCK RACING OIL PANS

ENGINE	YEAR	DIPSTICK	QTS	PICKUP	SUMP	GASKET	HARDWARE
305-350	1986-02	Passenger	7	HZ-9727	Rear	HZ-7497	HZ-9901



HZ-9732-C Chrome
HZ-9732-PBK Black
HZ-9732-Z Zinc

Chevy small block street/strip racing oil pan. 8-1/4" deep with 1 trap door. Fits engine with One-piece rear main seal. **Oil pan is baffled.**

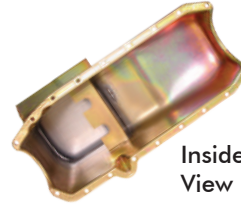

Inside View



CHEVY SMALL BLOCK OEM STYLE OIL PANS

ENGINE	YEAR	DIPSTICK	QTS	PICKUP	SUMP	GASKET	HARDWARE
283-305-327-350-400	1958-79	Driver	4	Stock	Rear	HZ-7489	HZ-9901

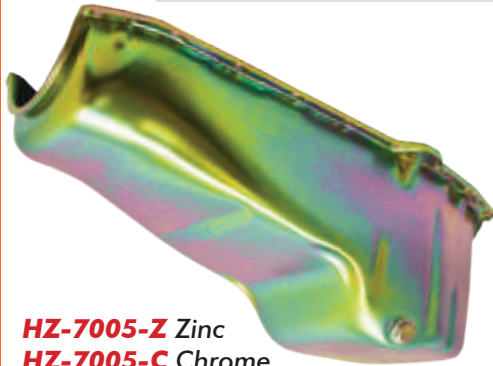

HZ-7005-Z Zinc
HZ-7005-C Chrome
HZ-7005-PBK Black
HZ-7005-PO Orange
HZ-7005-R Raw



Inside View

Chevy small block stock OEM style replacement Steel oil pan. The oil pan is notched on the front sump for clearance of the crossmember. Fits engine with two-piece rear main seal. **Oil pan is baffled.**

ENGINE	YEAR	DIPSTICK	QTS	PICKUP	SUMP	GASKET	HARDWARE
283-305-327-350-400	1980-85	Passenger	4	Stock	Rear	HZ-7496	HZ-9901



HZ-7006-PBK Black
HZ-7006-C Chrome
HZ-7006-PO Orange
HZ-7006-R Raw
HZ-7006-Z Zinc



Inside View

CHEVY SMALL BLOCK OEM STYLE OIL PANS

ENGINE	YEAR	DIPSTICK	QTS	PICKUP	SUMP	GASKET	HARDWARE
283-305-327-350-400	1986-02	Passenger	4	Stock	Rear	HZ-7497	HZ-9901



- HZ-7007-C** Chrome
- HZ-7007-PBK** Black
- HZ-7007-PO** Orange
- HZ-7007-R** Raw

CHEVY SMALL BLOCK STOCK OIL PANS

ENGINE	YEAR	DIPSTICK	QTS	PICKUP	SUMP	GASKET	HARDWARE
262-267-283-305-327-350-400	1958-79	Driver	4	Stock	Rear	HZ-7489	HZ-9901

Chevy small block stock capacity oil pan. Fits engine with two-piece rear main seal. **Oil pan is baffled.**



- HZ-9005-Z** Zinc
- HZ-9005-C** Chrome
- HZ-9005-PBK** Black
- HZ-9005-PO** Orange
- HZ-9005-R** Raw

* Will not fit V8 Vega, Monza, 302 High Performance engines or 1962-67 Chevy II Novas and some Corvettes.

ENGINE	YEAR	DIPSTICK	QTS	PICKUP	SUMP	GASKET	HARDWARE
305-350	1980-85	Passenger	4	Stock	Rear	HZ-7496	HZ-9901

Chevy small block stock capacity oil pan. Fits engine with two-piece rear main seal. **Oil pan is baffled.**



- HZ-9092-PBK** Black
- HZ-9092-C** Chrome
- HZ-9092-PO** Orange
- HZ-9092-R** Raw

* Will not fit V8 Vega, Monza, 302 High Performance engines or 1962-67 Chevy II Novas and some Corvettes.

CHEVY SMALL BLOCK STOCK OIL PANS

ENGINE	YEAR	DIPSTICK	QTS	PICKUP	SUMP	GASKET	HARDWARE
305-350	1986-02	Passenger	4	Stock	Rear	HZ-7497	HZ-9901



Chevy small block oil pan. Fits engine with one-piece rear main seal. Oil pan is baffled.



Inside View

- HZ-9414-C** Chrome
- HZ-9414-PBK** Black
- HZ-9414-PO** Orange
- HZ-9414-Z** Zinc
- HZ-9414-R** Raw

*Will not fit V8 Vega, Monza, 302 High Performance engines or 1962-67 Chevy II Novas and some Corvettes.

CHEVY SMALL BLOCK ALUMINUM OIL PANS

ENGINE	YEAR	DIPSTICK	QTS	PICKUP	SUMP	GASKET	HARDWARE
262-267-283-305-327-350-400	1958-79	Driver	4	Stock	Rear	HZ-7489	Included



Chevy small block finned aluminum oil pan. Use early-style thick front seal. Comes with bolt kit. Fits engine with two-piece rear main seal. Will not accommodate windage tray. Oil pan is not baffled.



Inside View

- HZ-8442-POL** Polished
- HZ-8442-PBK** Black
- HZ-8442-COP** Copper

*Will not fit V8 Vega, Monza, 302 High Performance engines or 1962-67 Chevy II Novas and some Corvettes.

ENGINE	YEAR	DIPSTICK	QTS	PICKUP	SUMP	GASKET	HARDWARE
305-350	1980-85	Passenger	4	Stock	Rear	HZ-7496	Included

Chevy small block stock capacity aluminum retro finned. Fits engine with two-piece rear main seal. Will not accommodate windage tray. Oil pan is not baffled.



Inside View

- HZ-8443-POL** Polished
- HZ-8443-PBK** Black
- HZ-8443-COP** Copper

*Will not fit V8 Vega, Monza, 302 High Performance engines or 1962-67 Chevy II Novas and some Corvettes.

CHEVY SMALL BLOCK ALUMINUM OIL PANS

ENGINE	YEAR	DIPSTICK	QTS	PICKUP	SUMP	GASKET	HARDWARE
305-350 V8	1986-02	Passenger	4	Stock	Rear	HZ-7497	Included

Chevy small block finned aluminum oil pan. Fits engine with one-piece rear main seal. Will not accommodate windage tray. Oil pan is not baffled.



HZ-8444-POL Polished
HZ-8444-PBK Black
HZ-8444-COP Copper



Inside View



*Will not fit V8 Vega, Monza, 302 High Performance engines or 1962-67 Chevy II Novas and some Corvettes.

CHEVY LS OIL PANS

ENGINE	YEAR	DIPSTICK	QTS	PICKUP	SUMP	GASKET	HARDWARE
OEM LS Engine/Swap	1965-72	N/A	7	HZ-9735	Rear	HZ-7499	HZ-9906

Fits 1968-'72 Nova, 1965-'72 Chevelle, 1967-'69 Camaro, Can also be used on other applications check dimensions for clearance. Engine application: GM LS Series. Features wet sump, 7 quart capacity, 6" deep baffled trap-door baffling improving oil control and -10AN fittings for remote filter, uses stock dipstick



Straight Fitting

HZ-9733-C Chrome
HZ-9733-PBK Black
HZ-9733-Z Zinc
HZ-9733-R Raw



Straight Fitting

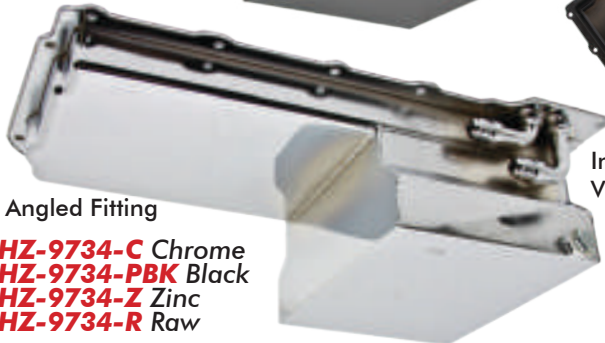

Angled Fitting

HZ-9734-C Chrome
HZ-9734-PBK Black
HZ-9734-Z Zinc
HZ-9734-R Raw



Inside View



Angled Fitting

ENGINE	YEAR	DIPSTICK	QTS	PICKUP	SUMP	GASKET	HARDWARE
OEM LS Engine/Swap	1965-72	N/A	7	HZ-9735	Rear	HZ-7499	HZ-9906



Adapter Fitting

HZ-9736-C Chrome
HZ-9736-PBK Black
HZ-9736-Z Zinc
HZ-9736-R Raw



Inside View



Filter Adapter Fitting

FORD BIG BLOCK STOCK OIL PANS

ENGINE	YEAR	DIPSTICK	QTS	PICKUP	SUMP	GASKET	HARDWARE
352-390-406-427-428 FE	1958-76	Timing Cover	4	Stock	Front	Stock	HZ-9905

Ford FE stock capacity oil pan. Does not fit trucks, vans, or 428CJ. Oil pan is baffled.



Inside View

- HZ-9330-C** Chrome
- HZ-9330-PBK** Black
- HZ-9330-PBL** Blue
- HZ-9330-Z** Zinc
- HZ-9330-R** Raw

ENGINE	YEAR	DIPSTICK	QTS	PICKUP	SUMP	GASKET	HARDWARE
429-460 V8	1968-78	Timing Cover	4	Stock	Front	Stock	HZ-9905

Ford big block chrome oil pan. Fits most front sump production chassis except Mustang II. Oil pan is not baffled.



Inside View

- HZ-9343-C** Chrome
- HZ-9343-PBK** Black
- HZ-9343-Z** Zinc
- HZ-9343-R** Raw

FORD SMALL BLOCK RACING OIL PANS

ENGINE	YEAR	DIPSTICK	QTS	PICKUP	SUMP	GASKET	HARDWARE
260-289-302	1965-87	Timing Cover	7	HZ-7421	Front	HZ-7473	HZ-9904

Ford small block street/strip racing oil pan. Also fits two wheel drive trucks and vans. Factory front sump applications only. Oil pan is baffled. Dimensions: 10"(L) x 12.5"(W) x 9"(D).



Inside View



- HZ-7474-C** Chrome
- HZ-7474-PBK** Black
- HZ-7474-Z** Zinc
- HZ-7474-R** Raw

FORD SMALL BLOCK RACING OIL PANS

ENGINE	YEAR	DIPSTICK	QTS	PICKUP	SUMP	GASKET	HARDWARE
351W	1965-87 Windsor V8	Timing Cover	7	HZ-7422	Front	HZ-7471	HZ-9904

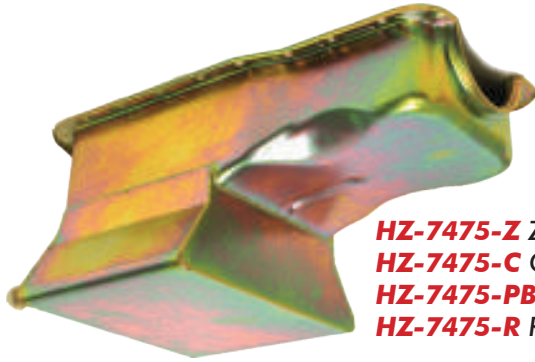

HZ-7475-Z Zinc
HZ-7475-C Chrome
HZ-7475-PBK Black
HZ-7475-R Raw

Ford small block street/strip racing oil pan. Also fits two wheel drive trucks and vans. Factory front sump applications only. **Oil pan is baffled.** Dimensions: 10"(L) x 12.5"(W) x 9"(D).

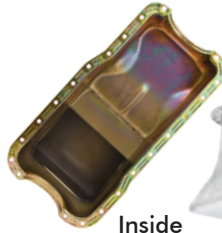

Inside View



ENGINE	YEAR	DIPSTICK	QTS	PICKUP	SUMP	GASKET	HARDWARE
5.0L (302)	1979-93 Mustang	Driver	7	HZ-9451	Dual	HZ-7470	HZ-9904



HZ-9450-Z Zinc
HZ-9450-PBK Black

Ford small block street/strip racing oil pan has a 9" deep sump. Fits Fox-Body style. **Oil pan is baffled.**

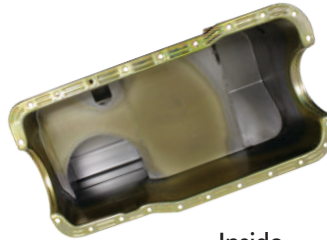

Inside View



***NOTE:** A stock 5.0 dipstick tube can be used (through the block) however it must be installed (pressed in) before the oil pan is bolted up or it will bind. If you want to use the side oil pan bung, you will need to purchase our dipstick kit HZ-9452E and the original oil dipstick location (through the block) must then be plugged.

ENGINE	YEAR	DIPSTICK	QTS	PICKUP	SUMP	GASKET	HARDWARE
351W	1979-93 Mustang	Driver	7	HZ-9449	Dual	HZ-7471	HZ-9904



HZ-9448-Z Zinc
HZ-9448-PBK Black



Inside View



Ford small block street/strip racing oil pan has a 9" deep sump. Fits Fox-Body style. We recommended using a high volume oil pump. **Oil pan is baffled.**

NOTE: A stock 5.0 dipstick tube can be used (through the block) however it must be installed (pressed in) before the oil pan is bolted up or it will bind. If you want to use the side oil pan bung, you will need to purchase our dipstick kit HZ-9452E and the original oil dipstick location (through the block) must then be plugged.

FORD SMALL BLOCK RACING OIL PANS

ENGINE	YEAR	DIPSTICK	QTS	PICKUP	SUMP	GASKET	HARDWARE
351C-351M-400	1970-82	Timing Cover	8	Stock	Front	HZ-7476	HZ-9904

Ford small block street/strip racing oil pan. Fits passenger cars only. Oil pan is baffled. Dimensions: 8-3/4"(L) x 13-1/4"(W) x 8-1/4"(D).



HZ-9309-C Chrome
HZ-9309-PBK Black
HZ-9309-Z Zinc



Inside View

*Must Use High Volume Oil Pump.
Recommended oil pump: Melling P/N: M-84AHV
Recommended oil pump pickup: Melling P/N: 84-AS1

FORD SMALL BLOCK STOCK OIL PANS

ENGINE	YEAR	DIPSTICK	QTS	PICKUP	SUMP	GASKET	HARDWARE
5.0L (302)	1983-93 Mustang	Timing Cover	4	7427	Dual	HZ-7470	HZ-9904

Ford Mustang stock capacity oil pan. Oil pan is not baffled. Pan has hole for stock low oil sender. If not used, must be plugged with dealer item: E4AZ-6A828A plug and E4AZ-6C626B washer.



HZ-9754-C Chrome
HZ-9754-PBK Black
HZ-9754-Z Zinc
HZ-9754-R Raw



Inside View

ENGINE	YEAR	DIPSTICK	QTS	PICKUP	SUMP	GASKET	HARDWARE
351 Windsor	83-93 351W	Timing Cover	4	7428-PBK	Dual	HZ-7471	HZ-9904

1979-95 Ford 351W 5.8L Oil Pan Fox Body Conversion Kit Fits 1979-95 Mustang and Fox Body Chassis, also fits 1969-97 Production Blocks. This Oil pan has 5 Quart Capacity, Steel Construction, and Dual Sump. Will not clear main girdles and will work with HV oil pump with slight modification.



HZ-9755-C-KIT Chrome
HZ-9755-PBK-KIT Black
HZ-9755-Z-KIT Zinc
HZ-9755-R-KIT Raw



Also Available **HZ-9755-C** Chrome **HZ-9755-PBK** Black
w/out kit **HZ-9755-Z** Zinc **HZ-9755-R** Raw

FORD SMALL BLOCK STOCK OIL PANS

ENGINE	YEAR	DIPSTICK	QTS	PICKUP	SUMP	GASKET	HARDWARE
351W	1969-81	Timing Cover	4	Stock	Front	HZ-7471	HZ-9904



Ford small block stock capacity oil pan. Fits two wheel drive trucks and vans. Factory front sump applications only. **Oil pan is not baffled.**



- HZ-9532-C** Chrome
- HZ-9532-PBK** Black
- HZ-9532-PBL** Blue
- HZ-9532-Z** Zinc
- HZ-9532-R** Raw

ENGINE	YEAR	DIPSTICK	QTS	PICKUP	SUMP	GASKET	HARDWARE
260-289-302	1962-82	Timing Cover	4	HZ-7426	Front	HZ-7473	HZ-9904



Ford small block stock capacity oil pan. Fits two wheel drive trucks and vans. Factory front sump applications only. **Oil pan is not baffled.**



- HZ-9078-C** Chrome
- HZ-9078-PBK** Black
- HZ-9078-PBL** Blue
- HZ-9078-Z** Zinc
- HZ-9078-R** Raw

ENGINE	YEAR	DIPSTICK	QTS	PICKUP	SUMP	GASKET	HARDWARE
351C-351M-400	1970-82 Passenger Cars	Timing Cover	4	Stock	Front	HZ-7476	HZ-9904



Ford small block stock capacity oil pan. Front sump pan for passenger cars only. **Oil pan is baffled.**



- HZ-9310-C** Chrome
- HZ-9310-PBK** Black
- HZ-9310-Z** Zinc
- HZ-9310-R** Raw

FORD SMALL BLOCK ALUMINUM OIL PANS

ENGINE	YEAR	DIPSTICK	QTS	PICKUP	SUMP	GASKET	HARDWARE
260-289-302	1962-82	Timing Cover	4	HZ-7426	Front	HZ-7473	Included



HZ-8445-POL Polished
HZ-8445-PBK Black
HZ-8445-COP Copper

Ford small block finned aluminum stock capacity oil pan. wheel drive trucks and vans. Factory front sump applications only. **Oil pan is not baffled.**



Inside View



FORD SMALL BLOCK TRUCK OIL PANS

ENGINE	YEAR	DIPSTICK	QTS	PICKUP	SUMP	GASKET	HARDWARE
5.8L 351W	1988-97 Trucks/Vans	Timing Cover	4	Stock	Rear	HZ-7471	HZ-9904



HZ-9791-C Chrome
HZ-9791-PBK Black
HZ-9791-Z Zinc

Ford 351W Windsor small block truck oil pan. Rear sump truck. Fits Bronco, F150, F250 Pickup, F350, E150, E250 Vans, E350 and Class C Motorhomes. **Oil pan is not baffled.**



Inside View



ENGINE	YEAR	DIPSTICK	QTS	PICKUP	SUMP	GASKET	HARDWARE
351 Windsor 5.8L	81-87 351W	Driver Side	4	Stock	Rear	HZ-7471	HZ-9904



HZ-8791-C Chrome
HZ-8791-PBK Black
HZ-8791-Z Zinc

Ford 351W Windsor small block truck oil pan. Rear sump truck. Fits Bronco, F150, F250 Pickup, F350, E150, E250 Vans, E350 and Class C Motorhomes. **Oil pan is not baffled.**



Inside View



FORD SMALL BLOCK TRUCK OIL PANS

ENGINE	YEAR	DIPSTICK	QTS	PICKUP	SUMP	GASKET	HARDWARE
4.2L 256-5.0L 302	1980-96 Trucks/Vans	Timing Cover	4	Stock	Rear	HZ-7470	HZ-9904

Ford small block truck oil pan. Fits Bronco, F100, F150, F250 Pickup, F350, E150, E250 Vans, and Class C Motorhomes. Oil pan is not baffled.



HZ-9792-C Chrome
HZ-9792-PBK Black
HZ-97921-Z Zinc



Inside View



HZ-8792-C Chrome
HZ-8792-PBK Black
HZ-8792-Z Zinc



Inside View



GENERAL MOTOR STOCK OIL PANS

ENGINE	YEAR	DIPSTICK	QTS	PICKUP	SUMP	GASKET	HARDWARE
229 V6 3.8L	1980-84	Passenger	4	Stock	Rear	Stock	HZ-9901

Chevy/GM 229 V6 3.8L chrome steel oil pan.



HZ-7459-C Chrome
HZ-7459-PBK Black
HZ-7459-Z Zinc
HZ-7459-R Raw



Inside View



GENERAL MOTOR STOCK OIL PANS

ENGINE	YEAR	DIPSTICK	QTS	PICKUP	SUMP	GASKET	HARDWARE
V6 2.8L	1981-89	Passenger	4	Stock	Rear	Stock	HZ-9901



Chevy/GM stock capacity chrome steel oil pan fits engines with a 1-piece rear main seal, 1982-1986 2WD S-10 pickup trucks, 1981-1989 2WD S-15 pickup trucks, 1982-1986 Chevy Camaros and Pontiac Firebirds. **Oil pan is baffled.**

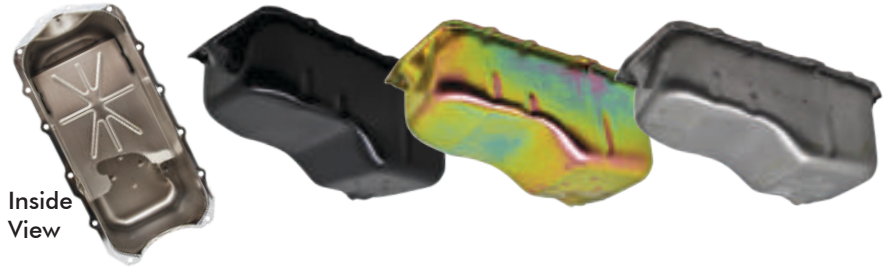

- HZ-7465-C** Chrome
- HZ-7465-PBK** Black
- HZ-7465-Z** Zinc
- HZ-7465-R** Raw

ENGINE	YEAR	DIPSTICK	QTS	PICKUP	SUMP	GASKET	HARDWARE
262 V6 4.3L	1986-95	Passenger	4	Stock	Rear	Stock	HZ-9901



Chevy/GM steel stock capacity oil pan fits engines with a one-piece rear main seal. **Oil pan is baffled.**



- HZ-7466-C** Chrome
- HZ-7466-PBK** Black
- HZ-7466-Z** Zinc
- HZ-7466-R** Raw

ENGINE	YEAR	DIPSTICK	QTS	PICKUP	SUMP	GASKET	HARDWARE
265-301-326-350-389 -400-421-428-455	1959-81	Passenger	4	Stock	Rear	Stock	HZ-9903

Pontiac steel oil pan. **Oil pan is baffled.**



- HZ-9337-C** Chrome
- HZ-9337-PBK** Black
- HZ-9337-Z** Zinc
- HZ-9337-R** Raw

* Also available without baffle. **HZ-9337-RA**

GENERAL MOTOR STOCK OIL PANS

ENGINE	YEAR	DIPSTICK	QTS	PICKUP	SUMP	GASKET	HARDWARE
231 V6 14 Bolt	1975-83	Stock	4	Stock	Front	Stock	HZ-9905



Buick chrome oil pan fits engines with 14 bolt pattern. Must use first design oil pump pickup.



Inside View



- HZ-9590-C** Chrome
- HZ-9590-Z** Zinc
- HZ-9590-R** Raw

ENGINE	YEAR	DIPSTICK	QTS	PICKUP	SUMP	GASKET	HARDWARE
330-350-400-425-455	1964-80	Driver	4	9399-PBK	Rear	Stock	HZ-9901



Oldsmobile chrome oil pan. Will not fit 1975 400 engines. Oil pan is baffled.

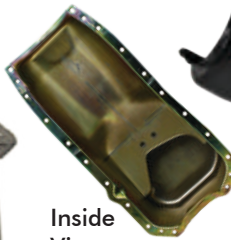

Inside View



- HZ-9397-C** Chrome
- HZ-9397-PBK** Black
- HZ-9397-Z** Zinc
- HZ-9397-R** Raw

OLDSMOBILE RACING OIL PANS

ENGINE	YEAR	DIPSTICK	QTS	PICKUP	SUMP	GASKET	HARDWARE
307-455	1965-UP	Driver	8	9399-PBK	Rear	Stock	HZ-9901

Oldsmobile oil pan. Will not fit 1975 400 engines Oil pan is baffled.

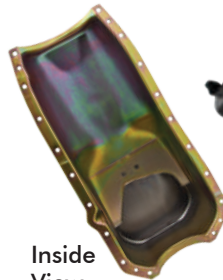

Inside View

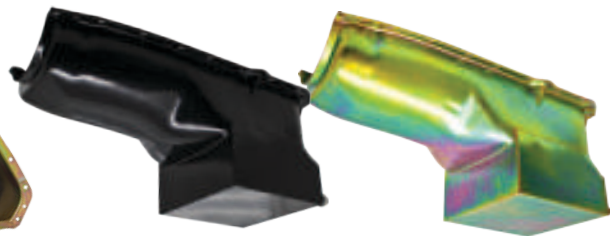

- HZ-9398-C** Chrome
- HZ-9398-PBK** Black
- HZ-9398-Z** Zinc

MOPAR STOCK OIL PANS

ENGINE	YEAR	DIPSTICK	QTS	PICKUP	SUMP	GASKET	HARDWARE
273-318-340	1964-87	Timing Cover	4	Stock	Center	Stock	HZ-9903



Chrysler/Mopar small block oil pan. Will not fit trucks, vans or 360 engines. **Oil pan is not baffled.**



- HZ-9311-C** Chrome
- HZ-9311-PBK** Black
- HZ-9311-Z** Zinc
- HZ-9311-R** Raw

ENGINE	YEAR	DIPSTICK	QTS	PICKUP	SUMP	GASKET	HARDWARE
360	1971-80	Timing Cover	4	Stock	Center	Stock	HZ-9903



Chrysler/Mopar small block chrome oil pan. Will not fit trucks or vans. **Oil pan is not baffled.**



- HZ-9344-C** Chrome
- HZ-9344-PBK** Black
- HZ-9344-Z** Zinc
- HZ-9344-R** Raw

ENGINE	YEAR	DIPSTICK	QTS	PICKUP	SUMP	GASKET	HARDWARE
361-383-400-413-440 B & RB-Hemi 426	1967-87	Block	5	Stock	Center	HZ-7460	HZ-9903



Chrysler/Mopar Hemi big block chrome oil pan. Will not fit trucks or vans. Fits B and E Body Dodge Charger, Coronet, Super Bee, Challenger or Plymouth, GTX and Barracuda. **Oil pan is baffled.**



- HZ-9496-C** Chrome
- HZ-9496-PBK** Black
- HZ-9496-Z** Zinc
- HZ-9496-R** Raw

MOPAR STOCK OIL PANS

ENGINE	YEAR	DIPSTICK	QTS	PICKUP	SUMP	GASKET	HARDWARE
361-383-400-413-440 B & RB-Hemi 426	1967-87	Block	6	Stock	Center	HZ-7460	HZ-9903

Chrysler/Mopar Hemi big block chrome extra capacity oil pan. Comes with oil control baffles and drain plug. Fits B and E Body Dodge Charger, Coronet, Super Bee, Challenger or Plymouth, GTX and Barracuda. **Oil pan is baffled.**



- HZ-9497-C** Chrome
- HZ-9497-PBK** Black
- HZ-9497-Z** Zinc
- HZ-9497-R** Raw

ENGINE	YEAR	DIPSTICK	QTS	PICKUP	SUMP	GASKET	HARDWARE
Hemi 392	1955-58	Block	5	Stock	Rear	Stock	HZ-9903

Chrysler/Mopar chrome OEM style stock capacity oil pan. Includes drain plug. **Oil pan is not baffled.**



- HZ-7477-C** Chrome
- HZ-7477-PBK** Black
- HZ-7477-Z** Zinc
- HZ-7477-R** Raw

MOPAR RACING OIL PANS

ENGINE	YEAR	DIPSTICK	QTS	PICKUP	SUMP	GASKET	HARDWARE
361-383-400-413-440 B & RB-Hemi 426	1967-87	Block	7	7118/7119	Center	HZ-7460	HZ-9903

Chrysler/Mopar Hemi big block zinc street/strip racing oil pan. Features a 7" center sump design. **Oil pan is baffled.**



- HZ-7117-C** Chrome
- HZ-7117-PBK** Black
- HZ-7117-Z** Zinc
- HZ-7117-R** Raw

OIL PAN GASKETS

OIL PAN GASKETS



CHEVY SB 1980-85
TWO PIECE REAR MAIN SEAL
HZ-7496
1 PIECE RUBBER STEEL CORE

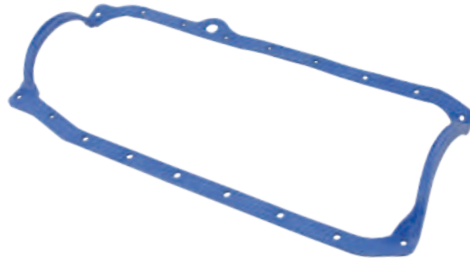

CHEVY SB 1986-02
ONE PIECE REAR MAIN SEAL
HZ-7497
1 PIECE RUBBER STEEL CORE

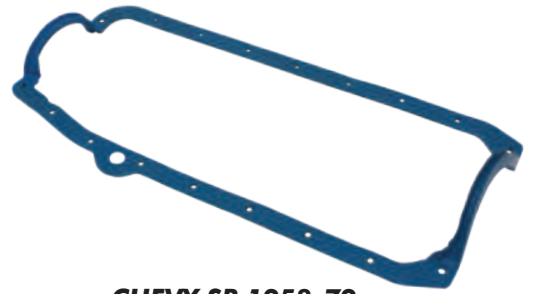

CHEVY SB 1958-79
HZ-7489
1 PIECE RUBBER STEEL CORE



FORD 5.0L 302
1986-1995
HZ-7470
1 PIECE RUBBER STEEL CORE



FORD SB 351W 5.8L
1969-1997
HZ-7471
1 PIECE RUBBER STEEL CORE



FORD SB 260, 289, 302W
1962-87
HZ-7473
1 PIECE RUBBER STEEL CORE



CHEVY BB GEN V-VI
1991-2000
HZ-7478
1 PIECE RUBBER STEEL CORE



CHEVY BB GEN IV
1965-90 454
HZ-7498
1 PIECE RUBBER STEEL CORE



CHEVY LS
1999-2001
HZ-7499
1 PIECE STEEL



FORD 351C -351-400
1970-82
HZ-7476
4 PIECE CORK



MOPAR BB 361 - 440
1957-78
HZ-7460
1 PIECE RUBBER STEEL CORE

OIL PAN PICKUPS

OIL PAN PICKUPS



CHEVY SMALL BLOCK
CIRCLE TRACK STYLE
5/8" DIA. INLET HOLE PUMP
HZ-7102
OIL PAN: HZ-7101



CHEVY SMALL BLOCK
CIRCLE TRACK STYLE
3/4" DIA. INLET HOLE PUMP
HZ-7103
OIL PAN: HZ-7101



CHEVY SMALL BLOCK
CIRCLE TRACK STYLE
1958-1985
HZ-7106
OIL PAN: HZ-7104/7105



CHEVY SMALL BLOCK
CIRCLE TRACK/ RACING STYLE
HZ-7107
OIL PAN: HZ-7104/7108



CHEVY SMALL BLOCK
RACING STYLE
HZ-7110
OIL PAN: HZ-7108/7108-1



CHEVY SMALL BLOCK
CIRCLE TRACK STYLE
HZ-7114
OIL PAN: HZ-7113



CHEVY SMALL BLOCK
1958-02 DRAG RACING STYLE
HZ-9727
OIL PAN: HZ-7480,9725,
9726, 9731, 9732



CHEVY SMALL BLOCK
HIGH VOLUME
HZ-9737
OIL PAN: HZ-9725,
9731,9732



CHEVY SMALL BLOCK OIL
PUMP PICKUP
(FOR H.V VOLUME PUMP)
HZ-7403-Z
OIL PAN: HZ-7401



CHEVY SMALL BLOCK OIL
PUMP PICKUP
(STANDARD VOLUME PUMP)
HZ-7402-Z
OIL PAN: HZ-7401



STEEL CHEVY SMALL
BLOCK OIL PUMP
PICKUP (S.V PUMP)
HZ-7109
OIL PAN: HZ-7108



CHEVY BIG BLOCK
DRAG RACING STYLE
HZ-9730
OIL PAN: HZ-9728/9729



CHEVY BIG BLOCK
STOCK CAPACITY
HZ-9011
OIL PAN: HZ-9294/9294-2



CHEVY/GM
1965-83 V6, V8
STOCK CAPACITY
HZ-9010
OIL PAN: HZ-7005/9005



CHEVY LS
HZ-9735
OIL PAN: HZ-9733/9734



OLDSMOBILE
1964-80, 330-455
HZ-9399
OIL PAN: HZ-9397



1964-80 OLDSMOBILE
MARINE 330-350-400-425-
455 OIL PICKUP
HZ-9400-Z



FORD SMALL BLOCK
260-289-302 FRONT SUMP
DRAG RACING STYLE
HZ-7421
OIL PAN: HZ-7474



FORD SMALL BLOCK
351W FRONT SUMP
DRAG RACING STYLE
HZ-7422
OIL PAN: HZ-7475



FORD SMALL BLOCK
1962-80 FORD SB 260-302
STOCK CAPACITY
HZ-7426
OIL PAN: 8445,9078



FORD SMALL BLOCK
50.1 MUSTANG
STOCK CAPACITY
HZ-7427
OIL PAN: HZ-9754



FORD SMALL BLOCK
351W DUAL SUMP
DRAG RACING STYLE
HZ-9449
OIL PAN: HZ-9448



FORD SMALL BLOCK
260-289-302 FRONT SUMP
DRAG RACING STYLE
HZ-9451
OIL PAN: HZ-9450



1980-96 FORD TRUCK
4.2L 255, 5.0L 302
HZ-7429
OIL PAN: HZ-9792, 8792



1983-93 FORD
MUSTANG 5.8L 351
HZ-7428
OIL PAN: HZ-9755



FORD 1971-82 351M/400
OIL PUMP
SCREEN ASSEMBLY
HZ-7423



MOPAR
3/8" THREADS
B&RB ENGINES 1/2-14
THREADS STOCK 426
HZ-7118/7119
OIL PAN: HZ-7117

OIL PAN HARDWARE & RAILS



**CHEVY SMALL BLOCK
OIL PAN REINFORCED RAILS
1958-79 CHEVY SMALL BLOCK**

HZ-9004-PBK Black
HZ-9004-Z Zinc



**CHEVY SMALL BLOCK
OIL PAN REINFORCED RAILS
1986-02 CHEVY SMALL BLOCK**

HZ-9413-PBK Black
HZ-9413-Z Zinc

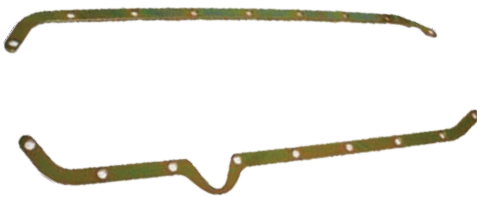

**CHEVY SMALL BLOCK
OIL PAN REINFORCED RAILS
1980-85 CHEVY SMALL BLOCK**

HZ-9091-Z Zinc



**CHEVY / GM 262 4.3L
OIL PAN REINFORCED RAILS
1980-85 CHEVY SMALL BLOCK**

HZ-7467-PBK Black



**OIL PAN/
TRANSMISSION PAN DRAIN PLUG**

HZ-9061-C Chrome **HZ-9061-PBK** Black
HZ-9061-Z Zinc



**MAGNETIC OIL PAN/
TRANSMISSION PAN DRAIN PLUG**

HZ-9063-C Chrome **HZ-9063-PBK** Black
HZ-9063-Z Zinc **HZ-9063-PO** Orange



Chrome
HZ-9901

Chevy SB 90 V6 & Oldsmobile
1/4"-20 x 1/2" (14)
5/16"-18 x 1/2" (4)



HZ-9902-KIT

SBC Silver Zinc
18 Self locking pieces
Includes plug



Chrome
HZ-9903

Chevy BB, Pontiac, Mopar
5/16"-18 x 1/2" (24)
1/4"-20 x 1/2" (4)



Chrome
HZ-9904

Ford 289-351
C/W & AMC 290-401
5/16"-18 x 3/4" (6)
1/4"-20 x 1/2" (18)



Chrome
HZ-9905

Buick V6 & Ford 390-428
5/16"-18 x 3/4 (20)



HZ-9906-SIL

LS1,LS2,LS3 Oil Pan Bolts



HZ-351

Main Cap Stud Ford 351W

OIL PAN HARDWARE & ACCESSORIES

CHEVY/GM FLEX PLATE COVERS

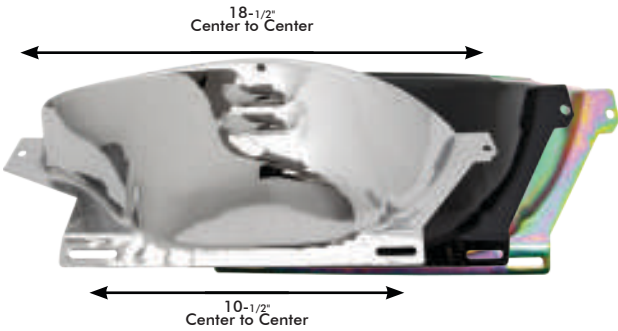

CHEVY / GM 700R4 - STEEL
HZ-9587-C Chrome
HZ-9587-PBK Black
HZ-9587-Z Zinc



CHEVY / GM TURBO TH-350/ TH-400 - STEEL
HZ-9588-C Chrome
HZ-9588-PBK Black
HZ-9588-Z Zinc



CHEVY / GM POWERGLIDE - STEEL
HZ-9417-C Chrome
HZ-9417-PBK Black
HZ-9417-Z Zinc



CHEVY / GM TURBO TH-350/ TH-400 - ALUMINUM
HZ-8607-C Chrome Polished
HZ-8607-POL Polished
HZ-8607-PBK Black
HZ-8607-COP Copper
 Comes w/ 4 bolts and 4 washers.

ALUMINUM TRANSMISSION PANS

Chevy/GM Finned Polished Aluminum Transmission Pans. Comes with drain plug, bolts and gasket. Finned style sump helps to dissipate heat.



CHEVY/GM TURBO TH-350
HZ-8491-KIT-POL Polished
HZ-8491-KIT-PBK Black
HZ-8491-KIT-C Chrome
HZ-8491-KIT-COP Copper

DEPTH: 2-1/4"

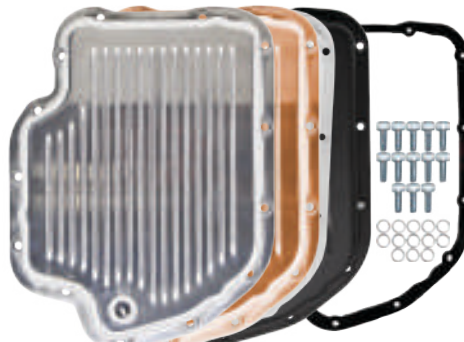

CHEVY/GM TURBO TH-400
HZ-8492-KIT-POL Polished
HZ-8492-KIT-PBK Black
HZ-8492-KIT-C Chrome
HZ-8492-KIT-COP Copper

DEPTH: 2-1/4"

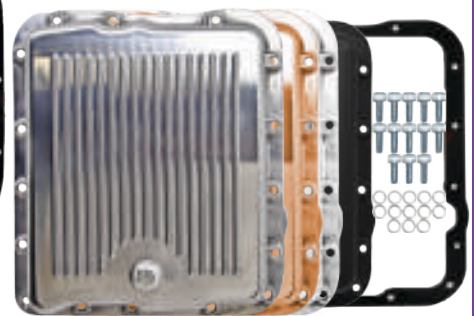

CHEVY/GM 700R4-4L60E-4L65E
HZ-8493-KIT-POL Polished
HZ-8493-KIT-PBK Black
HZ-8493-KIT-C Chrome
HZ-8493-KIT-COP Copper

DEPTH: 2-7/8"

STEEL TRANSMISSION PANS

NOTE: All transmission pans include drain plugs.



CHEVY/GM POWERGLIDE
HZ-9124-C Chrome
HZ-9124-PBK Black
HZ-9124-Z Zinc
DEPTH: 2"



CHEVY/GM TH-200
HZ-9123-C Chrome
HZ-9123-PBK Black
HZ-9123-Z Zinc
DEPTH: 2-5/8"



CHEVY/GM TH-350
HZ-9122-C Chrome **HZ-9198-C** Chrome
HZ-9122-PBK Black **HZ-9198-PBK** Black
HZ-9122-Z Zinc **HZ-9198-Z** Zinc
DEPTH: 2-1/4" **DEPTH: 3-1/2"**

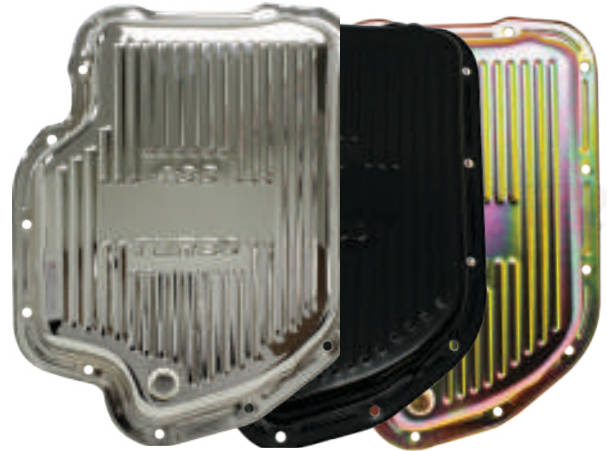

CHEVY/GM TH-400
HZ-9121-C Chrome **HZ-9197-C** Chrome
HZ-9121-PBK Black **HZ-9197-PBK** Black
HZ-9121-Z Zinc **HZ-9197-Z** Zinc
DEPTH: 2" **DEPTH: 3"**

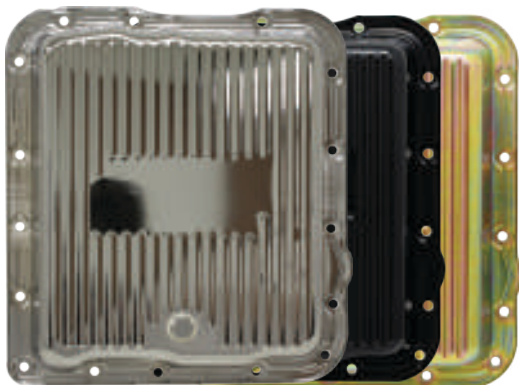

CHEVY/GM 700R4-4L60E-4L65E
HZ-7599-C Chrome **HZ-9712-C** Chrome
HZ-7599-PBK Black **HZ-9712-PBK** Black
HZ-7599-Z Zinc **HZ-9712-Z** Zinc
DEPTH: 2-5/8" **DEPTH: 3-5/8"**



MOPAR 727 TORQUE FLITE
HZ-9128-C Chrome **HZ-9129-C** Chrome
HZ-9128-PBK Black **HZ-9129-PBK** Black
DEPTH: 1-1/8" **DEPTH: 2-13/16"**

TRANSMISSION PANS

STEEL TRANSMISSION PANS



FORD C4

HZ-9531-C Chrome (Case Fill)

HZ-9531-PBK Black

HZ-9531-Z Zinc

HZ-9531-1-C Chrome (Pan Fill)

HZ-9531-1-PBK Black

HZ-9531-1-Z Zinc

DEPTH: 2-3/8"

HZ-9530-C Chrome (Case Fill)

HZ-9530-PBK Black

HZ-9530-Z Zinc

DEPTH: 4"



FORD C6

HZ-9125-C Chrome

HZ-9125-PBK Black

HZ-9125-Z Zinc

DEPTH: 2-3/8"



FORD AOD

HZ-9127-C Chrome

HZ-9127-PBK Black

DEPTH: 2-1/8"

TRANSMISSION PAN BOLTS & GASKETS

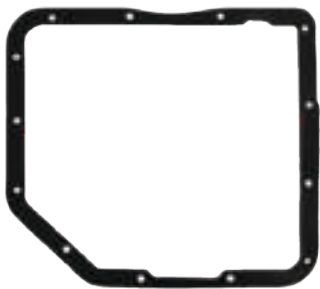

CHEVY/GM TH-350

HZ-8491-GKT

1 PIECE RUBBER

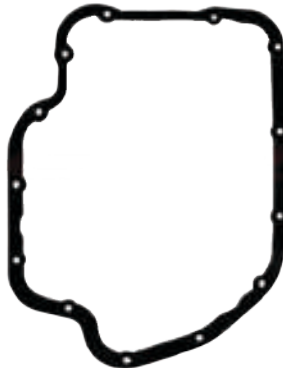

CHEVY/GM TH-400

HZ-8492-GKT

1 PIECE RUBBER

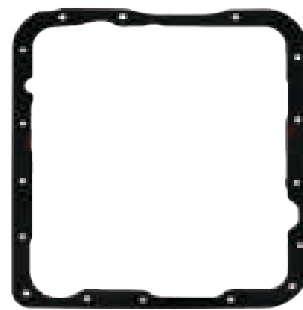

CHEVY/GM 700R4-4L60E-4L65E

HZ-8493-GKT

1 PIECE RUBBER

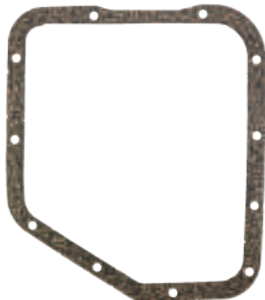

CHEVY/GM TH-200

HZ-200-GKT

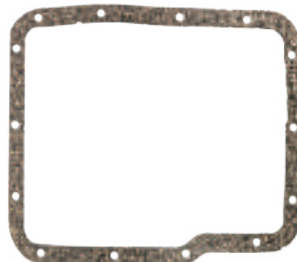

CHEVY/GM POWERGLIDE

HZ-PG-GKT

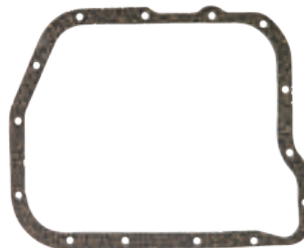

MOPAR 727

HZ-727-GKT



Chevy/GM TH-200
Allen Head Bolts

HZ-9133-C Chrome

HZ-9133-PBK Black

HZ-9133-SIL Silver

HZ-9133-Z Zinc

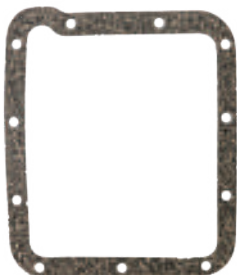

FORD C4

HZ-C4-GKT

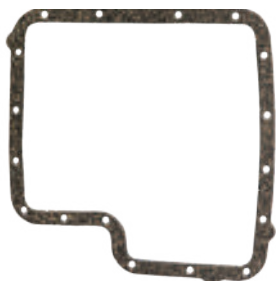

FORD C6

HZ-C6-GKT



Chevy/GM 700R4
Allen Head Bolts

HZ-8494-C Chrome

HZ-8494-PBK Black

HZ-8494-SIL Silver

HZ-8494-Z Zinc



Chevy/GM Turbo
TH-350/TH-400
Allen Head Bolts

HZ-8490-C Chrome

HZ-8490-PBK Black

HZ-8490-SIL Silver

HZ-8490-Z Zinc

CHEVY ENGINE OIL DIPSTICKS

Always compare length and markings with stock dipstick before installing

DIPSTICKS



**SMALL BLOCK CHEVY - DIPSTICK
1955-79**

HZ-4957-C Chrome
HZ-4957-PBK Black

LENGTH: 19"



**SMALL BLOCK CHEVY - DIPSTICK
1980-85**

HZ-9420-C Chrome
HZ-9420-PBK Black

LENGTH: 23"



**SMALL BLOCK CHEVY - FLEXIBLE DIPSTICK
1957-79 - BILLET HANDLE**

CFR-2002 Natural
CFR-2002-PBK Black

LENGTH: 20-1/8"



**SMALL BLOCK CHEVY - DIPSTICK
1955-79 - BILLET HANDLE**

HZ-4957D-C Chrome
HZ-4957D-PBK Black

LENGTH: 19"



**SMALL BLOCK CHEVY - DIPSTICK
1980-85 - BILLET HANDLE**

HZ-9420D-C Chrome
HZ-9420D-PBK Black

LENGTH: 23"



**SMALL BLOCK CHEVY - FLEXIBLE DIPSTICK
1980-UP - BILLET HANDLE**

CFR-2001 Natural
CFR-2001-PBK Black

LENGTH: 19-5/8"



**BIG BLOCK CHEVY - DIPSTICK
1965-90**

HZ-4958-C Chrome
HZ-4958-PBK Black

LENGTH: 21"



**BIG BLOCK CHEVY - DIPSTICK
1965-90 - BILLET HANDLE**

HZ-4958D-C Chrome
HZ-4958D-PBK Black

LENGTH: 21"



**BIG BLOCK CHEVY - FLEXIBLE DIPSTICK
1965-90 - BILLET HANDLE**

CFR-2000 Natural
CFR-2000-PBK Black

LENGTH: 21"



**CHEVY LS1 - FLEXIBLE DIPSTICK
1997-UP - BILLET HANDLE**

CFR-1999 Natural
CFR-1999-PBK Black

LENGTH: 17-1/8"



**SMALL BLOCK FORD - FLEXIBLE DIPSTICK
351W 5.8L 1969-85 - BILLET HANDLE**

CFR-1996 Natural
CFR-1996-PBK Black

LENGTH: 16-1/2"



**CHEVY LS - FLEXIBLE DIPSTICK
TRUCK - BILLET HANDLE**

CFR-1998 Natural
CFR-1998-PBK Black

LENGTH: 18-1/8"

Always compare length and markings with stock dipstick before installing



SMALL BLOCK FORD - DIPSTICK
260-289-302

HZ-9221-C Chrome
HZ-9221-PBK Black

LENGTH: 20-1/4"



SMALL BLOCK FORD - DIPSTICK
DRAG RACING (OIL PAN: 9450/9450-1)

HZ-9452E-C Chrome
HZ-9452E-PBK Black

LENGTH: 24-1/8"



SMALL BLOCK FORD - FLEXIBLE DIPSTICK
1962-69, 302 - **BILLET HANDLE**

CFR-1994 Natural
CFR-1994-PBK Black

LENGTH: 17-1/8"



PONTIAC - DIPSTICK
1965-79 V8
HZ-9405-C Chrome
HZ-9405-PBK Black

LENGTH: 17-1/21"

(Will Not Fit 389 or 403 Engines)



MOPAR SMALL BLOCK - DIPSTICK
BILLET HANDLE
HZ-9224-C Chrome
HZ-9224-PBK Black

LENGTH: 21"



MOPAR BIG BLOCK - DIPSTICK
BILLET HANDLE
HZ-9225-C Chrome
HZ-9225-PBK Black

LENGTH: 23"

ENGINE OIL DIPSTICKS



SMALL BLOCK FORD - DIPSTICK
260-289-302 - **BILLET HANDLE**

HZ-9221D-C Chrome
HZ-9221D-PBK Black

LENGTH: 20-1/4"



SMALL BLOCK FORD - DIPSTICK
351W - **BILLET HANDLE** (OIL PAN: 9755)

HZ-9220-C Chrome

LENGTH: 24-1/8"



SMALL BLOCK FORD - FLEXIBLE DIPSTICK
1986-95, 302 FOX BODY - **BILLET HANDLE**

CFR-1995 Natural
CFR-1995-PBK Black

LENGTH: 17-1/8"



PONTIAC - DIPSTICK
1965-79 V8 - **BILLET HANDLE**
HZ-9405D-C Chrome
HZ-9405D-PBK Black

LENGTH: 17-1/21"

(Will Not Fit 389 or 403 Engines)



MOPAR SMALL BLOCK - DIPSTICK
BILLET HANDLE

HZ-9224D-C Chrome
HZ-9224D-PBK Black

LENGTH: 21"



MOPAR SMALL BLOCK - DIPSTICK
BILLET HANDLE

HZ-9225D-C Chrome
HZ-9225D-PBK Black

LENGTH: 23"

TRANSMISSION DIPSTICKS

Always compare length and markings with stock dipstick before installing

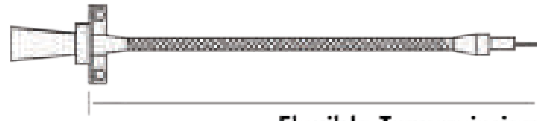

Dipstick Measurement Diagram

Flexible Transmission Dipsticks.

Fire Wall Mount Dipsticks.

CFR-3000 Ford AOD	39-1/4"
CFR-3000-PBK - Black	
CFR-3001 Ford C6	28-3/4"
CFR-3001-PBK - Black	
CFR-3002 Chevy/GM Powerglide	27"
CFR-3002-PBK - Black	
CFR-3003 Chevy/GM 700R4	28-7/8"
CFR-3003-PBK - Black	
CFR-3004 Chevy/GM TH-350/TH-400	27-3/16"
CFR-3004-PBK - Black	
CFR-3005 Chevy/GM 4L60E	27-5/8"
CFR-3005-PBK - Black	
CFR-3007 Mopar Torqueflite A-904	28"
CFR-3007-PBK - Black	
CFR-3009 Mopar 727	27-3/8"
CFR-3009-PBK - Black	

Trans Mount Dipsticks.

CFR-3101 Ford C6	13-3/4"
CFR-3101-PBK - Black	
CFR-3102 Chevy Powerglide	
CFR-3102-PBK - Black	
CFR-3103 Chevy Turbo TH-350	15-3/8"
CFR-3103-PBK - Black	
CFR-3104 Chevy Turbo TH-400	15-5/8"
CFR-3104-PBK - Black	
CFR-3105 Chevy Turbo 700R4	13-1/4"
CFR-3105-PBK - Black	

★ Features a stainless steel braided dipstick ★



CHEVY/GM TH350 - TRANSMISSION DIPSTICK (BELL HOUSING MOUNT)

HZ-4994-C Chrome
HZ-4994-PBK Black

LENGTH: 34"



CHEVY/GM TH350 - TRANSMISSION DIPSTICK BILLET HANDLE (BELL HOUSING MOUNT)

HZ-4994D-C Chrome
HZ-4994D-PBK Black

LENGTH: 34"



CHEVY/GM TH350 - TRANSMISSION DIPSTICK (BELL HOUSING MOUNT)

HZ-9421-C Chrome
HZ-9421-PBK Black

LENGTH: 27"



CHEVY/GM TH350 - TRANSMISSION DIPSTICK BILLET HANDLE (BELL HOUSING MOUNT)

HZ-9421D-C Chrome
HZ-9421D-PBK Black

LENGTH: 27"



CHEVY/GM TH400 - TRANSMISSION DIPSTICK (BELL HOUSING MOUNT)

HZ-4995-C Chrome
HZ-4995-PBK Black

LENGTH: 25"



CHEVY/GM TH400 - TRANSMISSION DIPSTICK BILLET HANDLE (BELL HOUSING MOUNT)

HZ-4995D-C Chrome
HZ-4995D-PBK Black

LENGTH: 25"



CHEVY/GM POWERGLIDE - TRANSMISSION DIPSTICK (BELL HOUSING MOUNT)

HZ-9422-C Chrome
HZ-9422-PBK Black

LENGTH: 23"



CHEVY/GM POWERGLIDE - TRANSMISSION DIPSTICK BILLET HANDLE (BELL HOUSING MOUNT)



HZ-9422D-C Chrome
HZ-9422D-PBK Black

LENGTH: 23"



Short water Pump (swp) fits 55-68-bolt circle is 1.75"
 Long Water Pump (lwp) fits 69-85-bolt circle is 2.30"

CHEVY BIG BLOCK STEEL PULLEYS

WATER PUMP PULLEYS





1955-68 SHORT (SWP)	1969-85 LONG (LWP)
DOUBLE GROOVE	DOUBLE GROOVE
	
<p>CHEVY BIG BLOCK - SWP WATER PUMP PULLEY - STEEL HZ-9815-C Chrome HZ-9815-PBK Black</p> <p>Diameter: 6-3/8" Depth: 2-3/4"</p>	<p>CHEVY BIG BLOCK - LWP WATER PUMP PULLEY - STEEL HZ-9723-C Chrome HZ-9723-PBK Black</p> <p>Diameter: 6- 1/8" Depth: 2-7/8"</p>

CRANKSHAFT PULLEYS

1955-68 SHORT (SWP)		1969-85 LONG (LWP)
SINGLE GROOVE	DOUBLE GROOVE	TRIPLE GROOVE
		
<p>CHEVY BIG BLOCK - SWP CRANKSHAFT PULLEY - STEEL HZ-9817-C Chrome HZ-9817-PBK Black</p> <p>Diameter: 6-11/16" Depth: 2-7/8" A/C Add-On Pulley Use w/ HZ-9816</p>	<p>CHEVY BIG BLOCK - SWP CRANKSHAFT PULLEY - STEEL HZ-9816-C Chrome HZ-9816-PBK Black</p> <p>Diameter: 7-3/4" Depth: 1-5/16"</p>	<p>CHEVY BIG BLOCK - LWP CRANKSHAFT PULLEY - STEEL HZ-9724-C Chrome HZ-9724-PBK Black</p> <p>Diameter: 7-3/4" Depth: 2-7/8"</p>

CHEVY SMALL BLOCK STEEL PULLEYS

WATER PUMP PULLEYS

1955-68 SHORT (SWP)		1969-85 LONG (LWP)	
SINGLE GROOVE	DOUBLE GROOVE	SINGLE GROOVE	DOUBLE GROOVE
			
<p>CHEVY SMALL BLOCK - SWP WATERPUMP PULLEY - STEEL HZ-9600-C Chrome HZ-9600-PBK Black</p> <p>Diameter: 6-3/16" Depth: 2-1/8"</p>	<p>CHEVY SMALL BLOCK - SWP WATERPUMP PULLEY - STEEL HZ-9601-C Chrome HZ-9601-PBK Black</p> <p>Diameter: 6-3/8" Depth: 2-13/16"</p>	<p>CHEVY SMALL BLOCK - LWP WATERPUMP PULLEY - STEEL HZ-9604-C Chrome HZ-9604-PBK Black</p> <p>Diameter: 7-1/8" Depth: 2-3/8"</p>	<p>CHEVY SMALL BLOCK - LWP WATERPUMP PULLEY - STEEL HZ-9605-C Chrome HZ-9605-PBK Black</p> <p>Diameter: 6-1/4" Depth: 2-3/4"</p>

CHEVY SMALL BLOCK STEEL PULLEYS

Short water Pump (swp) fits 55-68-bolt circle is 1.75"
Long Water Pump (lwp) fits 69-85-bolt circle is 2.30"

PULLEYS

CRANKSHAFT PULLEYS

1955-68 **SHORT (SWP)**

SINGLE GROOVE



**CHEVY SMALL BLOCK - SWP
CRANKSHAFT PULLEY - STEEL**
HZ-9817-C Chrome
HZ-9817-PBK Black

Diameter: 6-11/16" Depth: 2-7/8"
A/C Add-On Pulley Use w/ **HZ-9603**



**CHEVY SMALL BLOCK - SWP
CRANKSHAFT PULLEY - STEEL**
HZ-9602-C Chrome
HZ-9602-PBK Black

Diameter: 6-11/16" Depth: 11/16"

DOUBLE GROOVE



**CHEVY SMALL BLOCK - SWP
CRANKSHAFT PULLEY - STEEL**
HZ-9603-C Chrome
HZ-9603-PBK Black

Diameter: 7-3/16" Depth: 1-5/16"

TRIPLE GROOVE



**CHEVY SMALL BLOCK - SWP
CRANKSHAFT PULLEY - STEEL**
HZ-8963-C Chrome
HZ-8963-PBK Black

Diameter: 7-1/4" Depth: 2-1/16"

1969-85 **LONG (LWP)**

SINGLE GROOVE



**CHEVY SMALL BLOCK - LWP
CRANKSHAFT PULLEY - STEEL**
HZ-9606-C Chrome
HZ-9606-PBK Black

Diameter: 7-3/4" Depth: 2-3/4"

DOUBLE GROOVE



**CHEVY SMALL BLOCK - LWP
CRANKSHAFT PULLEY - STEEL**
HZ-9607-C Chrome
HZ-9607-PBK Black

Diameter: 6-7/8" Depth: 2-3/4"

TRIPLE GROOVE



**CHEVY SMALL BLOCK - LWP
CRANKSHAFT PULLEY - STEEL**
HZ-9608-C Chrome
HZ-9608-PBK Black

Diameter: 7-3/4" Depth: 2-5/8"

CHEVY BIG BLOCK ALUMINUM PULLEYS

WATER PUMP PULLEYS

1955-68 **SHORT (SWP)**

SINGLE GROOVE



**CHEVY BIG BLOCK - SWP
WATER PUMP PULLEY - ALUMINUM**
HZ-8840-C Chrome
HZ-8840-POL Polished
HZ-8840-PBK Black
HZ-8840-M Machined

Diameter: 6-7/16" Depth: 2-3/4"

DOUBLE GROOVE



**CHEVY BIG BLOCK - SWP
WATER PUMP PULLEY - ALUMINUM**
HZ-8842-C Chrome
HZ-8842-POL Polished
HZ-8842-PBK Black
HZ-8842-M Machined

Diameter: 6-9/16" Depth: 2-7/8"

1969-85 **LONG (LWP)**

DOUBLE GROOVE







**CHEVY BIG BLOCK - SWP
WATER PUMP PULLEY - ALUMINUM**
HZ-8844-C Chrome
HZ-8844-POL Polished
HZ-8844-PBK Black
HZ-8844-M Machined

Diameter: 6-1/4" Depth: 2-3/4"





CHEVY BIG BLOCK ALUMINUM PULLEYS

CRANKSHAFT PULLEYS



1955-68 SHORT (SWP)		1969-85 LONG (LWP)	
SINGLE GROOVE	DOUBLE GROOVE	TRIPLE GROOVE	TRIPLE GROOVE
			
CHEVY BIG BLOCK - SWP CRANKSHAFT PULLEY - ALUMINUM HZ-8841-C Chrome HZ-8841-POL Polished HZ-8841-PBK Black HZ-8841-M Machined	CHEVY BIG BLOCK - SWP CRANKSHAFT PULLEY - ALUMINUM HZ-8843-C Chrome HZ-8843-POL Polished HZ-8843-PBK Black HZ-8843-M Machined	CHEVY BIG BLOCK - SWP CRANKSHAFT PULLEY - ALUMINUM HZ-8849-C Chrome HZ-8849-POL Polished HZ-8849-PBK Black HZ-8849-M Machined	CHEVY BIG BLOCK - LWP CRANKSHAFT PULLEY - ALUMINUM HZ-8845-C Chrome HZ-8845-POL Polished HZ-8845-PBK Black HZ-8845-M Machined
Diameter: 6-3/8" Depth: 3/4"	Diameter: 6-3/8" Depth: 1-3/8"	Diameter: 6-3/8" Depth: 2"	Diameter: 7-3/4" Depth: 3"

CHEVY SMALL BLOCK ALUMINUM PULLEYS

WATER PUMP PULLEYS

1955-68 SHORT (SWP)		1969-85 LONG (LWP)	
SINGLE GROOVE	DOUBLE GROOVE	SINGLE GROOVE	DOUBLE GROOVE
			
CHEVY SMALL BLOCK - SWP WATER PUMP PULLEY - ALUMINUM HZ-9478-C Chrome HZ-9478-POL Polished HZ-9478-PBK Black HZ-9478-M Machined	CHEVY SMALL BLOCK - SWP WATER PUMP PULLEY - ALUMINUM HZ-9479-C Chrome HZ-9479-POL Polished HZ-9479-PBK Black HZ-9479-M Machined	CHEVY SMALL BLOCK - LWP WATER PUMP PULLEY - ALUMINUM HZ-9482-C Chrome HZ-9482-POL Polished HZ-9482-PBK Black HZ-9482-M Machined	CHEVY SMALL BLOCK - LWP WATER PUMP PULLEY - ALUMINUM HZ-9483-C Chrome HZ-9483-POL Polished HZ-9483-PBK Black HZ-9483-M Machined
Diameter: 6-9/16" Depth: 3"	Diameter: 6-9/16" Depth: 2-7/8"	Diameter: 6-9/16" Depth: 2-1/4"	Diameter: 6-9/16" Depth: 2-7/8"

CRANKSHAFT PULLEYS

1955-68 SHORT (SWP)		
SINGLE GROOVE	DOUBLE GROOVE	TRIPLE GROOVE
		
CHEVY SMALL BLOCK - SWP CRANKSHAFT PULLEY - ALUMINUM HZ-9480-C Chrome HZ-9480-POL Polished HZ-9480-PBK Black HZ-9480-M Machined	CHEVY SMALL BLOCK - SWP CRANKSHAFT PULLEY - ALUMINUM HZ-9481-C Chrome HZ-9481-POL Polished HZ-9481-PBK Black HZ-9481-M Machined	CHEVY SMALL BLOCK - SWP CRANKSHAFT PULLEY - ALUMINUM HZ-8858-C Chrome HZ-8858-POL Polished HZ-8858-PBK Black HZ-8858-M Machined
Diameter: 6-9/16"	Diameter: 6-5/8"	Diameter: 6-7/16" Depth: 1-15/16"

CHEVY SMALL BLOCK ALUMINUM PULLEYS

CRANKSHAFT PULLEYS

1969-85 **LONG (LWP)**

SINGLE GROOVE



**CHEVY SMALL BLOCK - LWP
CRANKSHAFT PULLEY - ALUMINUM**

- HZ-9484-C** Chrome
- HZ-9484-POL** Polished
- HZ-9484-PBK** Black
- HZ-9484-M** Machined

Diameter: 6-9/16" Depth: 2-3/4"

DOUBLE GROOVE



**CHEVY SMALL BLOCK - LWP
CRANKSHAFT PULLEY - ALUMINUM**

- HZ-9485-C** Chrome
- HZ-9485-POL** Polished
- HZ-9485-PBK** Black
- HZ-9485-M** Machined

Diameter: 6-9/16" Depth: 2-11/16"

TRIPLE GROOVE



**CHEVY SMALL BLOCK - LWP
CRANKSHAFT PULLEY - ALUMINUM**

- HZ-9486-C** Chrome
- HZ-9486-POL** Polished
- HZ-9486-PBK** Black
- HZ-9486-M** Machined

Diameter: 6-9/16" Depth: 2-3/4"

CHEVY ALUMINUM SERPENTINE PULLEY SET

6 groove CNC machined billet aluminum. Fits 283-400 engines.
(Requires reverse rotation water pump)



**6 GROOVE ALUMINUM
SERPENTINE PULLEY SET-SWP**

- HZ-8700-POL** Polished
- HZ-8700-M** Machined

Diameters -
Crank: 6-7/8"
Alternator: 4-3/8"
Water Pump: 5-5/8"
*Power Steering: 5-3/4"
*(Key Way)



**6 GROOVE ALUMINUM
SERPENTINE PULLEY SET-LWP**

- HZ-8701-POL** Polished
- HZ-8701-M** Machined

Diameters -
Crank: 6-7/8"
Alternator: 4-3/8"
Water Pump: 5-5/8"
*Power Steering: 5-3/4"
*(Key Way)



**1988-92 CHEVY CAMARO/
PONTIAC FIREBIRD 305/350 V8**

HZ-04400-POL Polished

Crank Dia. 6-7/8" **Alternator Dia.** 1-7/8"



**1994-96 GM TRUCK
7.4L 454 V8**

HZ-05061-POL Polished

Crank Dia. 5-7/8" **Alternator Dia.** 3"

FORD SMALL BLOCK 289 STEEL PULLEYS

FORD SMALL BLOCK STEEL WATER PUMP PULLEYS 1964-73 (For California Smog Pump)

SINGLE GROOVE



FORD SMALL BLOCK 1965-66 WATER PUMP PULLEY - STEEL
HZ-9770-C Chrome
HZ-9770-PBK Black

Diameter: 6.125"

DOUBLE GROOVE



FORD SMALL BLOCK 1965-66 WATER PUMP PULLEY - STEEL
HZ-9775-C Chrome
HZ-9775-PBK Black

Diameter: 5.875"

TRIPLE GROOVE



FORD SMALL BLOCK 1964-73 WATER PUMP PULLEY - STEEL
HZ-9773-C Chrome
HZ-9773-PBK Black

Diameter: 5.897"

FORD SMALL BLOCK STEEL CRANKSHAFT PULLEYS 1964-66

SINGLE GROOVE



FORD SMALL BLOCK 1965-66 CRANKSHAFT PULLEY - STEEL
HZ-9771-C Chrome
HZ-9771-PBK Black

Diameter: 6.312"

DOUBLE GROOVE



FORD SMALL BLOCK 1964-66 CRANKSHAFT PULLEY - STEEL
HZ-9774-C Chrome
HZ-9774-PBK Black

Diameter: 6.687"

TRIPLE GROOVE



FORD SMALL BLOCK 1965-66 CRANKSHAFT PULLEY - STEEL
HZ-9772-C Chrome
HZ-9772-PBK Black

Diameter: 6.750"

PULLEY MOUNTING BOLTS

HZ-7756

Pcs 4

Water Pump Pulley
 Nose Bolt Set

5/16"-24 x 3/4" Flat Head Cap Screw



HZ-9912

Pcs 4

Water Pump Pulley
 Bolt Set

5/16"-24 x 3/4" Flat Head Socket



HZ-9924

Pcs 3

Crank Pulley/ Lower
 Pulley Bolt Set

3/8"-24 x 1"



HZ-9925

Pcs 3

Crank Pulley/ Lower
 Pulley Bolt Set

7/16"-20 x 1"



WATER PUMP IDENTIFICATION

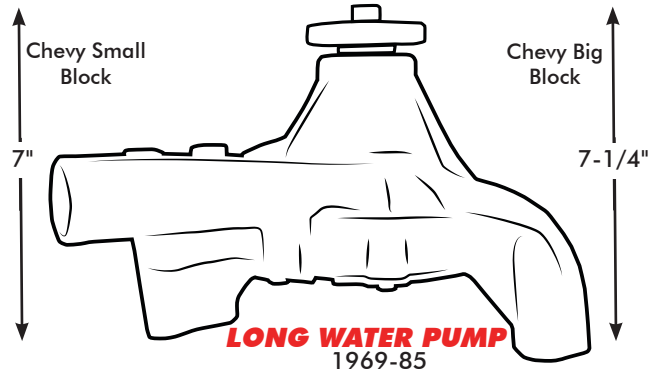
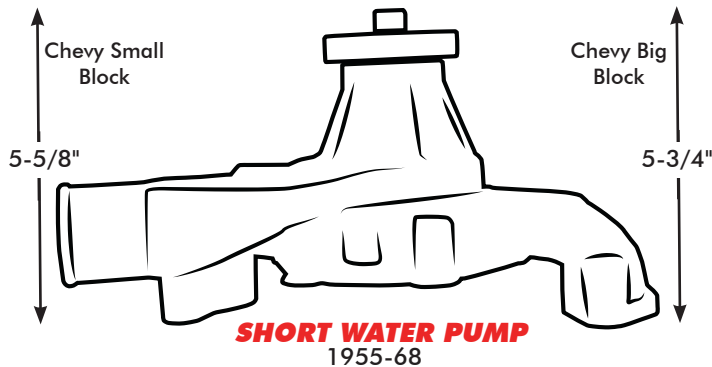

CHEVY SMALL BLOCK ALUMINUM LWP KITS



Part #	Kit Includes:	Pump	Finish
HZ-9485-C-KIT	Pulleys: Single Groove Power Steering(HZ-8848), Double Groove Water Pump(HZ-9483) W/ Nose(HZ-9489), Double Groove Crank(HZ-9485), Single Groove Alternator W/Fan & Nose (HZ-8867 , HZ-9487), Mounting Bolts	LWP	Chrome
HZ-9485-M-KIT			Machined
HZ-9485-POL-KIT			Polished
Pulley's Only			



Part #	Kit Includes:	Pump	Finish
HZ-4304-C-KIT	Pulleys: Single Groove Power Steering(HZ-8848), Double Groove Water Pump(HZ-9483) W/ Nose(HZ-9489), Double Groove Crank(HZ-9485), Single Groove Alternator W/Fan & Nose (HZ-8867 , HZ-9487), Mounting Bolts	LWP	Chrome
HZ-4304-M-KIT			Machined
HZ-4304-POL-KIT			Polished
Pulley's and Brackets			

CHEVY SMALL BLOCK ALUMINUM SWP KITS



Part #	Kit Includes:	Pump	Finish
HZ-9481-C-KIT	Pulleys: Single Groove Power Steering(HZ-8848), Double Groove Water Pump(HZ-9479) W/ Nose(HZ-9488), Double Groove Crank(HZ-9481), Single Groove Alternator W/Fan & Nose (HZ-8867 , HZ-9487), Mounting Bolts	SWP	Chrome
HZ-9481-M-KIT			Machined
HZ-9481-POL-KIT			Polished
Pulley's Only			



Part #	Kit Includes:	Pump	Finish
HZ-6407-C-KIT	Pulleys: Single Groove Power Steering(HZ-8848), Double Groove Water Pump(HZ-9479) W/ Nose(HZ-9488), Double Groove Crank(HZ-9481), Single Groove Alternator W/Fan & Nose (HZ-8867 , HZ-9487), Mounting Bolts	SWP	Chrome
HZ-6407-M-KIT			Machined
HZ-6407-POL-KIT			Polished
Pulley's and Brackets			

POWER STEERING PULLEYS



CHEVY/GM 1967-84 V-BELT SINGLE GROOVE - KEY WAY - STEEL
HZ-8948-C Chrome
HZ-8948-PBK Black

Diameter: 5-3/4"



CHEVY/GM 1967-84 V-BELT DOUBLE GROOVE - KEY WAY - STEEL
HZ-8949-C Chrome
HZ-8949-PBK Black

Diameter: 5-3/4"



CHEVY/GM/FORD V-BELT TYPE II SINGLE GROOVE - PRESS FIT ALUMINUM
HZ-8851-C Chrome
HZ-8851-PBK Black
HZ-8851-POL Polished

Diameter: 4-5/16"



CHEVY/GM 1967-84 V-BELT SINGLE GROOVE - KEY WAY ALUMINUM
HZ-8848-C Chrome
HZ-8848-PBK Black
HZ-8848-POL Polished
HZ-8848-M Machined

Diameter: 5-3/4"



CHEVY/GM 1967-84 V-BELT DOUBLE GROOVE - KEY WAY ALUMINUM
HZ-8846-C Chrome
HZ-8846-PBK Black
HZ-8846-POL Polished
HZ-8846-M Machined

Diameter: 5-3/4"



CHEVY/GM/FORD SERPENTINE TYPE II SINGLE GROOVE - PRESS FIT ALUMINUM
HZ-8852-C Chrome
HZ-8852-PBK Black
HZ-8852-POL Polished

Diameter: 4-5/16"

PULLEY NOSE & BOLTS



CHEVY SMALL BLOCK -SWP 1955-68 WATER PUMP NOSE KIT

HZ-9488-C Chrome
HZ-9488-PBK Black
HZ-9488-POL Polished
HZ-9488-M Machined

Diameter: 3"



CHEVY SMALL BLOCK -LWP 1969-85 WATER PUMP NOSE KIT

HZ-9489-C Chrome
HZ-9489-PBK Black
HZ-9489-POL Polished
HZ-9489-M Machined

Diameter: 3"



CHEVY SMALL BLOCK -A/C CLUTCH COVER SANDEN 508 KIT

HZ-8850-C Chrome
HZ-8850-PBK Black
HZ-8850-POL Polished
HZ-8850-M Machined

Diameter: 5"



ALTERNATOR NOSE KIT ALUMINUM

HZ-9487-C Chrome
HZ-9487-PBK Black
HZ-9487-POL Polished
HZ-9487-M Machined

Diameter: 2-7/8"



ALTERNATOR FAN ALUMINUM

HZ-8867-C Chrome
HZ-8867-PBK Black
HZ-8867-POL Polished
HZ-8867-M Machined

Diameter: 2-7/8"



WATER PUMP PULLEY NOSE BOLT SET

HZ-7756-C Chrome
 (5/16-24 x 3/4" Hex Head Cap Screw)

FORD MUSTANG PULLEYS



**FORD MUSTANG 5.0L 1979-93
SERPENTINE PULLEY KIT - ALUMINUM**

HZ-02010-C Chrome **HZ-02010-PBK** Black
HZ-02010-PBL Blue **HZ-02010-POL** Polished
HZ-02010-M Machined

Underdrive pulley sets come with 6-groove alternator, crank and water pump pulley.

FORD MUSTANG POWER STEERING PULLEYS



**FORD MUSTANG 5.0L 1979-93
POWER STEERING PULLEY - ALUMINUM**

HZ-02011-C Chrome **HZ-02011-PBK** Black
HZ-02011-PBL Blue **HZ-02011-POL** Polished
HZ-02011-M Machined

6-groove billet aluminum power steering pump pulleys.

One Time Use Only

FORD MUSTANG LATE MODEL PULLEYS



**FORD MUSTANG GT LATE MODEL
1999-00 4.6L PULLEY KIT - ALUMINUM**

HZ-02255-POL Polished
HZ-02255-M Machined

**COMES WITH: ALTERNATOR,
CRANK ,WATER PUMP PULEY**

**FORD MUSTANG GT/ COBRA LATE MODEL
1996-98 4.6L PULLEY KIT - ALUMINUM**

HZ-02250-POL Polished
HZ-02250-M Machined

**COMES WITH: ALTERNATOR,
CRANK ,WATER PUMP PULEY**

STEEL ALTERNATOR BRACKETS

BRACKETS

CHEVY BIG BLOCK - SHORT WATER PUMP



**CHEVY BIG BLOCK - SWP
LOWER ALTERNATOR BRACKET**
1969-UP 396-402-427-454
HZ-9502-C Chrome
HZ-9502-PBK Black



**CHEVY BIG BLOCK - SWP
LOWER ALTERNATOR BRACKET**
1955-68 396-402-427-454
HZ-9758-C Chrome

CHEVY BIG BLOCK - LONG WATER PUMP



**CHEVY BIG BLOCK - LWP
ALTERNATOR BRACKET - OEM STYLE**
1969-UP 396-402-427-454
HZ-9318-C Chrome
TOP



**CHEVY BIG/SMALL BLOCK - LWP
UPPER ALTERNATOR BRACKET**
1969-75 305-327-350-400/
396-402-427-454
HZ-9320-C Chrome

CHEVY SMALL BLOCK - SHORT WATER PUMP



**CHEVY SMALL BLOCK - SWP
LOW MOUNT ALTERNATOR BRACKET**
1955-68 283-305-327-350
HZ-7758-C Chrome
Includes mounting hardware



**CHEVY SMALL BLOCK - SWP
WATER PUMP MOUNTED
ALTERNATOR BRACKET - OEM STYLE**
1965-68 283-305-327-350
HZ-9315-C Chrome



**CHEVY SMALL BLOCK - SWP
LOWER ALTERNATOR BRACKET**
1955-68 283-305-327-350
HZ-9758-C Chrome



**CHEVY SMALL BLOCK - SWP
UPPER ALTERNATOR BRACKET
UNIVERSAL**
HZ-9079-C Chrome



**CHEVY SMALL BLOCK - SWP
UPPER ALTERNATOR BRACKET
UNIVERSAL**
HZ-9325-C Chrome
HZ-9325-PBK Black

STEEL ALTERNATOR BRACKETS

CHEVY SMALL BLOCK - LONG WATER PUMP



**CHEVY SMALL BLOCK - LWP
WATER PUMP MOUNTED BRACKET
OEM STYLE**
1969-75 305-327-350-400
HZ-9316-C Chrome
HZ-9316-PBK Black



**CHEVY SMALL BLOCK - LWP
WATER PUMP MOUNTED BRACKET
OEM STYLE**
1969-86 305-327-350-400
HZ-9317-C Chrome
HZ-9317-PBK Black



**CHEVY SMALL BLOCK - LWP
LOWER ALTERNATOR BRACKET**
1969-86 305-327-350-400
HZ-9637-C Chrome



**CHEVY SMALL/BIG BLOCK - LWP
UPPER ALTERNATOR BRACKET**
1969-75
305-327-350-396-402-400-427-454
HZ-9320-C Chrome



**CHEVY SMALL BLOCK - LWP
UPPER ALTERNATOR BRACKET**
1979-86 305-327-350-400
HZ-9321-C Chrome



FORD SMALL BLOCK

**FORD SMALL BLOCK
ALTERNATOR BRACKET
OEM STYLE**
1965-69 289-302
HZ-9455-C Chrome
HZ-9455-PBK Black

STEEL HEADER BRACKETS

1955-68 Universal header slide bracket and base. Bracket base attaches at #1 Cylinder exhaust port for tubular headers.



**CHEVY SMALL BLOCK - SWP
ALTERNATOR BRACKET
F STYLE**
1955-68 289-302
HZ-9322-C Chrome
HZ-9322-PBK Black
Base

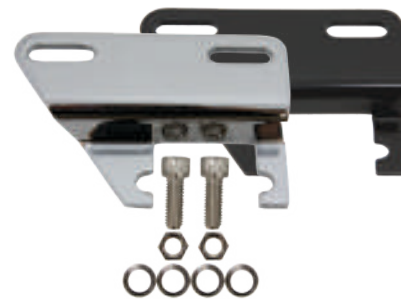

**CHEVY SMALL BLOCK - SWP
ALTERNATOR BRACKET
F STYLE**
1955-68 289-302
HZ-9323-C Chrome
HZ-9323-PBK Black
Slide
Driver Side Only

ALUMINUM ALTERNATOR BRACKETS



**CHEVY BIG BLOCK - SWP
LOWER ALTERNATOR BRACKET**
396-402-427-454-502
HZ-6421-C Chrome
HZ-6421-POL Polished
DRIVER SIDE MOUNT



**CHEVY BIG BLOCK - LWP
LOWER ALTERNATOR BRACKET**
396-402-427-454-502
HZ-6423-C Chrome
HZ-6423-POL Polished
PASSENGER SIDE MOUNT

CHEVY SMALL BLOCK - SHORT WATER PUMP



**CHEVY SMALL BLOCK - SWP
ALTERNATOR BRACKET**
262-267-283-302-305-307-327-350-400
HZ-6425-C Chrome
HZ-6425-POL Polished
DRIVER SIDE MOUNT

CHEVY SMALL BLOCK - LONG WATER PUMP



**CHEVY SMALL BLOCK - LWP
ALTERNATOR BRACKET**
283-305-327-350-400
HZ-4324-C Chrome
HZ-4324-POL Polished
PASSENGER SIDE MOUNT

FORD SMALL BLOCK



**FORD 5.0L MUSTANG
ALTERNATOR BRACKET**
1979 -93
HZ-4320-C Chrome
HZ-4320-POL Polished
DRIVER SIDE MOUNT

POWER STEERING BRACKETS

CHEVY SMALL BLOCK- LONG/ SHORT WATER PUMP



Small Block Chevy Short water Pump & Long Water Pump Chrome Steel Saginaw Power Steering Bracket Set Complete with mounting hardware

CHEVY SMALL/BIG BLOCK ADJUSTABLE POWER STEERING BRACKET- STEEL

HZ-9200-C Chrome
HZ-9200-PBK Black
DRIVER SIDE MOUNT

CHEVY SMALL BLOCK - LONG WATER PUMP

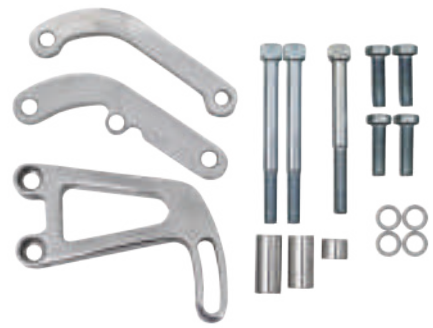

CHEVY SMALL/BIG BLOCK - LWP POWER STEERING BRACKET - ALUMINUM
1963-87 283-305-327-350-400

HZ-4322-C Chrome
HZ-4322-POL Polished
DRIVER SIDE MOUNT

FORD SMALL BLOCK



FORD 5.0L MUSTANG POWER STEERING BRACKET - ALUMINUM
1979-93 5.0L

HZ-4326-C Chrome
HZ-4326-POL Polished
HZ-4326-PBK Black
HZ-4326-PBL Blue
DRIVER SIDE MOUNT

AIR CONDITIONING BRACKETS

BRACKETS

CHEVY SMALL/ BIG BLOCK- LONG/ SHORT WATER PUMP

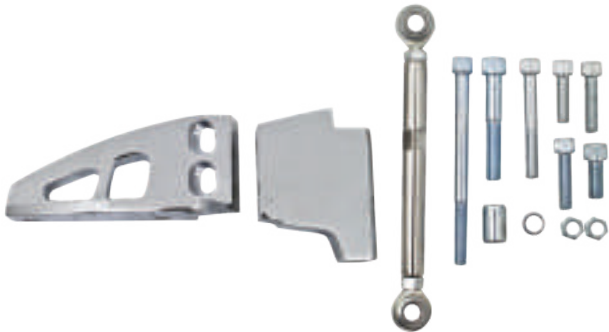

**CHEVY SMALL BLOCK - SWP
AIR CONDITIONING BRACKET - ALUMINUM**
262-267-283-305-327-350-400

HZ-6426-C Chrome
HZ-6426-POL Polished
DRIVER SIDE MOUNT



**CHEVY BIG BLOCK - SWP
AIR CONDITIONING BRACKET - ALUMINUM**

HZ-6422-C Chrome
HZ-6422-POL Polished
PASSENGER SIDE MOUNT



**CHEVY SMALL BLOCK - SWP/LWP ADJUSTABLE
AIR CONDITIONING BRACKET - STEEL**
262-267-283-305-327-350-400



HZ-9324-C-KIT Chrome
HZ-9324-PBK-KIT Black
DRIVER SIDE MOUNT

ADJUSTABLE TENSION RODS

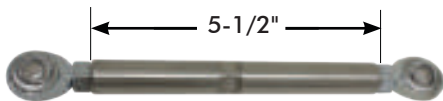

HZ-4307 Natural
HZ-4307-POL Polished
5-1/2" Stainless steel rod.
Diameter: 5/8"

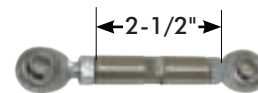

HZ-4308 Natural
HZ-4308-POL Polished
2-1/2" Stainless steel rod.
Diameter: 5/8"



HZ-4309 Natural
HZ-4309-POL Polished
7" Stainless steel rod. Diameter: 5/8"

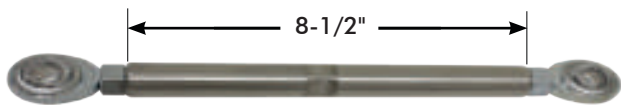

HZ-4310 Natural
HZ-4310-POL Polished
8-1/2" Stainless steel rod. Diameter: 5/8"

EMC RADIATORS



This is the most extreme modular system available for any application. Our engineers have conducted extensive research to determine this is the optimum combination of size and volume for maximum cooling efficiency in extreme applications. These advanced cooling modules also include 7 separate 3/8-24" threaded bungs for attaching optional mounting bracket kits and hardware allowing the unique option of using this radiator as a traditional top and bottom tank design or the modern cross-flow design.



7-3/8-24" Threaded Bungs



15 Fins per inch



850 HP Rated

Part #	Size
HZ-40010-X2	22" x 19"
HZ-40011-X2	24" x 19"
HZ-40012-X2	26" x 19"
HZ-40016-X2	31" x 19"



1250 HP Rated

Part #	Size
HZ-40010-X3	22" x 19"
HZ-40011-X3	24" x 19"
HZ-40012-X3	26" x 19"
HZ-40016-X3	31" x 19"

The EMC=X2 has an oversized 2 1/4" thick cooling core with two rows of 1" high volume and high flow heat transfer tubes with an optimized 15 fins per inch of cooling power.

The EMC=X3 has a huge 3 1/2" thick cooling core with three rows of 7/8" high volume and high flow heat transfer tubes with an optimized 15 fins per inch of cooling power

7 separate AN-20 bungs allowing the ultimate in universal configuration. We have adapter fittings for the AN-20 bungs to allow the following attachments:



Part #	Description
HZ-40030-KIT	20AN Male to 1.25" Radiator Hose Fitting
HZ-40031-KIT	20AN Male to 1.75" Radiator Hose Fitting
HZ-40032-KIT	20AN Male to 1.50" Radiator Hose Fitting
HZ-40033-KIT	20AN Male to -16AN Male Coupling
HZ-40034-KIT	20AN Male to -20AN Male Coupling
HZ-40035-KIT	20AN Male to 1/2" NPT Adapter
HZ-40036-KIT	20AN Male to 3/8" NPT Adapter
HZ-40037-KIT	20AN Male Plug
HZ-40038-KIT	20AN male to 2 1/8" Filler Neck
HZ-40040-KIT	Radiator Overflow Fitting
HZ-40041-KIT	20AN O-Ring
HZ-40045-KIT	Aluminum Angled Mounting Bracket
HZ-40046-KIT	Aluminum Flat Mounting Bracket

ALUMINIUM RADIATORS

Direct Fit Aluminum Radiators Features. All of CFR Performance's direct fit aluminum radiators include: mounting brackets that position the radiator in the stock location, 2-row furnace brazed core with 1" tubes, machined billet filler water neck with overflow fitting, and furnace brazed tanks, and epoxy free construction.

1959-72 Chevy Impala Direct Fit Aluminum Radiators.

These radiators also fit for 1964-67 Chevy Chevelle.

- HZ-5972** Natural
- *HZ-5972-AT** Natural
- HZ-5972-PBK** Black
- *HZ-5972-AT-PBK** Black
- HZ-5972-LS** Natural for LS

- HZ-5972-POL** Polished
- *HZ-5972-AT-POL** Polished
- HZ-5972-LS-POL** Polished for LS



Overall Size: 28-5/8"W x 19-1/2"H x 3"D

Core Size: 20-3/4"W x 18-1/4"H x 2-1/4"D

*** Features Built-in Automatic Transmission Cooler.**

1967-69 Chevy Camaro Direct Fit Aluminum Radiator.

Features a built-in Temperature Sensor Bung.

- HZ-6769** Natural
- *HZ-6769-AT** Natural
- HZ-6769-PBK** Black
- *HZ-6769-AT-PBK** Black
- HZ-6769-LS** Natural for LS

- HZ-6769-POL** Polished
- *HZ-6769-AT-POL** Polished
- HZ-6769-LS-POL** Polished for LS



Overall Size: 28-1/4"W x 19-1/2"H x 3-1/4"D

Core Size: 25-3/4"W x 18-1/2"H x 2-1/4"D

*** Features Built-in Automatic Transmission Cooler.**

1970-81 Chevy Camaro/Chevelle/Nova Direct Fit Aluminum Radiators.

Features a built-in Temperature Sensor Bung.

- HZ-7081** Natural
- *HZ-7081-AT** Natural
- HZ-7081-PBK** Black
- *HZ-7081-AT-PBK** Black
- HZ-7081-LS** Natural for LS

- HZ-7081-POL** Polished
- *HZ-7081-AT-POL** Polished
- HZ-7081-LS-POL** Polished for LS



Overall Size: 31.25"W x 19.5"H x 3"D

Core Size: 26"W x 17.75"H x 2.25"D

Features Built-in Automatic Transmission Cooler.

**** Uses Dual Pass Cooling System.**

1979-93 Ford 5.0L 302 Direct Fit Aluminum Radiator.

- HZ-79MU-ML** Natural
- *HZ-79MU-AT** Natural
- HZ-79MU-ML-PBK** Black
- *HZ-79MU-AT-PBK** Black

- HZ-79MU-ML-POL** Polished
- *HZ-79MU-AT-POL** Polished



Overall Size: 28-7/8"W x 19"H x 3-1/8"D

Core Size: 24-3/8"W x 18-5/8"H x 2-1/4"D

*** Features Built-in Automatic Transmission Cooler.**



1957 Chevy Straight/Inline 6 Cylinder Direct Fit Aluminum Radiator.

Designed for Chevy passenger cars with engines running a short or long style water pump. Features a built-in automatic transmission cooler, temperature sensor bung, and drain petcock with mounting clips.

- HZ-5700-6** Natural
- HZ-5700-6-POL** Polished
- HZ-5700-6-PBK** Black

Overall Size: 23-1/8"W x 23-1/4"H x 3"D
Core Size: 21-7/8"W x 17-1/4"H x 2-1/2"D



1955-56 Chevy V6 Cylinder Direct Fit Aluminum Radiator.

Features a built-in automatic transmission cooler, temperature sensor bung, and drain petcock with mounting clips.

- HZ-5556-6** Natural
- HZ-5556-6-POL** Polished
- HZ-5556-6-PBK** Black

Overall Size: 23-1/8"W x 23"H x 3-3/4"D
Core Size: 21-3/4"W x 16-1/2"H x 2-1/2"D



1955-57 Chevy V8 Direct Fit Aluminum Radiator.

Designed for engines running a short style water pump. Features a built-in automatic transmission cooler, temperature sensor bung, and drain petcock with mounting clips.

- HZ-5557-8** Natural
- HZ-5557-8-POL** Polished
- HZ-5557-8-PBK** Black

Overall Size: 23-1/4"W x 23"H x 3"D
Core Size: 21-3/4"W x 16-1/2"H x 2-1/2"D

ALUMINUM RADIATOR KITS

Direct Fit Aluminum Radiators Features. All of CFR Performance's direct fit aluminum radiators include: mounting brackets that position the radiator in the stock location, 2-row furnace brazed core with 1" tubes, machined billet filler water neck with overflow fitting, and furnace brazed tanks, and epoxy free construction.

1959-72 Chevy Impala Direct Fit Aluminum Radiators. These radiators also fit for 1964-67 Chevy Chevelle.

- HZ-5972-KIT** Natural
- *HZ-5972-AT-KIT** Natural

- HZ-5972-POL-KIT** Polished
- *HZ-5972-AT-POL-KIT** Polished

Overall Size: 28-5/8"W x 19-1/2"H x 3"D
Core Size: 20-3/4"W x 18-1/4"H x 2-1/4"D
 * Features Built-in Automatic Transmission Cooler.



1967-69 Chevy Camaro Direct Fit Aluminum Radiator. Features a built-in Temperature Sensor Bung. Small Block Chevy

- HZ-6769-KIT** Natural
- *HZ-6769-AT-KIT** Natural

- HZ-6769POL-KIT** Polished
- *HZ-6769-AT-POL-KIT** Polished

Overall Size: 28-1/4"W x 19-1/2"H x 3-1/4"D
Core Size: 25-3/4"W x 18-1/2"H x 2-1/4"D
 * Features Built-in Automatic Transmission Cooler.



1970-81 Chevy Camaro/Chevelle/Nova Direct Fit Aluminum Radiators. Features a built-in Temperature Sensor Bung.

- HZ-7081-KIT** Natural
 - *HZ-7081-AT-KIT** Natural

 - HZ-7081-POL-KIT** Polished
 - *HZ-7081-AT-POL-KIT** Polished
- Overall Size:** 31.25"W x 19.5"H x 3"D
Core Size: 26"W x 17.75"H x 2.25"D
 * Features Built-in Automatic Transmission Cooler.



1979-93 Ford 5.0L 302 Direct Fit Aluminum Radiator.

- HZ-79MU-ML-KIT** Natural
 - *HZ-79MU-AT-KIT** Natural

 - HZ-79MU-ML-POL-KIT** Polished
 - *HZ-79MU-AT-POL-KIT** Polished
- Overall Size:** 28-7/8"W x 19"H x 3-1/8"D
Core Size: 24-3/8"W x 18-5/8"H x 2-1/4"D
 * Features Built-in Automatic Transmission Cooler.



1957 Chevy Straight/Inline 6 Cylinder Direct Fit Aluminum Radiator. Designed for Chevy passenger cars with engines running a short or long style water pump. Features a built-in automatic transmission cooler, temperature sensor bung, and drain petcock with mounting clips.

- HZ-5700-6-KIT** Natural
 - HZ-5700-6-POL-KIT** Polished
- Overall Size:** 23-1/8"W x 23-1/4"H x 3"D
Core Size: 21-7/8"W x 17-1/4"H x 2-1/2"D



1955-56 Chevy V6 Cylinder Direct Fit Aluminum Radiator. Features a built-in automatic transmission cooler, temperature sensor bung, and drain petcock with mounting clips.

- HZ-5556-6-KIT** Natural
 - HZ-5556-6-POL-KIT** Polished
- Overall Size:** 23-1/8"W x 23"H x 3-3/4"D
Core Size: 21-3/4"W x 16-1/2"H x 2-1/2"D



1955-57 Chevy V8 Direct Fit Aluminum Radiator. Designed for engines running a short style water pump. Features a built-in automatic transmission cooler, temperature sensor bung, and drain petcock with mounting clips.

- HZ-5557-8-KIT** Natural
 - HZ-5557-8-POL-KIT** Polished
- Overall Size:** 23-1/4"W x 23"H x 3"D
Core Size: 21-3/4"W x 16-1/2"H x 2-1/2"D

RADIATORS

ALUMINIUM RADIATORS

1959-72 CHEVY IMPALA RADIATOR LS CONVERSION - ALUMINUM

HZ-5972-AT-LS Natural
HZ-5972-AT-LS-POL Polished
HZ-5972-AT-LS-PBK Black



Overall Size: 28-5/8"W x 19-1/2"H x 3"D
Core Size: 20-3/4"W x 18-1/4"H x 2-1/4"D
 * Features Built-in Automatic Transmission Cooler.

1967-69 CHEVY CAMARO RADIATOR LS CONVERSION - ALUMINUM

HZ-6769-AT-LS Natural
HZ-6769-AT-LS-POL Polished



Overall Size: 28-1/4"W x 19-1/2"H x 3-1/4"D
Core Size: 25-3/4"W x 18-1/2"H x 2-1/4"D
 * Features Built-in Automatic Transmission Cooler.

1968-77 CHEVY CHEVELLE/ A-BODY RADIATOR WITH AND W/O - LS CONVERSION - ALUMINUM

HZ-6877-AT-LS Natural
HZ-6877-AT-LS-POL Polished
HZ-6877-AT-LS-PBK Black



HZ-6877-AT Natural
HZ-6877-AT-POL Polished

Overall Size: W: 33-7/16" x H: 18-13/16" x D: 3-1/8"
Core Size: W: 28-1/4" x H: 17-3/4" x D: 3"
 * Features Built-in Automatic Transmission Cooler.

1970-81 CHEVY CAMARO RADIATOR LS CONVERSION - ALUMINUM

HZ-7081-AT-LS Natural
HZ-7081-AT-LS-POL Polished
HZ-7081-AT-LS-PBK Black



Overall Size: 31.25"W x 19.5"H x 3"D
Core Size: 26"W x 17.75"H x 2.25"D
 * Features Built-in Automatic Transmission Cooler.

1966-80 MOPAR SMALL BLOCK CAR/ 1972-80 TRUCK RADIATOR W/AT - ALUMINUM



HZ-6680-AT Natural
HZ-6680-AT-POL Polished

Overall Size: W: 26-3/8" x H: 18-7/8" x D: 3-1/8"
Core Size: W: 22-3/8" x H: 17-3/4" x D: 3"
 * Features Built-in Automatic Transmission Cooler.

1964-66 FORD MUSTANG DOWNFLOW RADIATOR W/AT - ALUMINUM

HZ-6466-AT Natural
HZ-6466-AT-POL Polished



Overall Size: W: 19-7/8" x H: 20-1/4" x D: 3"
Core Size: W: 17-3/4" x H: 15-1/2" x D: 2-1/4"
 * Features Built-in Automatic Transmission Cooler.

ALUMINUM RADIATOR KITS

**1959-72 CHEVY IMPALA RADIATOR
LS CONVERSION - ALUMINUM**



HZ-5972-AT-LS-KIT Natural
HZ-5972-AT-LS-POL-KIT Polished
HZ-5972-AT-LS-PBK-KIT Black
Overall Size: 28-5/8"W x 19-1/2"H x 3"D
Core Size: 20-3/4"W x 18-1/4"H x 2-1/4"D
 * Features Built-in Automatic Transmission Cooler.

**1967-69 CHEVY CAMARO RADIATOR
LS CONVERSION - ALUMINUM**



HZ-6769-AT-LS-KIT Natural
HZ-6769-AT-LS-POL-KIT Polished
Overall Size: 28-1/4"W x 19-1/2"H x 3-1/4"D
Core Size: 25-3/4"W x 18-1/2"H x 2-1/4"D
 * Features Built-in Automatic Transmission Cooler.

**1968-77 CHEVY CHEVELLE/ A-BODY RADIATOR
WITH AND W/O - LS CONVERSION - ALUMINUM**

HZ-6877-AT-LS-KIT
 Natural
HZ-6877-AT-LS-PBK-KIT
 Black
HZ-6877-AT-LS-POL-KIT
 Polished
HZ-6877-AT-KIT
 Natural
HZ-6877-AT-POL-KIT
 Polished



Overall Size: W: 33-7/16" x H: 18-13/16" x D: 3-1/8"
Core Size: W: 28-1/4" x H: 17-3/4" x D: 3"
 * Features Built-in Automatic Transmission Cooler.

**1970-81 CHEVY CAMARO RADIATOR
LS CONVERSION - ALUMINUM**

HZ-7081-AT-LS-KIT
 Natural
HZ-7081-AT-LS-POL-KIT
 Polished
HZ-7081-AT-LS-PBK-KIT
 Black



Overall Size: 31.25"W x 19.5"H x 3"D
Core Size: 26"W x 17.75"H x 2.25"D
 * Features Built-in Automatic Transmission Cooler.

**1966-80 MOPAR SMALL BLOCK CAR/
1972-80 TRUCK RADIATOR W/AT - ALUMINUM**



HZ-6680-AT-KIT Natural
HZ-6680-AT-POL-KIT Polished
Overall Size: W: 26-3/8" x H: 18-7/8" x D: 3-1/8"
Core Size: W: 22-3/8" x H: 17-3/4" x D: 3"
 * Features Built-in Automatic Transmission Cooler.

**1964-66 FORD MUSTANG DOWNFLOW
RADIATOR W/AT - ALUMINUM**



HZ-6466-AT-KIT Natural
HZ-6466-AT-POL-KIT Polished
Overall Size: W: 19-7/8" x H: 20-1/4" x D: 3"
Core Size: W: 17-3/4" x H: 15-1/2" x D: 2-1/4"
 * Features Built-in Automatic Transmission Cooler.

ALUMINIUM RADIATOR FAN SHROUDS

RADIATOR FAN SHROUDS



HZ-1008-22 Natural
HZ-1008C-22 Chrome
Dimensions: 16-5/8"x16-5/8"
Fan Size: 14"
Compatible CFR Radiators: **HZ-50010**
HZ-50020



HZ-1008-24 Natural
HZ-1008C-24 Chrome
Dimensions: 18-5/8"x16-5/8"
Fan Size: 14"
Compatible CFR Radiators: **HZ-50011**
HZ-50021



HZ-1008-26 Natural
HZ-1008C-26 Chrome
Dimensions: 20-5/8"x16-5/8"
Fan Size: 14"
Compatible CFR Radiators: **HZ-50012**
HZ-50022



HZ-1008-28 Natural
HZ-1008C-28 Chrome
Dimensions: 22-5/8"x16-5/8"
Fan Size: 14"
Compatible CFR Radiators: **HZ-50014**
HZ-50024



HZ-1008-31 Natural
HZ-1008C-31 Chrome
Dimensions: 25-5/8"x16-5/8"
Fan Size: Two 12"
Compatible CFR Radiators: **HZ-50016**
HZ-50026



HZ-1009-22 Natural
HZ-1009C-22 Chrome
HZ-1009-22-PBK Black
Dimensions: 16-5/8"x18-5/8"
Fan Size: 16"
Compatible CFR Radiators: **HZ-40010**
HZ-40020
HZ-40210
HZ-40220

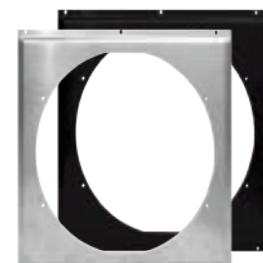

HZ-1009-24 Natural
HZ-1009C-24 Chrome
HZ-1009-24-PBK Black
Dimensions: 18-5/8"x18-5/8"
Fan Size: 16"
Compatible CFR Radiators: **HZ-40011**
HZ-40021
HZ-40211
HZ-40221

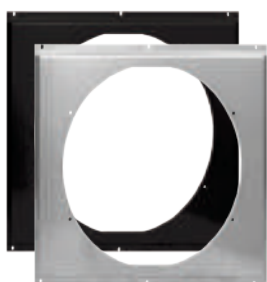

HZ-1009-26 Natural
HZ-1009C-26 Chrome
HZ-1009-26-PBK Black
Dimensions: 20-5/8"x18-5/8"
Fan Size: 16"
Compatible CFR Radiators: **HZ-40012**
HZ-40022
HZ-40212
HZ-40222
HZ-5972
HZ-5972-POL
HZ-5972-AT
HZ-5972-AT-POL



HZ-1009-28 Natural
HZ-1009C-28 Chrome
HZ-1009-28B Two 10" Fans
HZ-1009C-28B
HZ-1009-28-PBK Black
Dimensions: 22-5/8"x18-5/8"
Fan Size: 16"
Compatible CFR Radiators: **HZ-40014**
HZ-40014-AT
HZ-40024
HZ-40214
HZ-40224
HZ-6769
HZ-6769-AT



HZ-1009-31 Natural
HZ-1009C-31 Chrome
HZ-1009-31B
HZ-1009C-31B
HZ-1009-31B-PBK Black
Dimensions: 25-5/8"x18-5/8"
Fan Size: 16"
Compatible CFR Radiators: **HZ-40016**
HZ-40016-AT
HZ-40026
HZ-40216
HZ-40226
HZ-40226-O
HZ-7081
HZ-7081-AT
HZ-7081-DP

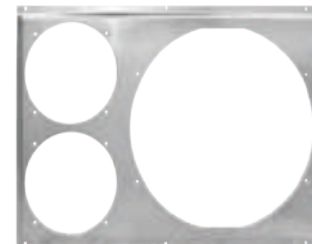

HZ-1009-31-1 Natural
HZ-1009C-31-1 Chrome
Dimensions: 25-5/8"x18-5/8"
Fan Size: One 16" Two 8"
Compatible CFR Radiators: **HZ-40016**
HZ-40016-AT
HZ-40026
HZ-40216
HZ-40226
HZ-40226-O
HZ-7081
HZ-7081-AT
HZ-7081-DP

ALUMINIUM RADIATOR FAN SHROUDS



HZ-1009-34A
HZ-1009-34B Two 12" Fans
HZ-1009C-34A
HZ-1009C-34B Two 12" Fans
Dimensions: 27-1/2"x18-1/2"
Fan Size: One 16" or Two 12"



HZ-1009-67
HZ-1009C-67
Dimensions: 22-5/8"x18-5/8"
Fan Size: Two 12"
Compatible
CFR Radiators: **HZ-6769**
HZ-6769-AT*



Fits 1955-Up Chevy Tri 5 Radiators.
HZ-1009-55
HZ-1009C-55 Chrome
Dimensions: 22-7/8"x17-1/2"
Fan Size: 16"
Compatible
CFR Radiators: **HZ-5556-6**
HZ-5557-8
HZ-5700-6



Fits 1973-95 Ford 5.0L 302 Radiators.
HZ-1009-79
HZ-1009C-79 Chrome
Dimensions: 24-5/8"x18-5/8"
Fan Size: 16"
Compatible
CFR Radiators: **HZ-79MU-ML**
HZ-79MU-AT

These fan shrouds are blank templates so you may design and drill your own electric fan, and bolt holes.



HZ-1008H-22 Natural
Dimensions: 16-5/8"x16-5/8"
Compatible
CFR Radiators: **HZ-50010**
HZ-50020



HZ-1008H-26 Natural
Dimensions: 20-5/8"x16-5/8"
Compatible
CFR Radiators: **HZ-50012**
HZ-50022



HZ-1008H-31 Natural
Dimensions: 25-5/8"x16-5/8"
Compatible
CFR Radiators: **HZ-50016**
HZ-50026



HZ-1009H-22 Natural
Dimensions: 16-5/8"x18-5/8"
Compatible
CFR Radiators: **HZ-40010**
HZ-40020
HZ-40210
HZ-40220

MECHANICAL FAN SPACERS

Has 5/8" Pilot hole and comes complete with mounting hardware in a machined finish.



HZ-1050
1/2"



HZ-1051
1"



HZ-1052
1-1/2"



HZ-1053
2"



HZ-1054
2-1/2"



HZ-1055
3"

RADIATOR CAPS



HZ-1950-POL
Finish: Polished
Pressure: 16 lbs.



HZ-1951-POL
Finish: Polished
Pressure: 16 lbs.



HZ-1952
Finish: Stainless Steel
Pressure: 22 lbs.



HZ-5010-C
Finish: Chrome
HZ-5010-POL
Finish: Polished
Pressure: 16 lbs.



HZ-5010-C-CFR
Finish: Chrome
HZ-5010-POL-CFR
Finish: Polished
Pressure: 16 lbs.



HZ-5020-Z
Finish: Zinc
Pressure: 16 lbs.

All fans have been anemometer tested to provide the most accurate CFM ratings

ELECTRIC COOLING FANS



Curved Blade

Part #	Size	CFM	Finish
HZ-1014CU	10"	1800	Black
HZ-1002CU	12"	2200	Black
HZ-1002C-CU	12"	2200	Chrome
HZ-1003CU	14"	2800	Black
HZ-1009CU	16"	2300	Black
HZ-1009C-CU	16"	2500	Chrome

Flat Blade

Part #	Size	CFM	Finish
HZ-1001-7	7"	1500	Black
HZ-1001-8	8"	1700	Black

Note: Check arrow on fan blade for proper rotation prior to changing.

PULLER MODE WIRING

BLUE WIRE - CHASSIS GROUND, NEGATIVE (-)
BLACK WIRE - WIRE -, 12V POSITIVE (+)

PUSHER MODE WIRING

BLUE WIRE - WIRE -, 12V POSITIVE (+)
BLACK WIRE - CHASSIS GROUND, NEGATIVE (-)

**Remove nut from center of cooling fan shaft. Remove fan blade. Flip fan blade around and reinstall on shaft. Make sure blade is properly secure with nut, with loc-tite, but do not over tighten.

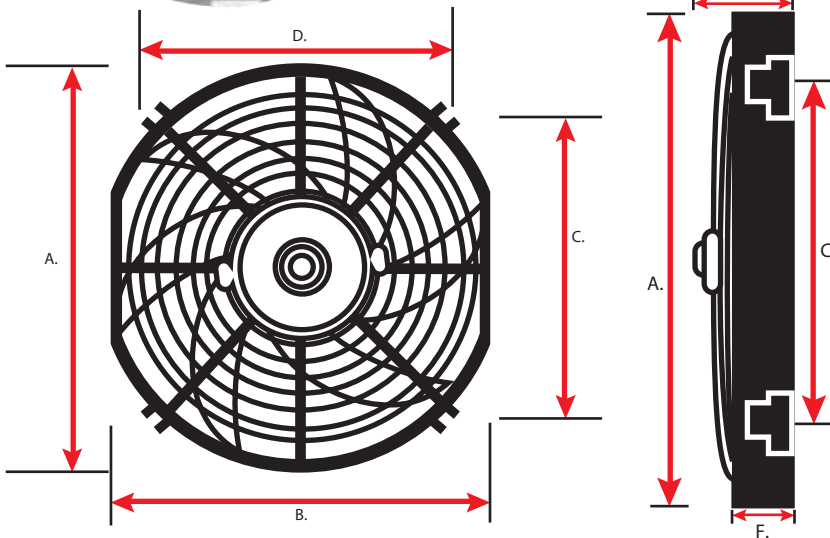

Part #	Size	A.	B.	C.	D.	E.	F.
HZ-1009CU	16"	16.25"	15.71"	14.17"	8.1"	3.5"	1.10"
HZ-1009C-CU	16"	16.25"	15.71"	14.17"	8.1"	3.5"	1.10"
HZ-1003CU	14"	14.84"	13.86"	13.38"	7.09"	2.40"	1.57"
HZ-1002CU	12"	12.91"	12.20"	11.69"	6.18"	2.6"	1.42"
HZ-1002C-CU	12"	12.91"	12.20"	11.69"	6.18"	2.6"	1.42"
HZ-1014CU	10"	11.38"	10.71"	9.88"	5.71"	2.83"	1.42"
HZ-1001-8	8"	8.34"	7.87"	5.98"	5.98"	2.20"	1.02"
HZ-1001-7	7"	8.27"	7.95"	5.95"	5.95"	2.11"	1.24"



Universal Electric Fan Mounting Brackets Kit. Designed to mount 12" or 16" electric fans to your 19" tall radiator. Includes hardware.

HZ-1007-KIT

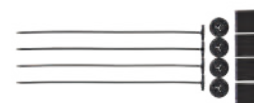

Universal Nylon Tie Mounting Kit. Includes four 6-1/2" zip-tie pastic rods, four foam mounting pads and four lock tab clips. Secures all electric fans, and oil or transmission coolers to any vehicle.

HZ-406-KIT

ALUMINUM RADIATOR MOUNTING KITS

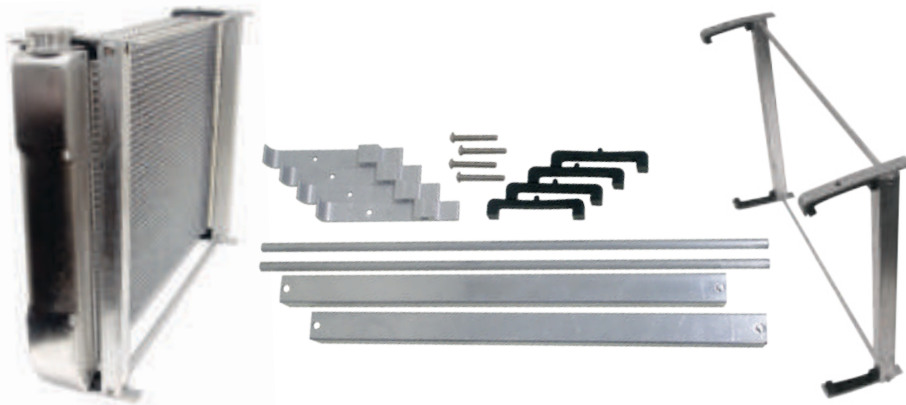

CFR Universal Aluminum Radiator Mounting Kit.
Designed to hold CFR radiators in place. CFR Performance universal mounting kit makes the installation of your radiator simple.

Part #	Size
HZ-41010	22" x 19"
HZ-41011	24" x 19"
HZ-41012	26" x 19"
HZ-41014	28" x 19"
HZ-41016	31" x 19"
HZ-51010	22" x 16-1/2"
HZ-51011	24" x 16-1/2"
HZ-51012	26" x 16-1/2"
HZ-51014	28" x 16-1/2"
HZ-51016	31" x 16-1/2"

AIR CONDITIONING PUMP



HZ-8900-C Chrome



HZ-8900 Natural

Sanden Type Air Compressor. Chrome housed pump for v-belt type pulleys.



HZ-8901-C Chrome
508 Housing Serpentine.



HZ-8902 Natural
HZ-8902-C Chrome
SD7 Serpentine.

UNIVERSAL FAN SHROUDS



3" Wide x 20" Dia.
HZ-9453
Chrome
HZ-9453-PBK
Black EDP



5-1/2" Wide x 20" Dia.
HZ-9454
Chrome
HZ-9454-PBK
Black EDP

STAINLESS STEEL RADIATOR HOSE KITS



CFR-7302

- CFR-7302** Black 12"
- CFR-7305** Black 24"
- CFR-7308** Black 36"
- CFR-7311** Black 48"



CFR-7305

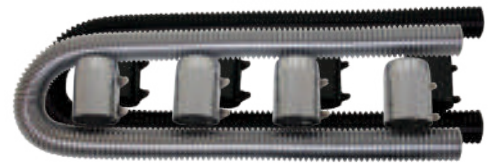

CFR-7311

Stainless Steel Hose Kits.

All kits include a stainless steel radiator hose, stainless steel ends, 1-1/4", 1-1/2" and 1-3/4" reducers, and hose clamps.

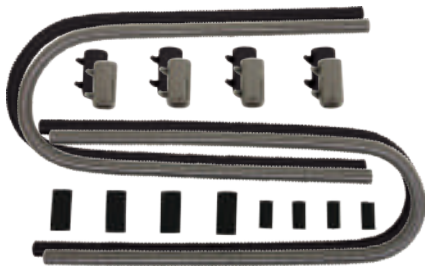

STAINLESS STEEL HEATER HOSE KITS

Universal Stainless Steel Hose Kit.

All kits include two 44" stainless steel heater hoses, four stainless steel ends, four 5/8" reducers, four 3/4" rubber sleeves and four hose clamps.

- HZ-7314**
- HZ-7314-PBK** Black

RADIATOR OVERFLOR TANKS

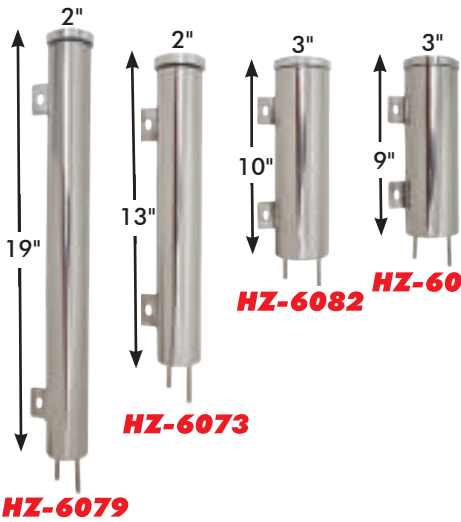

Stainless Steel Radiator Overflow Tanks. Universal polished stainless steel radiator reservoir tanks feature a twist-on style aluminum cap and come complete with hardware and mounting brackets.

HZ-6082 **HZ-6081** Overflow tank with release valve

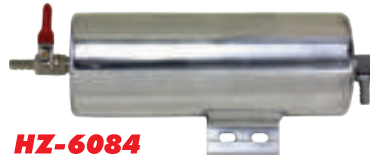

HZ-6084

Part #	Size	Capacity	Dia.
HZ-6071	11"	16 oz	2"
HZ-6073	13"	20 oz	2"
HZ-6075	15"	24 oz	2"
HZ-6077	17"	28 oz	2"
HZ-6079	19"	32 oz	2"

Part #	Size	Capacity	Dia.
HZ-6081	9"	23 oz	3"
HZ-6082	10"	26 oz	3"
HZ-6083	16"	44 oz	3"
HZ-6084	8"	20 oz	3"



FINNED RADIATOR OVERFLOR TANKS

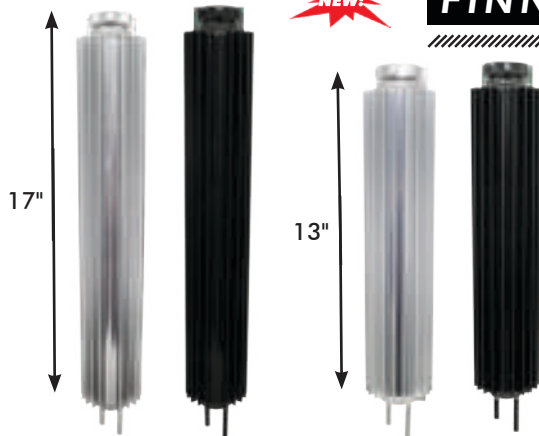

HZ-0517
HZ-0517-PBK

HZ-0513
HZ-0513-PBK

Part #	Size	Capacity	Dia.
HZ-0513 HZ-0513-PBK	13"	20 oz	2"
HZ-0517 HZ-0517-PBK	17"	28 oz	2"

WATER NECKS

All water necks include bolts and O-ring (except HZ-9228-G)



SBC/BBC
(Early Model) V8
HZ-9228-C-KIT
Chrome Steel
HZ-9228-PBK-KIT
Black EDP
HZ-9228-G-KIT
Chrome Steel with Gasket



SBC/BBC
(Late Model) V8
HZ-9229-C-KIT
Chrome Steel
HZ-9229-PBK - KIT
Black EDP



3/8" NPT Port
BBF 429-460
HZ-9415-C-KIT
Chrome Steel
HZ-9415-PBK-KIT
Black EDP



1/2" NPT Port
SBC/BBC 283-454
(Late Model) V8
HZ-9468-C-KIT
Chrome Steel
HZ-9468-PBK-KIT
Black EDP



90 Degree
1979-up Ford
5.0L Mustang
HZ-9713-C-KIT
Chrome Steel
HZ-9713-PBK-KIT
Black EDP



1965-75 SBF
260-351W Mustang
HZ-9714-C-KIT
Chrome Steel
HZ-9714-PBK-KIT
Black EDP



SBC BBC
Straight-Up
Aluminum
HZ-6002-POL-KIT Polished
HZ-6002-COP-KIT Copper
HZ-6002-C-KIT Chrome
HZ-6002-PBK-KIT Black EDP



SBC BBC
45 Degree Swivel
Aluminum
HZ-6003-POL-KIT Polished
HZ-6003-COP-KIT Copper
HZ-6003-C-KIT Chrome
HZ-6003-PBK-KIT Black EDP



SBC BBC
90 Degree Swivel
Aluminum
HZ-6014-POL-KIT Polished
HZ-6014-C-KIT Chrome
HZ-6014-PBK-KIT Black EDP
HZ-6014-COP-KIT Copper



SBC BBC
15 Degree Swivel
Aluminum
HZ-6015-POL-KIT Polished
HZ-6015-C-KIT Chrome
HZ-6015-PBK-KIT Black EDP
HZ-6015-COP-KIT Copper



Ford Cleveland
351 5.8L
Steel
HZ-9715-C-KIT Chrome
HZ-9715-PBK-KIT Black EDP



LS Water Neck
Aluminum
HZ-6145-POL-KIT Polished
HZ-6145-C-KIT Chrome
HZ-6145-PBK-KIT Black EDP

WATER NECKS

HIGH FLOW ALUMINUM WATER PUMPS



1955-78 Short (SWP)
SBC Mechanical Water Pump
HZ-WP2901 Natural
HZ-WP2901-C Chrome
HZ-WP2901-POL Polished

1969-84 Long (LWP)
SBC Mechanical Water Pump
HZ-WP2902 Natural
HZ-WP2902-C Chrome
HZ-WP2902-POL Polished

1965-78 Short (SWP)
BBC Mechanical Water Pump
HZ-WP2904 Natural

SBC Reverse rotation Long water pump Has 5/8" pilot (LWP)
HZ-WP2903 Natural
HZ-WP2903-C Chrome
HZ-WP2903-POL Polished



1969-87 Long (LWP)
BBC Mechanical Water Pump
HZ-WP2905 Natural

1970-87
SBF Mechanical Water Pump
HZ-WP302HP Natural

1986-93 Reverse
SBF Mechanical Water Pump
HZ-WP302L Natural
HZ-WP302L-POL Polished

SBC Reverse rotation short water pump Has 3/4" pilot (SWP)
HZ-WP2900 Natural
HZ-WP2900-C Chrome
HZ-WP2900-POL Polished

ALUMINUM TRANSMISSION COOLERS

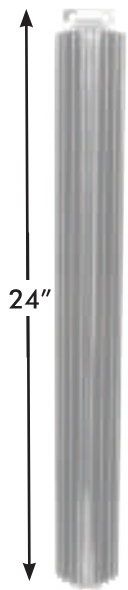

HZ-0053-1
HZ-0053-1-PBK

HZ-0052-1
HZ-0052-1-PBK

HZ-0051-1
HZ-0051-1-PBK

HZ-0050-1
HZ-0050-1-PBK

Part #	Size	Fitting
HZ-0050-1 HZ-0050-1-PBK	12"	1/4" NPT
HZ-0051-1 HZ-0051-1-PBK	15"	1/4" NPT
HZ-0052-1 HZ-0052-1-PBK	18"	1/4" NPT
HZ-0053-1 HZ-0053-1-PBK	24"	1/4" NPT
HZ-0054-1	30"	1/4" NPT



HZ-0050-1
Dual Line

DISTRIBUTORS



Steel Clamp Ford V8 OEM Style **HZ-1092**
Steel Clamp Chevy V8 Competition Style **HZ-1093**
Steel Clamp Chevy V8 OEM Style **HZ-1094**
Chevy/GM Billet Aluminum Distributor Hold-Down Clamps. **HZ-1091-RED** **HZ-1091-BLUE** **HZ-1091-CHROME**
Steel Clamp Ford FE Competition Style **HZ-1095**



ALUMINUM SPARK PLUG WIRE BOOT HEAT SHIELD PROTECTOR
CFR-3700-SIL Silver **CFR-3700-RED** Red
CFR-3700-PBK Black **CFR-3700-PBL** Blue



UNIVERSAL RFID KEY LESS CAR ALARM SYSTEM W/PUSH START BUTTON
CFR-2204
RFID KEY FOB **HZ-2206**
RFID KEY CARD **HZ-2205**

Part #	Application	Description	
HZ-D6001	Chevy/GM SB/BB	HEI Distributor Features: 1) Fully CNC machined. 2) Polished housing. 3) Adjustable vacuum advance canister. 4) Premium caps with brass terminals. 5) Low saturation ignition module. 6) High output 50K volt coil through 7,500 RPM. 7) 4340 Chromoly steel bottom gear. 8) True spark alignment.	
HZ-D6002	Ford SB 289/302W		
HZ-D6003	Ford SB 351W		
HZ-D6004	Ford 351C/460		
HZ-D6006	Chrysler 318		
HZ-D6009	Oldsmobile		
HZ-D7001	Chevy/GM SB/BB		Ready-to-Run Distributor Features: 1) Maintenance-free magnetic pickup. 2) Increased output internal ignition. 3) Oversized steel shaft w/ extra long sintered bushing. 4) Adjustable mechanical advance. 5) Vacuum advance canister.
HZ-D7002	Ford 289/302W		
HZ-D7003	Ford 351W		
HZ-D7004	Ford 351C/460		
HZ-D7007	Chrysler 440		

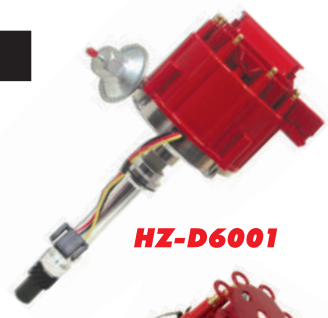

HZ-D6001



HZ-D7002

IGNITION COILS

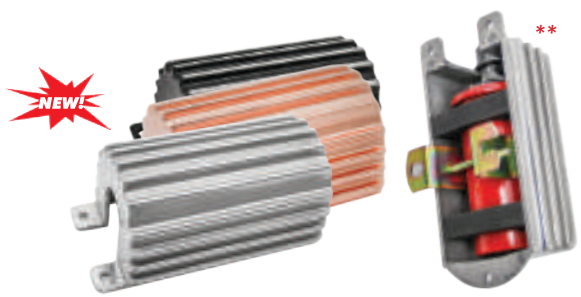

ALUMINUM FINNED CANNISTER ROUND IGNITION COIL COVER
HZ-2045-POL Polished **HZ-2045-POL-KIT** Polished**
HZ-2045-PBK Black **HZ-2045-PBK-KIT** Black**
HZ-2045-COP Copper **HZ-2045-COP-KIT** Copper**



ALUMINUM FINNED TFI SQUARE IGNITION COIL COVER
HZ-2040-POL Polished **HZ-2040-POL-KIT** Polished**
HZ-2040-PBK Black **HZ-2040-PBK-KIT** Black**
HZ-2040-COP Copper **HZ-2040-COP-KIT** Copper**



CANNISTER ROUND IGNITION COIL
HZ-2046 Red



Chevy/GM Universal Steel Chrome Canister Coil Bracket, designed after factory GM mount.
HZ-9366



64-73 Ford Universal Steel Chrome Canister Coil Bracket, Universal fit
HZ-9650



HIGH OUTPUT E-CORE SUPER VOLT IGNITION COIL
HZ-2042 Black

TRANSMISSION / THROTTLE CABLE KITS

TRANSMISSION KICKDOWN CABLE KITS



**Chevy/GM Turbo
TH-350
HZ-2003**



**Chevy/GM Turbo
TH-350 (Tuned-Port)
HZ-2004**



**Chrysler 727
HZ-2005**



**Chevy/GM 4L60
HZ-2006**



**Chevy/GM 700R4
(Tuned-Port)
HZ-2007**



**Chevy/GM 700R4
HZ-2008**



**Ford C4
HZ-2011**



**Ford C6
HZ-2012**



**Chrysler 904
HZ-2009**



**Chevy/GM Turbo
TH-350 (56")
HZ-6053**

THROTTLE CABLE KITS



**Tuned-Port - 24"
HZ-2010**



**Universal - 24"
HZ-6054**



**Universal - 36"
HZ-6054X**

THROTTLE RETURN SPRING KITS



**Chevy/GM Small Block Chrome Steel
Throttle Return Spring Bracket
HZ-2291 HZ-2291-PBK**

**Ford Small Block Chrome Steel
Throttle Return Spring Bracket
HZ-2297**

CHROME HOLLEY FUEL LINES

HZ-2197

Chrome 4BBL Holley Fuel Line

9-5/16"

HZ-2198

Chrome 4BBL Holley Fuel Line

8-21/32"



FUEL BLOCK OFF PLATES

Fuel Pump Block Off Plates. Designed to block off the fuel pump mounting on the cylinder block when a mechanical fuel pump is not used.



**HZ-2058-C
Chrome Steel**



**HZ-6012-POL
Polished Aluminum**

**HZ-6012-C
Chrome Aluminum**

Chevy Big Block

396-402-427-454

Chrysler/Mopar Small Block

273-318-340-360

Chrysler/Mopar Big Block

361-383-400-440

Ford, Lincoln and Mercury
Small & Big Block

All engines except
351C-351M-400



**HZ-2057-C
Chrome Steel**



**HZ-6013-POL
Polished Aluminum**

**HZ-6013-C
Chrome Aluminum**

Chevy Small Block

283-302-305-307-
327-350-383-400



**HZ-2059-C
Chrome Steel
HZ-2059-PBK
Black EDP**

Fuel Pump Mounting Plate

Chevy Small Block

283-302-305-307-
327-350-383-400

ALTERNATORS

*Remanufactured in the U.S.A.

Chevy/GM Alternator.



HZ-3908-C Chrome
HZ-3908-PBK Black

Aluminum chevy alternator 120 amp cs 130 one wire



HZ-3902 Natural
HZ-3902-C Chrome
HZ-3902-PBK Black

Amp 100
Type Internal
Has a 1 wire plug or can be used as a 3 wire set up V-Belt

LS-1 Alternator



HZ-3906 Natural
HZ-3906C Chrome

Amp 120
Type Internal
1-Wire

1966-91 Ford/Mercury/Jeep Alternator.



HZ-3904C Chrome
Amp 110
Type External

***HZ-3907-C** Chrome
***HZ-3907** Natural
HZ-3907-PBK Black
uses a 3 wire regulator

1985-93 Ford/Mercury Alternator.

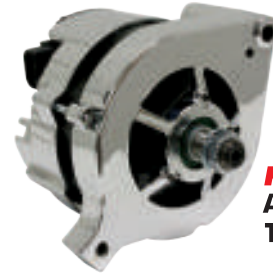

HZ-3905C Chrome
Amp 75
Type Internal

MINI STARTERS

All HZ-S2107's have a clockable mounting base & will handle up to 11.1 compression ratio.



HZ-S2104



HZ-S2107-C



HZ-S2107-PBK



HZ-S2107-RED

Part #	Description	HP	Ratio	Finish
HZ-S2104	Chevy Small/Big Block Delco Style High Torque Staggered Bolt Pattern Starter	3	4.4:1	Standard
HZ-S2107-C	Chevy Small/Big Block Tilton Style High Torque Gear Reduction Starter	3	15:1	Chrome
HZ-S2107-PBK	Chevy Small/Big Block Tilton Style High Torque Gear Reduction Starter	3	15:1	Black
HZ-S2107-RED	Chevy Small/Big Block Tilton Style High Torque Gear Reduction Starter	3	15:1	Red

MASTER CYLINDER COVERS



HZ-9102
HZ-9102-PBK
Dual Bail Cover
Oval



HZ-9100
HZ-9100-PBK
Single Bail Cover
Oval



HZ-9101
HZ-9101-PBK
Single Bail Cover
Rectangle

POWER STEERING PUMPS

POWER STEERING



HZ-3911C Chrome
HZ-3911-PBK Black

1955-72 Chevy/GM Chrome Power Steering Pumps. They are the Saginaw style and use a key way type power steering pulley.



HZ-3910C Chrome
HZ-3910-PBK Black

Early Chevy/GM Chrome Power Steering Pumps. They are the Saginaw style and use a key way type power steering pulley.



HZ-3913 Natural
HZ-3913C Chrome

Type II Chevy/GM Power Steering Pump. They use a press fit type power steering pulley.



HZ-3915-PBK Black
Early Model Ford
power Steering pump
with plastic reservoir.



HZ-3916-PBK Black
Late Model Ford
power Steering pump
with plastic reservoir.



HZ-3914 Natural
Type II Chevy/GM Power Steering Pump. With black plastic reservoir they use a press fit type power steering pulley

POWER STEERING OVERFLOW TANKS

POWER STEERING CAP COVER



HZ-9257
Chrome Plastic Power
Steering Cap Cover.
Snaps over existing
OEM Saginaw cap.



1 Fitting
HZ-6080A



2 Fittings
HZ-6080A-1



3 Fittings
HZ-6080A-2

Universal Power Steering Overflow/Recovery Tanks. Lightweight polished aluminum reservoir tanks are 6" tall and come with a polished billet aluminum cap and integrated bracket.

13-1/2" CHROME ALUMINUM STEERING WHEELS

13-1/2" Chrome Billet Aluminum Steering Wheels. Universal chrome plated billet aluminum steering wheels feature a black leather half wrap over the front and billet chrome finger notches on the back. Mounting pattern: 9 hole.



HZ-5506



HZ-5507



HZ-5508



HZ-5511



HZ-5512



HZ-5515



HZ-5516



HZ-5520



HZ-5520-9

STEERING WHEEL HORN BUTTONS & ADAPTORS

1967-94 Chevy/GM Chrome Plated Billet Aluminum Steering Wheel Horn Buttons & Adaptors. Fits 1967-94 Chevy/GM splined steering columns. Available in 9 hole bolt pattern.



9 Hole
ID: 3-1/4" OD: 3-1/2"
HZ-5500-1 - Smooth



9 Hole
ID: 3-1/4" OD: 4-5/8"
HZ-5500 - Smooth



9 Hole
ID: 3-1/4" OD: 4-5/8"
HZ-5500-W - Wood Hydrographic
HZ-5500-H - Carbon Hydrographic

HZ-5530-PBK
Black Leather

HZ-5530-W
Wood Hydrographic



HZ-5530-C
Chrome plastic

HZ-5530-H
Carbon Hydrographic

Steering Wheel Half Wrap



9 Hole
ID: 3-1/4" OD: 4-3/8"
HZ-5502 - Smooth



9 Hole
ID: 3-1/4" OD: 4-3/8"
HZ-5502-W - Wood Hydrographic
HZ-5502-H - Carbon Hydrographic

BILLET ALUMINUM REAR VIEW MIRRORS

Rear view mirrors are universal style and windshield mount.

Part #	Size	Style	Finish
HZ-1005-C	9-3/8" x 2-5/16" x 3/8"	Flamed	Chrome
HZ-8625	9-3/8" x 2-5/16" x 3/8"	Ball Milled	Polished
HZ-8625-C	9-3/8" x 2-5/16" x 3/8"	Ball Milled	Chrome
HZ-5535	11-1/4" x 2-5/8" x 1/4"	Smooth	Polished
HZ-5535-C	11-1/4" x 2-5/8" x 1/4"	Smooth	Chrome
HZ-5535-1	11-1/4" x 2-5/8" x 1/4"	Ball Milled	Polished
HZ-5535C-1	11-1/4" x 2-5/8" x 1/4"	Ball Milled	Chrome
HZ-5535-2	11-1/4" x 2-5/8" x 1/4"	Flamed	Polished
HZ-5535C-2	11-1/4" x 2-5/8" x 1/4"	Flamed	Chrome
HZ-5536	11" x 3" x 1/4"	Poker Suits	Polished
HZ-5536-C	11" x 3" x 1/4"	Poker Suits	Chrome
HZ-5544	5-7/8" x 4-1/2" x 3/8"	Poker Spade	Polished
HZ-5544-C	5-7/8" x 4-1/2" x 3/8"	Poker Spade	Chrome



HZ-5535-C
HZ-5535-PBK



HZ-8625



HZ-5535C-1



HZ-1005-C



HZ-5535-2



HZ-5544-C



HZ-5536-C

ALUMINUM STREET ROD PEDALS



**Street Rod Gas Pedal
Firewall Mount**

HZ-8600-C Chrome **HZ-8600-PBK** Black
HZ-8600-POL Polished



**Street Rod Gas Pedal
Firewall Mount**

HZ-8601-C Chrome **HZ-8601-PBK** Black
HZ-8601-POL Polished



**1955-57 Chevy/GM Gas
Pedal - Firewall Mount**

HZ-8854RC Chrome **HZ-8854-PBK** Black
HZ-8854-POL Polished



**Street Rod Gas
Pedal - Floor Mount**

HZ-8503-C Chrome **HZ-8503-PBK** Black
HZ-8503-POL Polished



Street Rod Brake Pad
HZ-8500-C Chrome
HZ-8500-POL Polished
HZ-8500-PBK Black



Street Rod Brake Pad
HZ-8501-C Chrome
HZ-8501-POL Polished
HZ-8501-PBK Black



**Street Rod Dimmer
Switch Pad**
HZ-8514-C Chrome
HZ-8514-POL Polished
HZ-8514-PBK Black

ALUMINUM DOOR HANDLES & WINDOW CRANKS



Universal Plated Billet Aluminum Door Handles & Window Cranks. All sets come with two door handles or two window cranks, two splined shaft adapters, two square shaft adapters, and two round shaft adapters.

HZ-2100-1 | HZ-2100-1-PBK



HZ-2101-1 | HZ-2101-1-PBK



Part #	Item Description	Length	Qty
HZ-2100	Chrome Door Handles	4-1/2"	2
HZ-2100-1	Chrome Door Handles	3-1/2"	2
HZ-2101	Chrome Door Window Cranks	4-1/2"	2
HZ-2101-1	Chrome Door Window Cranks	3-1/2"	2



HZ-2100 | HZ-2100-PBK

HZ-2101 | HZ-2101-PBK

ALUMINUM COLUMN DRESS UP KITS & SHIFTER ARMS



1969-89 Chevy/GM Billet Aluminum Steering Column Dress Up Kit. Kit includes turn signal (7"), tilt wheel lever (5-3/8") and hazard knob (1").

HZ-6062KIT-1-POL (Polished) **HZ-6062KIT-1-PBK** Black
HZ-6062KIT-1C (Chrome)



1973-94 Chevy/GM Billet Aluminum Column Shifter Arm. Fits 1973-94 Chevy/GM cars and trucks.

HZ-6063-POL-ARM (Polished) **HZ-6063-PBK-ARM** Black
HZ-6063C-ARM (Chrome)

ALUMINUM OPTIMA BATTERY TRAYS



Battery Not Included

HZ-9327

Smooth Polished
10" x 6-3/4"
Group 34/78



HZ-9328C-1

Ball Milled Chrome
11-3/4" x 7-3/4"
Group 35



HZ-9329

Smooth Polished
11-3/4" x 7-3/4"
Group 75/25

HZ-9327-POL Smooth Polished
HZ-9327-1 Ball Milled Polished
HZ-9327C-1 Ball Milled Chrome

HZ-9328-C Smooth Chrome
HZ-9328C-1 Ball Milled Chrome

HZ-9329-POL Smooth Polished
HZ-9329-C Smooth Chrome
HZ-9329-1 Ball Milled Polished
HZ-9329C-1 Ball Milled Chrome

HOOD PINS



HZ-4051-C

HZ-4051-GOLD

HZ-4051-SILVER

HZ-4051-BLUE

HZ-4051-BLACK

HZ-4051-RED

Aluminum Hood Pin Kit (flip over style).
Kit Includes:

- 2 - 1/2" x 4" Chrome Steel Pins.
- 2 - 2-1/4" Steel Scuff Plates.
- 2 - 1/4" Flip Over Rings.
- 4 - 3/8" Jam Nuts.



HZ-4049-C-KIT
(flip over style)

Chrome Steel Hood Pin Kit Kit Includes:

- 2 - 1/2" x 4" Chrome Steel Pins.
- 2 - 2-1/2" Steel Scuff Plates.
- 2 - 3/16" Flip Over Rings.
- 4 - 1/2" Jam Nuts.
- 2 - Lanyards



HZ-4050-C-KIT
* Does not include lanyards



HZ-160
Hood Boss
1/2"-20 x 7/8" Tall
Raw Steel



HZ-4053
Scuff Plate
2-1/2" Outer Dimension
1/2" Inner Dimension
Stainless Steel



HZ-4055
Flip Over Pin
1/4" Pin
Chrome Steel

STEEL RADIATOR SUPPORT PANELS

All radiator support bars and radiator support panels come with mounting bolts.



1970-81 Chevy Camaro
Standard: **HZ-9425-C** Chrome
(23-7/8" x 5-1/4") **HZ-9425-PBK** Black EDP



1968-73 Chevy Chevelle, 1968-79 Chevy Nova
Standard: **HZ-9427-C** Chrome
(24" x 5-1/4") **HZ-9427-PBK** Black EDP



1970-81 Chevy Camaro
Heavy-Duty: **HZ-9426-C** Chrome
(28-11/16" x 5-1/2") **HZ-9426-PBK** Black EDP



1968-77 Chevy Chevelle
Heavy-Duty: **HZ-9428-C** Chrome
(31-1/8" x 5-3/4") **HZ-9428-PBK** Black EDP

STEEL RADIATOR SUPPORT BARS



1967-69 Chevy Camaro/Pontiac Firebird
HZ-9175-C Chrome
HZ-9175-PBK Black EDP



1970-81 Chevy Camaro
HZ-9176-C Chrome
HZ-9176-PBK Black EDP

MUSTANG HOOD STRUTS



HZ-4000-C **HZ-4000-PBK**
Hood strut lift kit 2005-13 Mustang

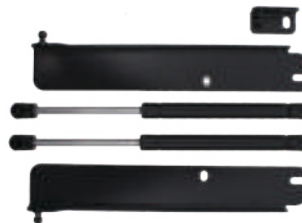

HZ-4001-PBK
Hood strut lift kit 1994-2004 Mustang



HZ-4002-PBK
Hood strut lift kit 1979-1993 Mustang

ALUMINUM HOOD LATCHES

Billet Aluminum upper hood latch 1967-81 Chevy Camaro



HZ-7530-C



HZ-7530-PBK



HZ-7530-POL

RAMS HORN SMALL BLOCK CHEVY MANIFOLDS



Fits most small block Chevy applications and provides optimal clearance for angle plug heads. Complete with mounting hardware and gaskets. Offers a distinctive vintage performance look with the durability of iron.

HZ-9995-C
Chrome

HZ-9995-CER-SIL
Ceramic Silver

HZ-9995-CER-PBK
Ceramic Black

HZ-9995-R
Raw

CHEVY SMALL BLOCK - HUGGER STYLE HEADERS



1955-UP Chevy Small Block "Hugger" Style Headers. These 1-5/8" heavy-duty "Hugger" style headers have a 3/8" thick flange and fit 1955-UP Chevy small block 265-283-305-307-327-350-383-400 engines. Comes with collector reducers, bolts & gaskets. *NOTE: Will not work with angled spark plugs, or clear center motor mount.*

HZ-9994-S
Stainless Steel

HZ-9994-PBK
Black

HZ-9994-CER
Ceramic

CAMARO/CHEVELLE/NOVA/EL CAMINO - HEADERS

Compatible Models: 1967-81 Camaro (will not fit Z28 or 1967-69 Camaro w/ A/C). 1968-77 Chevelle. 1964-87 El Camino. 1964-83 Malibu. 1970-87 Monte Carlo. 1968-79 Chevy II/Nova.

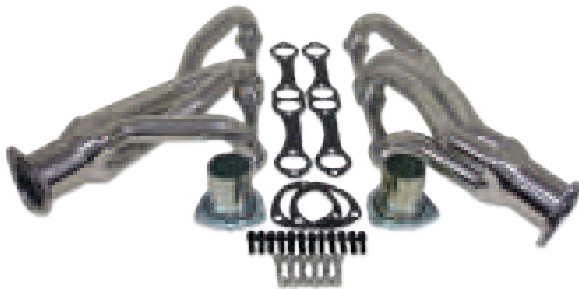

Chevy Small Block "Shorty" Style Headers. These "Shorty" style headers have 1-5/8" tubing, a 3/8" flange, and a big 3" collector end. Includes studs, nuts & flange gaskets. *NOTE: Driver side is 25" total length, Passenger side is 26" total length. Will not fit Saginaw close ratio 825 power steering box.*

HZ-9998-S
Stainless Steel

HZ-9998-PBK
Black

HZ-9998-CER
Ceramic

Will not work with angled spark plugs.

TRI-5 HEADERS



Chevy Small Block Headers. Tri-5 tight fit block hugger headers fits 1955-57 w/ 1.75" tubes and 2.5" collectors and 3/8" flange.

HZ-9993-S
Stainless Steel

HZ-9993-PBK
Black

HZ-9993-CER
Ceramic

CHEVY IMPALA LS HEADERS



CHEVY IMPALA LS CONVERSION HEADERS

Full 1 5/8" Primaries 2 1/2" Collector V8 Engines Only 4.8L, 5.3L, 5.7L, 6.0L, 6.2L Engines CNC Machined Flanges Polished Stainless Steel For LS series engine swaps only"

HZ-5023-S
Stainless Steel

Vehicle Applications:

- 1923-1954 Chevrolet Cars & Trucks
- 1923-1954 Cadillac Cars
- 1958-1964 Chevrolet Impala & Biscayne
- 1950-1964 Chevrolet Bel Air
- 1953-1967 Chevrolet Corvette
- 1955-1961 Chevrolet Nomad
- and so on....

CHEVY LS HEADERS



CHEVY LS CONVERSION HEADERS

For Chevrolet LS1 LS6 LSX LS2 Universal Stainless Shorty Engine Swap Header Redesigned for more frame and transmission clearance More details available on our website Stainless LS1 Engine Swap Headers (pair) Works well with cars that have a center crossmember under the engine 1 5/8 Primary Tubes 2 1/2 Collector 3/8 Thick Header Flange Professionally Tigged Welds Includes Header Gaskets, Starter Tubes w/ o2 Bungs, and Collector Bolts Angled spark plug boots required for clearance
Application: 1960's, 1970's Camaro, Chevelle, Nova, Firebird V8 Engines Only 4.8L, 5.3L, 5.7L, 6.0L, 6.2L Engines

HZ-5021-S
Stainless Steel

CHEVY LS HEADERS



CHEVY LS CAST IRON MANIFOLDS

- LS-Swap Cast Iron Exhaust Manifolds
- For Installing Chevy LS Engines
- 2-1/4" Collectors
- Mid-Length Design

- HZ-9988-C**
Chrome
- HZ-9988-CER-PBK**
Ceramic Black
- HZ-9988-CER-SIL**
Ceramic Silver
- HZ-9988-R**
Raw

CHEVY LT MANIFOLDS



CHEVY LT CAST IRON EXHAUST MANIFOLDS

- LS-Swap Cast Iron Exhaust Manifolds
- For Installing Chevy LT Gen V Engines to swap into an older model car
- 2-1/2" Collectors
- Mid-Length Design

- HZ-9980-C**
Chrome
- HZ-9980-CER-SIL**
Ceramic Silver
- HZ-9980-CER-PBK**
Ceramic Black
- HZ-9980-R**
Raw

CHEVY/GMC TRUCK HEADERS



1988-95 Chevy Small Block Truck Headers. Specially designed for Chevy/GMC pickup trucks. Medium length will fit both 2WD & 4WD trucks with 305/5.0L or 350/5.7L engines. Comes with bolt-on reducers, exhaust gaskets, collector gaskets & bolts. Heavy-duty 1-5/8" tube diameter, 3" collectors and 3/8" thick flange. Also features an O2 oxygen sensor bung.

HZ-5018-S
Stainless Steel

HZ-5018-PBK
Black

HZ-5018-CER
Ceramic

FORD 5.0 MUSTANG - SHORTY STYLE HEADERS

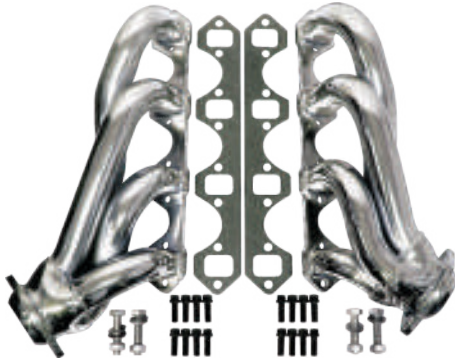

1986-93 Ford Mustang 5.0L "Shorty" Style Headers. These 1-5/8" steel "Shorty" style headers fit 1986-93 Ford Mustangs with (302) 5.0L engines. Includes bolts & gaskets.

HZ-5001-S
Stainless Steel

HZ-5001-PBK
Black

HZ-5001-CER
Ceramic

*All headers are not 50 state legal & can not be used on emission controlled vehicles.

FORD SMALL BLOCK HEADERS



Ford Small Block Headers. Fits 1963-77 260-302 5.0 mustang/cougar/falcon, tube headers w/ 1-5/8" tubes and 3" collectors.

HZ-5003-S
Stainless Steel

T304 Stainless Steel

FORD TRI-Y HEADERS

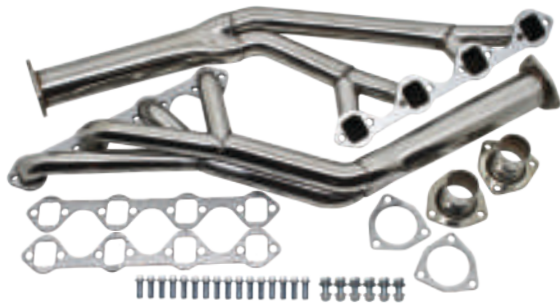

Ford Tri-Y Headers. Fits 1964-70 260-289-302 mustang, tube headers w/ 1-1/2" tubes and 2.5" collectors. Will not fit GT-40p Heads or AOD Transmission.

HZ-5004-S
Stainless Steel

T304 Stainless Steel

CHEVY/GM CAR

DIFFERENTIAL COVERS



HZ-5078-POL



HZ-5082-POL



HZ-4787-C



**HZ-4135-C
HZ-4135-PBK**



HZ-9538-C



**HZ-9190-C
HZ-9190-PBK**



**HZ-4786-C
HZ-4786-PBK**



**HZ-9583-C
HZ-9583-PBK**



**HZ-9072-C
HZ-9072-PBK**



**HZ-9584-C
HZ-9584-PBK**

Part #		Description	Ring Gear	Bolts
Steel	Aluminum			
HZ-4135-C HZ-4135-PBK	HZ-5078-POL HZ-5078-PBK	1984-87 Buick Grand National - Rear	8.5"	10
HZ-4135-C HZ-4135-PBK	HZ-5078-POL HZ-5078-PBK	1982-92 Chevy Camaro Z28 & IROC - Rear	8.5"	10
HZ-4135-C HZ-4135-PBK	HZ-5078-POL HZ-5078-PBK	1993-02 Chevy Camaro V8 (Will Not Fit Heavy-Duty) - Rear	8.5"	10
HZ-9190-C HZ-9190-PBK		1973-77 Chevy Camaro - Rear	7.5"	10
HZ-4135-C HZ-4135-PBK	HZ-5078-POL HZ-5078-PBK	1973-77 Chevy Camaro - Rear	8.5"	10
HZ-9584-C HZ-4787-C HZ-9584-PBK	HZ-5082-POL HZ-5082-PBK	1964-72 Chevy Camaro - Rear	8.875"	12
HZ-4786-C HZ-9583-C HZ-4786-PBK HZ-9583-PBK		1967-72 Chevy Camaro B, C, G, & K Axles - Rear	8.2"	10
HZ-9072-C HZ-9072-PBK		1982-UP Chevy Camaro & Pontiac Firebird - Rear	8.5"/8.6"	10
HZ-9072-C HZ-9072-PBK		1993-02 Chevy Camaro V6 & Pontiac Firebird V6 - Rear	8.5"/8.6"	10
HZ-9584-C HZ-4787-C HZ-9584-PBK	HZ-5082-POL HZ-5082-PBK	1964-72 Chevy Chevelle - Rear	8.875"	12
HZ-9584-C HZ-4787-C HZ-9584-PBK	HZ-5082-POL HZ-5082-PBK	El Camino 1964-1972	8.875"	12
HZ-4135-C HZ-4135-PBK	HZ-5078-POL HZ-5078-PBK	1982-92 Pontiac Firebird & Trans-Am - Rear	8.5"	10
HZ-9072-C HZ-9072-PBK		1994-96 Chevy Impala - Rear	8.5"/8.6"	10
HZ-4135-C HZ-4135-PBK	HZ-5078-POL HZ-5078-PBK	1964-72 Chevy/GM Intermediates - Rear	8.5"	10
HZ-9190-C HZ-9190-PBK		1964-72 Chevy/GM Intermediates - Rear	8.2"	10
HZ-9538-C		1964-72 Chevy/GM Intermediates - Rear	8.5"	10
HZ-9584-C HZ-4787-C HZ-9584-PBK	HZ-5082-POL HZ-5082-PBK	1964-72 Chevy/GM Intermediates - Rear	8.875"	12
HZ-4786-C HZ-9583-C HZ-4786-PBK HZ-9583-PBK		1964-72 Chevy/GM Intermediates B, C, G & K Axles - Rear	8.2"	10
HZ-9072-C HZ-9072-PBK		1978-UP Chevy/GM Intermediates - Rear	8.5"/8.6"	10
HZ-9584-C HZ-4787-C HZ-9584-PBK	HZ-5082-POL HZ-5082-PBK	1965-67 Chevy Nova - Rear	8.875"	12

Differential cover includes drain plug.

CHEVY/GM TRUCK & SUV

DIFFERENTIAL COVERS



HZ-4135-C
HZ-4135-PBK



HZ-4876-C
HZ-4876-PBK



HZ-4815-C
HZ-4815-PBK



HZ-9069-C



HZ-9070-C
HZ-9070-PBK

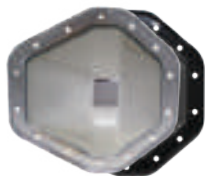

HZ-9071-C
HZ-9071-PBK



HZ-9072-C
HZ-9072-PBK



HZ-9583-C
HZ-9583-PBK



HZ-9292-C
HZ-9292-PBK



HZ-5072-POL



HZ-5073-POL



HZ-5075-POL

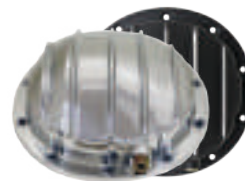

HZ-5078-POL

Part #		Description	Ring Gear	Bolts
Steel	Aluminum			
HZ-9070-C HZ-9070-PBK	HZ-5073-POL HZ-5073-PBK	1962-82 Chevy/GMC 1/2 Ton Only 2WD/4WD - Rear	8.75"	12
HZ-4786-C HZ-4786-PBK	HZ-9583-C HZ-9583-PBK	1983-87 Chevy/GMC 1/2 Ton Only 2WD/4WD - Rear	8.2"	10
HZ-4135-C HZ-4135-PBK	HZ-5078-POL HZ-5078-PBK	1988-06 Chevy/GMC 1/2 Ton 1500 Silverado, Sierra 2WD/4WD - Rear	8.5"	10
HZ-9069-C	HZ-5077-POL	1978-88 Chevy/GMC 1/2 & 3/4 Ton - Front	8.5"	10
HZ-4815-C HZ-4815-PBK	HZ-5072-POL HZ-5072-PBK	1967-77 Chevy/GMC 1/2 & 3/4 Ton 4WD - Front	Dana 44	10
HZ-4815-C HZ-4815-PBK	HZ-5072-POL HZ-5072-PBK	1988-03 Chevy/GMC 3/4 & 1 Ton 2WD/4WD - Rear	Dana 44	10
HZ-9071-C HZ-9071-PBK	HZ-5075-POL HZ-5075-PBK	1973-01 Chevy/GMC 3/4 & 1 Ton Truck & SUV - Rear	10.5"	14
HZ-9292-C HZ-9292-PBK		1981-87 Chevy/GMC 3/4 & 1 Ton Truck 2WD - Rear	9.5"	14
HZ-9071-C HZ-9071-PBK	HZ-5075-POL HZ-5075-PBK	1973-00 Chevy/GMC 3/4 & 1 Ton Silverado, Sierra Truck & SUV 2WD/4WD - Rear	10.5"	14
HZ-9072-C HZ-9072-PBK		1985-98 Chevy/GMC Astro Van, Safari Van - Rear	7.5"/7.625"	10
HZ-4135-C HZ-4135-PBK	HZ-5078-POL HZ-5078-PBK	1988-92 Chevy/GMC Blazer, Jimmy Full-Size 2WD/4WD - Rear	8.5"	10
HZ-9071-C HZ-9071-PBK	HZ-5075-POL HZ-5075-PBK	2003-UP Hummer H2 6.0L - Rear	10.5"	14
HZ-9072-C HZ-9072-PBK		1982-04 Chevy/GMC S10, S15, Envoy, Olds Bravada - Rear	7.5"/7.625"	10
HZ-9071-C HZ-9071-PBK	HZ-5075-POL HZ-5075-PBK	2001-07 Chevy/GMC Silverado, Sierra 2500 HD 6.0L - Rear	10.5"	14
HZ-9071-C HZ-9071-PBK	HZ-5075-POL HZ-5075-PBK	1973-99 Chevy Suburban 3/4 Ton 2WD/4WD - Rear	10.5"	14
HZ-9069-C	HZ-5077-POL	1977-91 Chevy Suburban 4WD - Front	8.5"	10
HZ-4135-C HZ-4135-PBK	HZ-5078-POL HZ-5078-PBK	1988-99 Chevy Suburban 2WD/4WD - Rear	8.5"	10
HZ-4135-C HZ-4135-PBK	HZ-5078-POL HZ-5078-PBK	1994-99 Chevy/GMC Tahoe, Yukon 2WD/4WD - Rear	8.5"	10
HZ-9292-C HZ-9292-PBK		1981-UP Chevy/GMC Truck - Rear	9.5"	14
	HZ-5080-POL	1995-up 3500 Dana 80 - Rear	13"	10

MOPAR CAR & TRUCK



HZ-9589-C
HZ-9589-PBK



HZ-4816-C
HZ-4816-PBK



HZ-9238-C



HZ-4815-C
HZ-4815-PBK

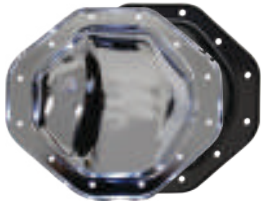

HZ-4817-C
HZ-4817-PBK



HZ-5072-PO
HZ-5072-PBK



HZ-5076-POL
HZ-5076-PBK



HZ-9589-C
HZ-9589-PBK

Part #		Description	Ring Gear	Bolts
Steel	Aluminum			
HZ-9589-C HZ-9589-PBK		1961-89 Chrysler - Rear	8.25"	10
HZ-9238-C		1999-03 Dodge 4WD Dana 25-27-30 - Front	Dana 30	10
HZ-4817-C HZ-4817-PBK		1994-UP Dodge V8 2WD/4WD - Rear	9.25"	12
HZ-4817-C HZ-4817-PBK		1974-93 Dodge Ram W100-150-200 Pickup - Rear	9.25"	12
HZ-4817-C HZ-4817-PBK		1974-08 Dodge Ram 1500 1/2 Ton - Rear	9.25"	12
HZ-4816-C HZ-4816-PBK	HZ-5074-POL HZ-5076-POL HZ-5074-PBK HZ-5076-PBK	1972-99 Dodge Ram Pickup - Front	Dana 60	10
HZ-4817-C HZ-4817-PBK	HZ-5074-POL HZ-5076-POL HZ-5074-PBK HZ-5076-PBK	1972-03 Dodge Ram Pickup - Rear	Dana 60	12
HZ-4815-C HZ-4815-PBK	HZ-5072-POL HZ-5072-PBK	1972-06 Dodge Ram Pickup 4WD - Front	Dana 44	10
HZ-4817-C HZ-4817-PBK		1974-UP Dodge Van - Rear	9.25"	12

FORD CAR - STEEL



HZ-9293-C



HZ-9465-C
HZ-9465-PBK

Part #	Description	Ring Gear	Bolts
HZ-9293-C HZ-9293-PBK	1979-94 Mercury Capri - Rear	7.5"	10
HZ-9465-C HZ-9465-PBK	1986-94 Mercury Capri - Rear	8.8"	10
HZ-9293-C HZ-9293-PBK	1978-82 Ford Fairmont - Rear	7.5"	10
HZ-9293-C HZ-9293-PBK	1979-03 Ford Mustang V8 - Rear	7.5"	10
HZ-9293-C HZ-9293-PBK	1979-00 Ford Mustang V6 and 4 Cylinder - Rear	7.5"	10
HZ-9465-C HZ-9465-PBK	1986-03 Ford Mustang V8 - Rear (will not fit Cobras)	8.8"	10

FORD TRUCK & SUV

DIFFERENTIAL COVERS



HZ-9466-C
HZ-9466-PBK



HZ-4815-C
HZ-4815-PBK



HZ-9465-C
HZ-9465-PBK



HZ-9467-C



HZ-4816-C
HZ-4816-PBK



HZ-9238-C



HZ-5072-POL



HZ-5074-POL
HZ-5074-PBK

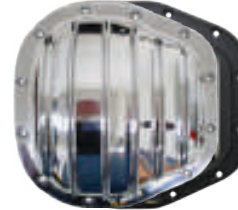

HZ-5079-POL
HZ-5079-PBK



HZ-9293-C
HZ-9293-PBK

Part #		Description	Ring Gear	Bolts
Steel	Aluminum			
HZ-9293-C HZ-9293-PBK		1984-98 Ford Aerostar Van - Rear	7.5"	10
HZ-9465-C HZ-9465-PBK		1990-97 Ford Aerostar Van V6 4.0L - Rear	8.8"	10
HZ-9293-C HZ-9293-PBK		1982-92 Ford Bronco II - Rear	7.5"	10
HZ-9465-C HZ-9465-PBK		1983-96 Ford Bronco 2WD/4WD - Rear	8.8"	10
HZ-4816-C HZ-4816-PBK	HZ-5074-POL HZ-5074-PBK	HZ-5076-POL HZ-5076-PBK 1966-85 Ford Bronco 2WD/4WD - Rear	Dana 60	10
HZ-4815-C HZ-4815-PBK	HZ-5072-POL HZ-5072-PBK	1966-79 Ford Bronco 4WD - Front	Dana 44	10
HZ-9238-C		1966-70 Ford Bronco - Front	Dana 30	10
HZ-9466-C HZ-9466-PBK	HZ-5079-POL HZ-5079-PBK	1986-06 Ford E-250, E-350 2WD/4WD - Rear	Sterling w/ 10.25"/10.50"	12
HZ-9465-C HZ-9465-PBK		1983-98 Ford E-150 Full-Size Van - Rear	8.8"	10
HZ-9465-C HZ-9465-PBK		1991-03 Ford Explorer 2WD/4WD - Rear	8.8"	10
HZ-4816-C HZ-4816-PBK	HZ-5074-POL HZ-5074-PBK	HZ-5076-POL HZ-5076-PBK 199-UP Ford Excursion Super-Duty - Front	Dana 60	10
HZ-9466-C HZ-9466-PBK	HZ-5079-POL HZ-5079-PBK	2000-05 Ford Excursion 2WD/4WD - Rear	Sterling w/ 10.25"/10.50"	12
HZ-9467-C		1999-04 Ford Expedition 2WD/4WD - Rear	9.75"	12
HZ-9465-C HZ-9465-PBK		1986-03 Ford F-150 2WD/4WD - Rear	8.8"	10
HZ-9466-C HZ-9466-PBK	HZ-5079-POL HZ-5079-PBK	1986-UP Ford F-250, F-350 2WD/4WD - Rear	Sterling w/ 10.25"/10.50"	12
HZ-4815-C HZ-4815-PBK	HZ-5072-POL HZ-5072-PBK	1966-79 Ford F-100,150,250,350 4WD - Front	Dana 44	10
HZ-4816-C HZ-4816-PBK	HZ-5074-POL HZ-5074-PBK	HZ-5076-POL HZ-5076-PBK 1966-85 Ford F-100,150,250,350 2/4WD-Rear	Dana 60	10
HZ-4816-C HZ-4816-PBK	HZ-5074-POL HZ-5074-PBK	HZ-5076-POL HZ-5076-PBK 1999-UP Ford F-250, F-350 Super-Duty - Front	Dana 60	10
HZ-4816-C HZ-4816-PBK	HZ-5074-POL HZ-5074-PBK	HZ-5076-POL HZ-5076-PBK 1972-97 Ford F-350 - Front	Dana 60	10
HZ-9465-C HZ-9465-PBK		1991-03 Mercury Mountaineer 2WD/4WD - Rear	8.8"	10
HZ-9293-C HZ-9293-PBK		1982-03 Ford Ranger - Rear	7.5"	10
	HZ-5080-POL	1995-up f350-450-550 2/4WD Dana 80-Rear	13"	10

JEEP TRUCK & SUV



HZ-9711-C
HZ-9711-PBK



HZ-9119-C
HZ-9119-PBK



HZ-4815-C
HZ-4815-PBK



HZ-4817-C
HZ-4817-PBK



HZ-9238-POL



HZ-5072-POL

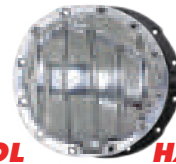

HZ-5081-POL

Part #		Description	Ring Gear	Bolts
Steel	Aluminum			
HZ-4815-C HZ-4815-PBK	HZ-5072-POL HZ-5072-PBK	1974-86 Jeep Cherokee - Front	Dana 44	10
HZ-4815-C HZ-4815-PBK	HZ-5081-POL HZ-5081-PBK	1981-84 Jeep Cherokee - Rear	Spicer 20 Corp.	12
HZ-4817-C HZ-4817-PBK		1994-99 Jeep Cherokee 4.0L - Rear	9.25"	10
HZ-9238-C		1941-03 Jeep CJ Series - Front	Dana 30	10
HZ-4815-C HZ-4815-PBK	HZ-5072-POL HZ-5072-PBK	1941-80 Jeep CJ Series - Rear	Dana 44	10
HZ-9119-C HZ-9119-PBK	HZ-5081-POL HZ-5081-PBK	1976-85 Jeep CJ, Jeep CJ-5 - Rear	Spicer 20 Corp.	12
HZ-4817-C HZ-4817-PBK		1994-99 Jeep Grand Cherokee 4.0L - Rear	9.25"	10
HZ-9238-C		1960-74 IH Scout - Front	Dana 25-27-30	10
HZ-9238-C		1960-67 IH Scout - Rear	Dana 30	10
HZ-4815-C HZ-4815-PBK	HZ-5072-POL HZ-5072-PBK	1975-80 IH Scout - Front	Dana 44	10
HZ-4815-C HZ-4815-PBK	HZ-5072-POL HZ-5072-PBK	1967-80 IH Scout - Rear	Dana 44	10
HZ-4815-C HZ-4815-PBK	HZ-5072-POL HZ-5072-PBK	1974-86 Jeep J Series Trucks - Front	Dana 44	10
HZ-4815-C HZ-4815-PBK	HZ-5072-POL HZ-5072-PBK	1974-80 Jeep J Series Trucks - Rear	Dana 44	10
HZ-9119-C HZ-9119-PBK	HZ-5081-POL HZ-5081-PBK	1981-84 Jeep J Series Trucks - Rear	Spicer 20 Corp.	12
HZ-4815-C HZ-4815-PBK	HZ-5072-POL HZ-5072-PBK	1974-86 Jeep Wagoneer - Front	Dana 44	10
HZ-9119-C HZ-9119-PBK	HZ-5081-POL HZ-5081-PBK	1981-84 Jeep Wagoneer - Rear	Spicer 20 Corp.	12
HZ-4817-C HZ-4817-PBK		1992-99 Jeep Wrangler 4.0L V6 - Rear	9.25"	10
HZ-9711-C HZ-9711-PBK		1986-90 Jeep XJ Midsize - Rear	Dana 35	10
HZ-9711-C HZ-9711-PBK		1986-90 Jeep YJ Wrangler Series - Rear	Dana 35	10

IMPORT TRUCK - STEEL

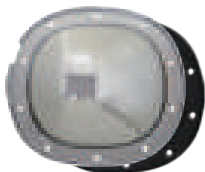

HZ-9072-C
HZ-9072-PBK



HZ-9293-C



HZ-9465-C
HZ-9465-PBK

Part #	Description	Bolts
HZ-9072-C HZ-9072-PBK	1998-03 Isuzu - Rear	10
HZ-9293-C HZ-9293-PBK	1994-03 Mazda 2300 - Rear	10
HZ-9465-C HZ-9465-PBK	1994-03 Mazda 4000 - Rear	10

DIFFERENTIAL COVER GASKETS

DIFFERENTIAL COVERS

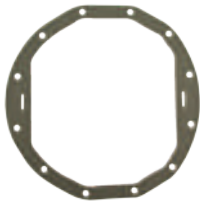

HZ-7500
GM
12 Bolt - Gray

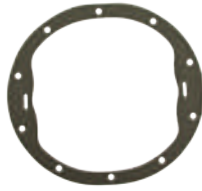

HZ-7501
Gm 8.5 In R.G.
10 Bolt - Gray

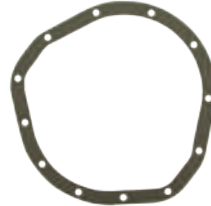

HZ-7502
GM Truck
12 Bolt - Gray

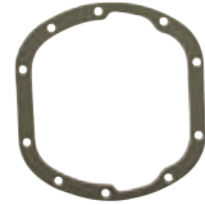

HZ-7503
Dana 30
10 Bolt - Gray

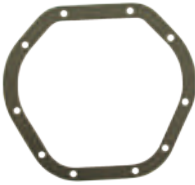

HZ-7504
Dana 44
Bolt - Gray

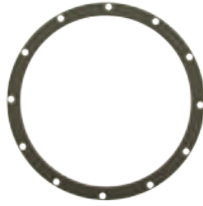

HZ-7505
Jeep Corporate
12 Bolt - Gray

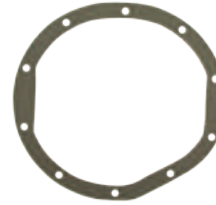

HZ-7506
GM Truck 1/2 -3/4
Ton Front Axle
10 Bolt - Gray

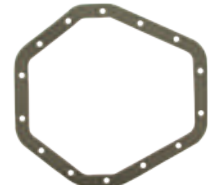

HZ-7507
GM Truck
14 Bolt - Gray

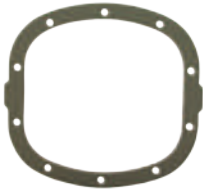

HZ-7508
GM Car 7.5" R.G.
10 Bolt - Gray

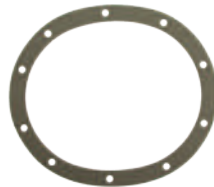

HZ-7509
Dana 35
10 Bolt - Gray



HZ-7510
Dana 60/70
10 Bolt - Gray

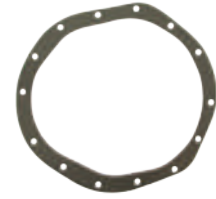

HZ-7511
GM Truck 9.5" R.G.
1/2-3/4 ton
14 Bolt - Gray

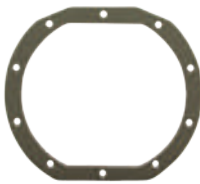

HZ-7512
Ford 7.5" R.G.
Bolt - Gray

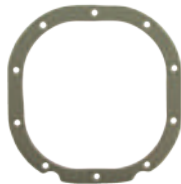

HZ-7513
Ford Truck
8.8" R.G.
10 Bolt - Gray

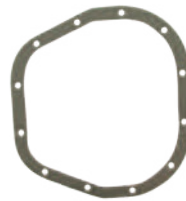

HZ-7514
Ford Truck
12 Bolt- Gray

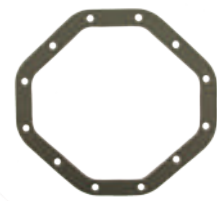

HZ-7516
Chrysler 9.25" R.G.
12 Bolt - Gray

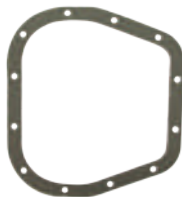

HZ-7517
Ford 9.75" R.G.
12 Bolt - Gray



HZ-7518
Dana 80
10 Bolt - Gray

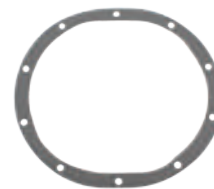

HZ-7519
Mopar 8.25" R.G.
10 Bolt - Gray



LOCK WASHER

LOCK WASHERS

Part #	Size	Finish
HZ-210-C HZ-210-PBK HZ-210-Z	STEEL 1/4" LOCK WASHER	Chrome Black Zinc
HZ-211-C	STEEL 3/8" LOCK WASHER	Chrome
HZ-212-C HZ-212-SIL HZ-212-PBK HZ-212-Z	STEEL 5/16" LOCK WASHER	Chrome Silver Black Zinc



NYLOC NUT



FASTENER NUT

NUTS

Part #	Size	Finish
HZ-118 HZ-118-PBK	FASTENER NUT FOR HZ-3911S	Natural Black
HZ-119 HZ-119-PBK	NYLOC NUT SIZE 3/8"-16	Natural Black
HZ-219	NYLOC NUT SIZE M10-1.5M	Natural



FLAT WASHER

FLAT WASHERS

Part #	Size	Finish
HZ-120 HZ-120-PBK	3/8" FLAT WASHER	Natural Black
HZ-201-C HZ-201-SS HZ-201-WZ	1/4" FLAT WASHER	Chrome Stainless White Zinc



HEX SCREW



SOCKET HEAD CAP SCREW

SCREWS

Part #	Size	Finish
HZ-125 HZ-125-PBK	STEEL HEX SCREW 5/16-18 X 3/4"	Natural Black
HZ-224-SIL HZ-224-PBK	SOCKET HEAD CAP SCREWS M8 1.25 X 25MM	Silver Black
HZ-225-C HZ-225-PBK HZ-225-SIL HZ-225-Z	SOCKET HEAD CAP SCREWS M8 1.25 X 25MM	Chrome Black Silver Zinc
HZ-231-PBK	SOCKET HEAD SCREWS M8-1.25 X 1 1/4"	Black
HZ-235-SIL HZ-235-PBK	SOCKET HEAD CAP SCREWS M8-1.25 X 35MM	Silver Black

HARDWARE



HEX BOLT

ALLEN BOLT

ALLEN BOLT

BOLTS

Part #	Size	Finish
HZ-050-SS	STAINLESS HEX BOLT 1/4-20 X 1"	Stainless
HZ-052-SS	STAINLESS HEX BOLT 1/4-20 X 3 7/8"	Stainless
HZ-100-SIL HZ-100-PBK HZ-100-Z HZ-100-NK	5/16 18 X 3/4 ALLEN HEAD BOLT W/ LOCK WASHER	Silver Black Zinc Nickel
HZ-105-SIL	ALLEN BOLT 1/4"-20 LENGTH 3/4"	Silver
HZ-111-PBK	ALLEN BOLT 3/8"-16 LENGTH 3 1/2"	Black
HZ-112-PBK	ALLEN BOLT 3/8"-16 LENGTH 3 1/4"	Black
HZ-113-PBK	ALLEN BOLT 3/8"-16 LENGTH 2 1/2"	Black
HZ-114-PBK HZ-114-NK	ALLEN BOLT 3/8"-16 LENGTH 2 1/4"	Black Nickel
HZ-115-PBK	ALLEN BOLT 3/8"-16 LENGTH 3/4"	Black
HZ-116-PBK	ALLEN BOLT 3/8 24 LENGTH 1"	Black
HZ-117-PBK	ALLEN BOLT 5/16"-24 X 3/4"	Black
HZ-121	ALTERNATOR TOP 5/16"-18 3/4" BOLT	Natural
HZ-126	ALLEN BOLT SIZE 3/8"-16 LENGTH 5"	Natural
HZ-127	ALLEN BOLT 3/8"-16 LENGTH 11 1/16"	Natural
HZ-147	HEX BOLT 5/16 18 X 3/4"	Natural
HZ-148	HEX BOLT 5/16 18 X 1"	Natural
HZ-150-C HZ-150-PBK HZ-150-Z	HEX BOLT 1/4-20 X 5/8" GRADE 8	Chrome Black Zinc
HZ-151-C HZ-151-PBK HZ-151-Z	HEX BOLT 5/16-18 X 5/8" GRADE 8	Chrome Black Zinc
HZ-152-C HZ-152-PBK HZ-152-Z	HEX BOLT 3/8-24 X 1" GRADE 8	Chrome Black Zinc
HZ-153	HEX BOLT 3/8-24 X 1" GRADE 8	Natural
HZ-155	HEX BOLT M8-25MM GRADE 8	Natural
HZ-201	HEX BOLT 3/8"-16"x2" 1/4" FOR 9999	Natural
HZ-226	ALLEN BOLT SIZE M10-1.5M LENGTH 5"	Natural
HZ-382	ALLEN BOLT SIZE M10-1.5M LENGTH 5"	Natural

Payment Terms

CFR Performance offers the following term options: C.O.D. Credit Card, or Net 30 depends on customer's credit history.

Return Policy

ALL returns must be accompanied by a **Return Good Authorization Number** (RGA) in order for them to be processed. The return form must also be filled out and sent along with your return.

Products must be received within 14 calendar days of the issuance of the RGA. All good merchandise returns are subjected to a 15% Restocking Fee and can only be accepted under brand-new and un-installed condition.

Freight

All orders are shipped freight collect.

Shortages/Claims

Upon receipt of your product, please inspect the packaging to ensure that it has not been damaged. If the packaging or product has been damaged, please contact the shipping carrier immediately to report the damage. Any claims or shortages must be reported to CFR Performance within 7 days after receipt of merchandise.

12 Months Limited Warranty

CFR Performance warrants that all of its products shall be free of defects in materials and/or workmanship. All CFR Performance products come with 12 months limited warranty for the original purchaser accompanied by the original sales receipt. This warranty does not cover any defects caused by improper installation or damage resulting from collision, misuse, negligence or unauthorized alteration.

Important Notice

CFR Performance will not be responsible for any damage caused to property or person, directly or indirectly related to the use of any CFR Performance products.

**Products produced by CFR Performance have been designed for off road competition use only.*

Ads Kits	4-5	Oil Pump Pickups	65
Air Cleaners	10-18	Pedals	104
Air Cleaner Wing Nut	19	Power Steering Bracket Kits	84
Air Conditioning	94	Power Steering Pulleys	79
Air Conditioning Brackets	85	Power Steering Pump	101
Alternators	100	Power Steering Tanks	101
Alternator Brackets	81-83	Pulleys	73-80
Battery Trays	105	Pulley Kits	78
Black Tie	9	Pulley Noses	79
Block Off Plates	99	Radiators	86-90
Bolt Kits		Radiator Caps	92
O Pulleys	77	Radiator Hose Kits	95
O Oil Pan	66	Radiator Mounting Kits	94
O Valve Covers	37	Radiator Overflow Tanks	95
Brackets	81-85	Radiator Support Bars	106
Breathers	35	Radiator Support Panels	106
Column Dress Up Kit	104	Scoops	10
Column Shifter	104	Smog Tube Fitting	19
Cooling Fans	93	Starters	100
Differential Covers	110-15	Steering Wheels	102
Dipsticks	70-72	Steering Wheel Adapters	103
Distributors	98	Steering Wheel Horn Buttons	103
Door & Window Handles	104	Throttle Cable Kits	99
Engine Dress Up Kits	39-41	Throttle Return Spring Kit	99
Fan Shrouds	91-92	Timing Covers	42-43
Flywheel Covers	67	Timing Tabs	43
Fuel Line	99	Transmission Cable Kits	99
Grommets	36	Transmission Coolers	97
Heater Hose Kit	95	Transmission Pans	67-69
Hood Latches	106	Transmission Pan Bolts	69
Hood Pins	105	Transmission Pan Gaskets	69
Headers	107-109	T-Bar Wing Nuts	37
Ignition Coil	98	Valve Covers	20-33
Louvered Style Air Cleaner	19	Valve Cover Gaskets	34
Master Cylinder Covers	100	Valve Cover Hold Down Tabs	37
Mirrors	103	Valve Cover T-Bar Wing Nuts	37
Oil Caps	36	Water Necks	96
Oil Pans	44-63	Water Pumps	97
Oil Pan Gaskets	64	Wire Looms	38
Oil Pan Rails	66		
Oil Plugs	66		

ADS
Accessory Drive Systems

Black-tie
Electro Deposit Primer

It's All About
Character

RFC
Retro Finned Collection

EMC
Evolution Modular Cooling

CFR
PERFORMANCE



Check out the collection of performance engine parts we offer.