



SPC PERFORMANCE®

xAxis™ Sealed Flex Joint



Designed to replace many OE style bushings, SPC's **xAxis™ Sealed Flex Joint** is recommended for use as a bushing replacement when higher performance or increased joint angularity is desired - perfect for race and off-road builders.

More from SPC

Tubular Chassis Components

High quality Rod End Receivers, Spherical Rod Ends, Spherical Bearings and Receivers, High Mis-Alignment Inserts and More!



JounceShocks™

The JounceShock is a patented form of bump shock that will maximize the capacity and performance of your suspension.



Tools and Gauges

The best Flared Hole Dies in the business, our FasTrax™ Camber/Caster/Toe Gauge for portable, hands-free alignment and more!



Suspension Tuning

Get the brand that professionals demand - SPC is the world leader in alignment parts and tools.



Why you want the best sealed flex joint in your build:

Features

- Sealed joint retains grease and excludes contaminants
- Highly polished electroless-nickel finish on ball maximizes durability
- Up to 45° total angularity for high mis-alignment requirements
- Common sizes that builders and racers need

Benefits

- Reduced compliance and deflection vs rubber and poly joints
- Improved durability vs spherical bearings and poly bushings
- Increased angularity vs rubber and poly bushings
- Engineered to be a direct fit for many popular street/race or HD off-road applications



Get xAxis in your build -

See the next page for sizes, xAxis Rod End Receivers, Weld-In Receivers, and xAxis custom Press Tool Adapters.

Build your
Series
Off-Road

xAxis Sealed Flex Joint

SPC's **xAxis™** is recommended for use when higher performance or joint angularity is desired. Available in a wide variety of sizes xAxis joints can be easily retrofitted into many stock configurations or can be the perfect fit when starting out a custom project.

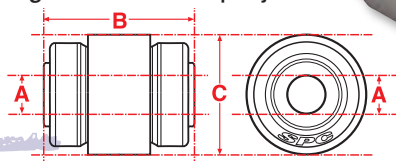
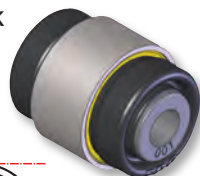

Part No.	Bolt Size (A)	Width (B)	Outer Dia (C)	Press Adapter
15605	.375"	1.500"	1.250"	29607
15607	.500"	2.000"	1.750"	29608
15609	.625"	2.500"	2.000"	29610
15611	.750"	3.250"	2.500"	29612
15613	10mm	2.000"	1.8125"	29609
15615	12mm	2.000"	1.8125"	29609
15616	14mm	2.375"	1.8125"	29609
15617	14mm	1.625"	38.5mm	29605
Build your own JK track bar - this xAxis' bolt hole and width are designed for JK track bar brackets				
15619	14mm	2.625"	2.250"	29611
15620	16mm .625"	2.625"	38.5mm	29605
Designed to replace joints in most aftermarket solid axle Jeep lower control arms, inc. SPC 13415 & 13425				
15623	12mm	40mm	40mm	29606
15625	10mm	40mm	1.750"	29608
15627	12mm	42mm	40.2mm	29606
15629	12mm	45mm	40mm	29606
15631	12mm	47mm	40mm	29606
15633	12mm	50mm	40mm	29606
15635	12mm	50mm	40.2mm	29606
15637	12mm	57mm	40mm	29606
15639	14mm	40mm	40mm	29606
15643	12mm	44.5mm	40mm	29606

Bushing Press Adapters are designed for quick, easy removal of the old bushings and installation of SPC's **xAxis** joints.



xAxis Rod End Ball Joint

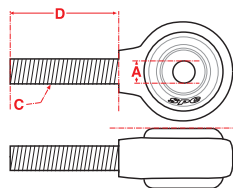

xAxis™ Rod End Ball Joints are the way to get all the benefits of xAxis Sealed Flex

Joints into your project. Includes xAxis, forged receiver, jam nut and snap ring.



Part # Right Thread	Part # Left Thread	Bolt Dia (A)	Width (B)	Thread (C)	Thread Length (D)	Suggested Applications
15730	15731	10mm - 3/8"	2.000"	3/4" - 16	3.2"	Aftermarket Jeep TJ upper control arms
15732	15733	12mm	2.000"	3/4" - 16	3.2"	Aftermarket Jeep JK front upper control arms
15734	15735	14mm - 9/16"	2.375"	3/4" - 16	3.2"	Aftermarket Jeep JK rear upper control arms
15736	15737	5/8"	2.625"	1" - 14	3.2"	Aftermarket Jeep TJ and JK lower control arms modified for 5/8"-16mm bracket bolts
15738	15739	5/8"	2.625"	1 1/4" - 12	3.2"	Heavy duty aftermarket Jeep TJ and JK lower control arms modified for 5/8"-16mm bracket bolts
15740	15741	14mm - 9/16"	2.625"	1" - 14	3.2"	Aftermarket Jeep TJ and JK lower control arms
15742	15743	14mm - 9/16"	2.625"	1 1/4" - 12	3.2"	TJ and JK lower control arms
15744	15745	3/8"	1.5"	1/2" - 20	2.9"	
15746	15747	1/2"	2.0"	3/4" - 16	3.0"	
15748	15749	5/8"	2.5"	1 1/4" - 12	2.8"	
15750	15751	3/4"	3.250"	1-1/4" - 12	3.2"	
15752	15753	12mm	40mm	3/4" - 16	2.9"	
15754	15755	12mm	40mm	M18x1.5	2.9"	
15764	15765	12mm	45mm	3/4" - 16	2.9"	
15766	15767	12mm	45mm	M18x1.5	2.9"	
15768	15769	12mm	47mm	3/4" - 16	2.9"	
15770	15771	12mm	47mm	M18x1.5	2.9"	
15772	15773	12mm	50mm	3/4" - 16	2.9"	
15774	15775	12mm	50mm	M18x1.5	2.9"	
15780	15781	12mm	57mm	3/4" - 16	2.9"	
15782	15783	12mm	57mm	M18x1.5	2.9"	
15784	15785	14mm	40mm	3/4" - 16	2.9"	
15786	15787	14mm	40mm	M18x1.5	2.9"	
15792	15793	12mm	44.5mm	3/4" - 16	2.9"	
15794	15795	12mm	44.5mm	M18x1.5	2.9"	

Weld-In Receivers with 2 Snap Rings

Use this weld in receiver to create your own control arm or chassis mount with an SPC **xAxis™** sealed flex joint. Designed with optimal press fit for the xAxis these receivers include two snap rings for retention and an access window for easy snap ring removal.

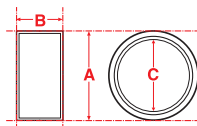

Part No.	O. D. (A)	Width (B)	I. D. (C)	Press Adapter
15520	1.50"	0.82"	1.25"	29607
15521	2.25"	1.12"	1.75"	29608
15522	2.50"	1.25"	2.00"	29610
15523	3.00"	1.56"	2.50"	29612
15524	2.25"	1.07"	1.8125"	29609
15525	2.75"	1.17"	2.25"	29611
15526	47.6mm	27.3mm	40mm	29606



Tubular Chassis Components

Chassis Components

ROD END RECEIVERS

Material Spec: 4140 N Chromoly Steel Includes Grade 8 bolt, metal locknut and 2 AN washers

Welds into stock tubing sizes.

Cinch bolt maintains high clamping force.



ROUND ROD END RECEIVERS

RH Thread Part #	15120	15110	15100	15090	15080	15092	15082
LH Thread Part #	15125	15115	15105	15095	15085	15097	15087
Thread Size (A)	1/2" - 20	5/8" - 18	3/4" - 16	7/8" - 14	1 1/4" - 12	7/8" - 14	1 1/4" - 12
Outside Dia. (B)	.745"	.870"	1.120"	1.370"	1.870"	1.260"	1.760"
Thread Length (C)	1.2"	1.3"	1.4"	1.5"	1.7"	1.5"	1.7"
Overall Length (D)	1.813"	1.938"	2.125"	2.250"	2.563"	2.250"	2.563"
Nominal Tube Size	.875" OD	1.000" OD	1.250" OD	1.500" OD	2.000" OD	1.500" OD	2.000" OD
Recommended Tube Wall Thickness	0.065"*	0.065"*	0.065"*	0.065"*	0.065"*	0.120"**	0.120"**

* .065 receivers may be turned down to fit other tubing sizes ** We recommend that .120 receivers not be turned down

CAD Models Available for Builders



SQUARE ROD END RECEIVERS

RH Thread Part #	15170	15160	15150	15140	15130
LH Thread Part #	N/A	N/A	N/A	N/A	N/A
Thread Size (A)	1/2" - 20	5/8" - 18	3/4" - 16	7/8" - 14	1 1/4" - 12
Width (B)	0.688"	0.875"	1.063"	1.250"	1.813"
Thread Length (C)	1.2"	1.3"	1.4"	1.5"	1.7"
Overall Length (D)	1.813"	1.938"	2.125"	2.250"	2.563"

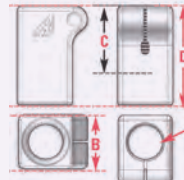

3 PIECE SPHERICAL ROD ENDS

RH Thread Part #	15474	15476	15478	15480	15482
LH Thread Part #	15475	15477	15479	15481	15483
Bore	.50 Bore	.625 Bore	.750 Bore	.875 Bore	1.00 Bore
Thread Size	1/2"-20	5/8"-18	3/4"-16	7/8"-14	1 1/4"-12



SPHERICAL BEARING RECEIVERS

Material Spec: 4140 N Chromoly Steel Includes Retaining Ring

Part #	15065	15060	15055	15050	15045	15040	15042
Bearing Dia. (A)	0.8125"	1.0000"	1.1875"	1.3750"	1.6250"	2.1250"	2.7500"
Bear. Race Width (B)	0.4060"	0.5050"	0.5670"	0.6300"	0.7550"	1.0050"	1.099"
Receiver OD (C)	1.063"	1.250"	1.483"	1.625"	1.925"	2.500"	3.250"
Receiver Width (D)	0.58"	0.71"	0.84"	0.92"	1.06"	1.41"	1.527"
Bearing Offset (E)	0.0170"	0.0125"	0.0265"	0.0150"	0.0025"	0.0025"	0.012"

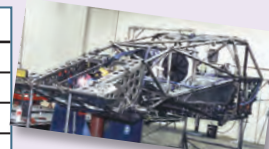

SPHERICAL BEARINGS

With Teflon Liners

Part #	15465	15460	15455	15450	15445	15440	15442
Corresponds to Receiver Number	15065	15060	15055	15050	15045	15040	15042
Inside Diameter	0.375"	.500"	.625"	.750"	.875"	1.000"	1.500"
Outside Diameter	0.8125"	1.0000"	1.1875"	1.3750"	1.6250"	2.1250"	2.7500"

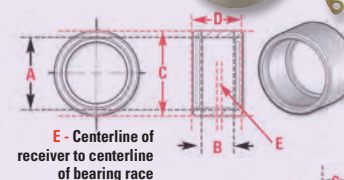

HIGH MIS-ALIGNMENT INSERTS (Pair)

Material Spec: Hardened Stainless Steel

Part #	15032	15028	15015	15020	15018	15010	15012	15024	15022
Shoulder OD (A)	0.500"	0.625"	0.750"	0.875"	0.875"	1.000"	1.000"	1.500"	1.500"
Internal Dia. (B)	0.375"	0.500"	0.500"	0.500"	0.625"	0.625"	0.750"	0.625"	0.750"
Shoulder Length (C)	0.300"	0.345"	0.433"	0.433"	0.385"	0.675"	0.675"	0.608"	0.683"
Part Length (D)	0.730"	0.720"	0.875"	0.875"	0.950"	1.080"	1.080"	1.790"	1.790"
Stack Length (E)	1.500"	1.500"	1.750"	1.750"	2.000"	2.160"	2.185"	3.600"	3.6250"
Mis-Alignment Angle	21 Deg.	24 Deg.	30 Deg.	30 Deg.	30 Deg.	30 Deg.	28 Deg.	29 Deg.	30 Deg.

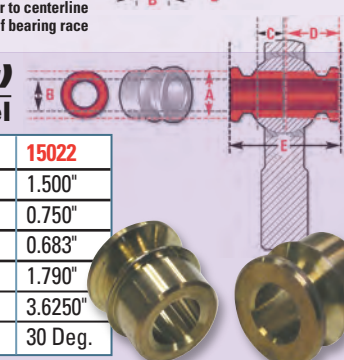

JounceShocks™

The JounceShock is a patented form of bump shock that will maximize the capacity and performance of your suspension. The nitrogen charged secondary shock adds additional compression damping and controlled rebound to your vehicle's system. The result is: exponential suspension bottoming protection, increased stability and handling at all speeds, and reduced stress and loads for both the vehicle and driver.

Benefits

- Eliminate suspension bottoming
- Increase stability and improve handling at all speeds
- Enhance rock crawling ability
- Improve towing stability and load capacity

Double your suspension capacity

- Off-Road Racing
- Rock Racing
- Rock Crawling
- Recreational Off-Road
- Lifted & Stock Trucks
- Fleet Vehicles



25710 1.5" TRAVEL JOUNCESHOCK

6" extended unit is great for tight spaces with 1:1, up to 3:1 motion ratios

25715 3.0" TRAVEL JOUNCESHOCK

9" extended unit is ideal for 1:1 motion ratios

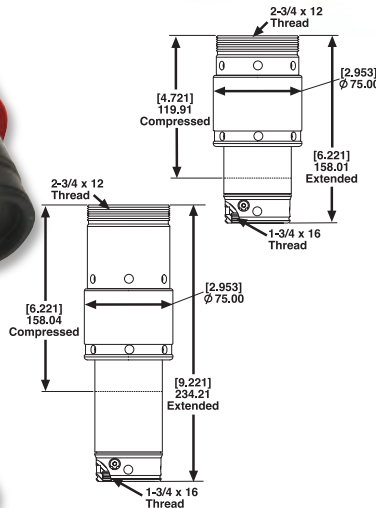

25710

UNIVERSAL 1.5" TRAVEL UNIT

- 2-3/8" Bore
- Adjustable nitrogen pressure and oil fill
- Adjustable Compression & Rebound
- 6.22" Extended
- 4.72" Compressed

25715

UNIVERSAL 3.0" TRAVEL UNIT

- 2-3/8" Bore
- Adjustable nitrogen pressure and oil fill
- Adjustable Compression & Rebound
- 9.22" Extended
- 6.22" Compressed

JOUNCESHOCK REBUILD KITS

The seals, O-Rings, wear bands, and valve pieces needed to rebuild your JounceShocks. Kits include the Shock Valve Extension (#25515) for recharging your JounceShock.

25712

Single (1) rebuild kit

25713

Four (4) rebuild kits



25515 VALVE EXTENSION

Required to adjust nitrogen pressure in JounceShocks. Included with our Rebuild Kits (left - #25712 and #25713).



25520 PIN WRENCH SET

This versatile pin wrench set of two double ended tools is specially engineered to cover 7 different diameters: 2", 2-3/16", 2-1/4", 2-3/4", 2-7/8", 3", and 3-1/4". These sizes are perfect for working with JounceShock and JounceShock End Mounts. This economical pin wrench set would be an excellent addition to any builder's tool box.



SHAFT BOOT

These boots will keep 'stone blast' caused by rocks and dirt from damaging your JounceShocks and causing seal failure.

25701

Protective Boot - 1.5" Travel JounceShock (#25710)

25702

Protective Boot - 3.0" Travel JounceShock (#25715)



BODY BOOT

25505

This Urethane Guide will protect your JounceShock from contact with suspension parts. Perfect when using JounceShocks mounted within a coil spring.



Upper Mounts

15° FLEX MOUNT 25501

This mount can be welded or bolted to your mounting point, giving you 7.5° of articulation in any direction and will most often be used with the Cupped Foot and Domed Target kits (part nos. 25601, 25613).

FIXED MOUNT 25505

The Fixed Mount can be welded to your existing structure. It provides a simple attachment point for your JounceShock and will most often be used with the Domed Foot on the shaft end of the shock (part nos. 25602, 25604, 25605).

CONCENTRIC CARRIER/ BOLT ON MOUNT 25508

The Concentric Carrier/Bolt on Mount can be sandwiched above your spring upper seat or bolted to the bottom of a frame. Plate can be trimmed as needed to bolt or weld to your frame.

FRAME SIDE MOUNT 25530

This universal Mount provides a versatile bolt/ welded on option to mount your JounceShock in a fixed position, such as the side of your frame rail (trim-to-fit).

Cylinder end female thread mount
Material: Carbon Steel



Trim top and/or bottom to fit



Lower Ends

CUPPED FOOT & DOMED TARGET

The Cupped Foot and bolt/welded on Domed Target are typically used with the Flex Mount to assure ideal JounceShock alignment through your vehicle's suspension travel.

Shaft end male thread - cupped foot

25601 Delrin Cup Foot & Carbon Steel Target

25613 90A Rubber Cupped Foot (Quiet Ride) & Carbon Steel Target

DOMED FOOT

The Domed Foot screws directly into the shaft of the JounceShock. The traditional bump shock end is most often used in applications with some 'scrub' (lateral motion) on a Target Plate. It can also be used in conjunction with the Shaft Extension Kit (part no. 25603). Your choice of materials.

25602 Delrin Mid-range ride, long life

25604 UHMW Harsher ride, extremely long life

25605 90A Rubber Quiet Ride, short life

SHAFT EXTENSION KIT 25505

For lifted applications, this a cut to length adapter will add 1" to 7" inches to the shaft of your JounceShock allowing you to fine tune contact points as well as a smaller dimension to stab at a target (sold singly).



JounceShocks

Complete JounceShock Systems

We'll fit you!

We have pre-made systems for some of the most popular off road vehicles in the market. With these complete systems it is easy to get the benefits of a JounceShock system into your truck. Systems include everything you need from custom mounts to the nuts and bolts and detailed instructions.



	FROM	TO	DRIVE	FRONT	REAR	TOTAL
FORD						
F150/Raptor	2004	2014	4x4, 4x2		25824	
F250, F350 Super Duty	2005	2010	4x4	25832	25834	25830
HUMMER						
H3	2006	2010	4x4, 4x2	25872	25874	25870
JEEP						
Wrangler (JK)	2007	2013	4x4, 4x2	25732	25734	25730
NISSAN						
Frontier	2005	2015	4x4, 4x2	25792	25794	25790
Navara D40	2005	2015	4x4, 4x2	25792	25794	25790
Pathfinder	2005	2012	4x4, 4x2	25792		
Xterra	2005	2015	4x4, 4x2	25792		

	FROM	TO	DRIVE	FRONT	REAR	TOTAL
TOYOTA/LEXUS						
4Runner	2003	2009	4x4, 4x2	25762	25784	25780
4Runner	1996	2002	4x4, 4x2	25742	25746	
FJ Cruiser	2007	2009	4X4	25762	25784	25780
GX470	2003	2009	4X4	25762	25784	25780
Hilux MK6	2005	2015	4x4, 4x2	25762	25764	25760
Prado 120 Series Land Cruiser	2002	2009	4x4, 4x2	25762	25784	25780
Prado 90 Series Land Cruiser	1996	2002	4x4, 4x2	25742	25746	
Tacoma 4x4/Pre Runner	2005	2015	4x4, 4x2	25762	25764	25760
Tacoma	1996	2004	4x4	25742	25744	25740

Tools and Gauges

15810
15815

FLARED HOLE DIES

Often called "dimple dies," Flared Hole Dies are used in sheet-metal fabrications to provide rigidity and strength to flat panels. Due to the resulting high

strength-to-weight ratio flared holes are found in many aircraft and race vehicle designs.

Beginning with comprehensive finite element analysis supported by extensive prototype testing, our light weight Flared Hole Dies are engineered to provide the optimum combination of performance attributes:

- Eliminate edge tearing when used on chromoly, even with edges hardened by laser cutting methods
- Will flare holes in chromoly up to .090" thick or flare holes in up to .125" mild steel
- Manufactured from high quality hardened tool steel
- Available for hole diameters from 3/4" to 4"

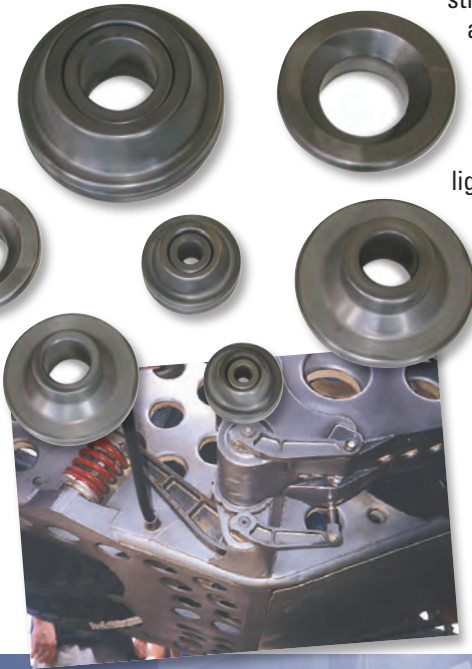

Part #	Dia.	Part #	Dia
15835	.75"	15865	2.5"
15840	1.0"	15870	3.0"
15850	1.5"	15875	3.5"
15860	2.0"	15880	4.0"

Set #	Dies Included
15810	15835, 15840, 15850, 15860, 15865
15815	15870, 15875, 15880

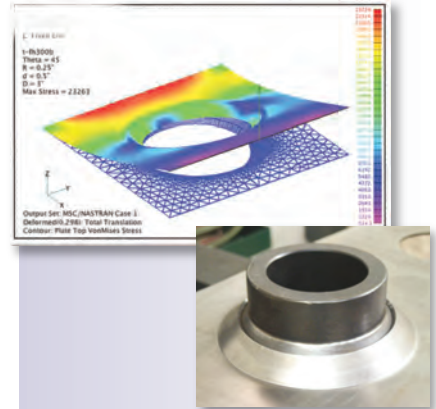

FASTRAX™ CAMBER / CASTER GAUGE

Portable, hands-free alignment can be done quickly and easily with the *FasTrax™ Adjustable Camber/Caster Gauge*. This tool will help you fine tune your alignment for optimal tracking and handling while minimizing alignment expense.

- Includes gauge and wheel mount.
- Saves time and tires.
- Displays Camber $\pm 4^\circ$ / Caster -4° to $+12^\circ$.
- Accurate, rugged and easy-to-use.



91025

91025 Off-Road - Fits Wheels 13" to 17"
Align off-road wheels - tire sizes up to 44".
Includes longer toe arms, bungee cord & tape measure.

91000 Standard - Fits wheels 13" to 17"
Optional Toe Adapter Kit (91100) sold below.

91100 Optional Toe Adapter Kit
Simply lower the toe arms and insert tape measure into slot. Then measure to opposite tire reference point for accurate and fast toe readings. Includes 2 arms and reinforcement blocks that install easily onto the 91000.



91000

91100

64225



MAGNETIC ANGLE GAUGE

This angle gauge is an easy, accurate way to measure frame and drive shaft angles. An ideal tool to ensure angles are still within specification for raised and lowered vehicles. *Alignment equipment manufacturers are using frame angle input with their software for completing caster specifications.*

Jeep JK Suspension Arm Series

13410

Front Adjustment range:

Caster and Pinion $\pm 3.0^\circ$

Installation time: .5 hr/side

Required: 2 per axle

13415

Front Replacement Part

Installation time: .5 hr/side

Required: 2 per axle

13420

Rear Adjustment range:

Pinion $\pm 3.0^\circ$

Installation time: .5 hr/side

Required: 2 per axle

13425

Rear Replacement Part

Installation time: .5 hr/side

Required: 2 per axle

APPLICATIONS

Jeep: 2007 & Up Wrangler (JK)



SPC knows JK - Look for all of our JK Products - see next page:

23510 Pin Joints

23605 Tie Rod Adjuster Sleeves

26012 Camber Shims
& 26014

82390 Rear Caster/Pinion
Adjusting Bolts

These direct-fit control arms add strength, and articulation flexibility to your stock-height or 'lifted' Wrangler. They feature SPC's xAxis™ sealed flex joints to provide bind-free 'twist' between the frame and axle during articulation and O.E. 'Clevite' bushings for long service life and reduced N.V.H. Main tubes are D.O.M steel to provide strength for large tires and aggressive gearing. Bent arms provide additional clearance for taller/wider tires.

JEEP JK FRONT ADJ. UPPER CONTROL ARM W/XAXIS

13410

These direct-fit front upper control arms add strength, on-car adjustability and articulation flexibility to your stock-height or 'lifted' suspension Wrangler. They feature SPC's xAxis sealed flex joints mounted in forged rings at the frame ends to provide bind-free 'twist' between the frame and axle during off-road articulation. The dual-threaded adjuster and jam nuts make caster/pinion angle adjustments quick and easy without the need to disconnect the arms or mess with cams and slotted hole knock-outs. Main tube is DOM steel for 'overkill' strength to handle large tires, low gearing, and big horsepower.



JEEP JK FRONT LOWER CONTROL ARM W/XAXIS

13415

These direct-fit, stock-length front lower control arms add strength, and articulation flexibility for your stock-height or 'lifted' suspension Wrangler. They feature SPC's xAxis sealed flex joints to provide bind-free 'twist' between the frame and axle during off-road articulation. The main tube is 3/16" wall round DOM steel to provide strength and a knobby-tread-friendly shape to handle large tires, low gearing, and big horsepower.



JEEP JK REAR ADJ. UPPER CONTROL ARM W/XAXIS

13420

These direct-fit rear upper control arms add strength, on-car adjustability and articulation flexibility of your stock-height or 'lifted' suspension Wrangler. They feature SPC's xAxis sealed flex joints mounted in forged rings on the axle ends to provide bind-free 'twist' between the frame and axle during off-road articulation. The dual-threaded adjuster and jam nuts make rear pinion angle adjustments quick and easy without the need to disconnect the arms. Main tube is 3/16" wall DOM steel for 'overkill' strength to handle large tires, low gearing, and big horsepower.

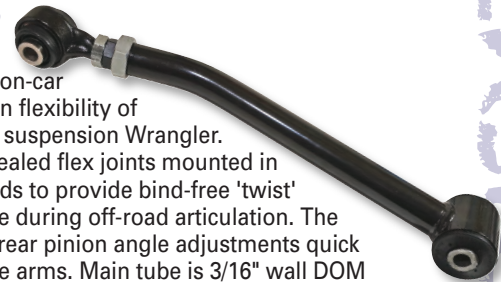

JEEP JK REAR LOWER CONTROL ARM W/XAXIS

13425

These direct-fit, stock-length rear lower control arms add strength and articulation flexibility to your stock-height or 'lifted' Wrangler. They feature SPC's xAxis sealed flex joints at one end to provide bind-free 'twist' between the frame and axle during off-road articulation. The main tube is 3/16" wall round DOM steel to provide strength to handle large tires, low gearing, and big horsepower.



15620 xAxis™
for aftermarket
Jeep Control Arms

Designed to replace the common 2-1/4" dia x 2-5/8" wide bushings in most aftermarket solid axle Jeep lower control arms, (including SPC's 13415 and 13425 JK control arms) the 15620 xAxis is recommended for heavy recreational off-road or competition use. While the OD and width of this xAxis are standard, it accommodates a 5/8" or 16mm bolt per requests from racers and rock crawlers.

Off-Road Suspension

Jeep/Dodge Suspension Tuning

JEEP/DODGE PIN JOINTS

These offset pin joints replace the upper pin joints on Jeep and Dodges. They come in 1/2° increments and provide for independent wheel caster and/or camber changes up to 2.0°, depending on application. joints. * **Note: 23800 is an OEM Replacement Pin Joint with no change in camber or caster.**



Suggested Tools

- 23510 - 23540
- 23580 - Press Sleeves; 72509 - Ball joint press
- 23710 - 23730 & 23800 - 23830
- 23780 - Press Sleeves; 72509 - Ball joint press
- 23850 - 23854
- 88360 - Pin Adjusting Wrench

Installation time: 1.0 hr/side Required: 1 per wheel

23510	Cam/Cas ±.50°	23800	Cam/Cas 0.0°
23520	Cam/Cas ±1.00°	23810	Cam/Cas ±.50°
23530	Cam/Cas ±1.50°	23820	Cam/Cas ±1.00°
23540	Cam/Cas ±2.00°	23830	Cam/Cas ±1.50°

APPLICATIONS

Dodge 4WD:
1994 - 01 1500 Ram; 1994 - 99 2500 Ram
Jeep RWD/4WD:
1984 - 01 Cherokee; 1986 - 92 Comanche
1993 - 04 Grand Cherokee
1984 - 93 Wagoneer; 1987 & Up Wrangler

APPLICATIONS

Dodge RWD:
2003 & Up 3500 Ram w/mono beam
Dodge 4WD:
2006 - 08 1500 Ram Mega Cab
2003 & Up 2500, 3500 Ram

23850*	Camber 0.0°	23710	Cam/Cas ±.50°
23852	Camber ±.50°	23720	Cam/Cas ±1.00°
23854	Camber ±1.00°	23730	Cam/Cas ±1.50°

APPLICATIONS

Dodge RWD/4WD: 2008 & Up 4500, 5500
Sterling Bullet RWD/4WD: 2008 - 10 45, 55

APPLICATIONS

Dodge 4WD:
2000 - 02 2500 Ram, 3500 Ram
Dodge RWD:
2000 - 02 3500 Ram w/monobeam

DODGE 1500 ADJ. BALL JOINT

Lifted or lowered, factory cams don't give enough adjustment range on the Dodge Ram 1500 series of trucks. Simply replace the ball joint in the stock upper control arm to get ±2.25° caster, camber, or a split and then dial in final adjustments with the factory cams.



23940 Front Adjustment range:
Camber ±2.25° OR Caster ±2.25°

Installation time: .6 hr/side Req.: 1 per wheel

APPLICATIONS

Dodge/Ram RWD/4WD:
2006 & Up 1500 Ram (Exc. Mega Cab)

TIE ROD ADJ. SLEEVES

This adjustable hex shaped sleeve replaces the round tie rod sleeve on Jeep and Dodge Rams to assure ease of adjustment without slippage. Recommended when existing sleeve is damaged or when replacing a tie rod end.



Front Replacement Part

Installation time: .5 hr/side Required: 1 per wheel

APPLICATIONS

23610 <i>Manufactured before 11/4/13</i>	23605 Jeep: 2007 & Up Wrangler (JK)
Dodge: 2014 Ram 2500; 2013 - 14 Ram 3500	23615 <i>Manufactured after 11/4/13</i>
	Dodge: 2014 & Up Ram 2500 2014 & Up Ram 3500

JEEP PINION/CASTER BOLTS

Correct various alignment angles on many Jeep platforms with these versatile adjustable cam bolts.



82370 Rear Adjustment range:
Pinion Angle ±2.00°

Install time: .3 hr/axle
Required: 1 kit per axle

APPLICATIONS

Jeep RWD/4WD:
1997 - 06 Wrangler (TJ)

82380 & 82390 Front Adjustment range:
Caster ±1.50°/Pinion Angle ±1.50°

Install time: .4 hr/axle Req.: 1 kit per axle

82380 APPLICATIONS

Jeep 4WD: 1997 - 06 Wrangler (TJ)
Dodge 4WD: *With 36mm cams* 1994 - 99 1500 Ram

82390 APPLICATIONS

Jeep RWD/4WD: 2007 & Up Wrangler (JK)



JEEP CASTER SHIMS

These shims provide positive caster changes on downsized Jeeps by installing them between the lower control arm and the frame bracket.

Stackable for larger changes. **Six shims per box.**

47240 - 1/32"	47241 - 1/16"
47242 - 1/8"	

Adjustment range: 1/32" to 1/8"
Installation time: .3 hr/side

APPLICATIONS

Jeep: 1984 - 01 Cherokee; 1985 - 92 Comanche
1993 - 04 Grand Cherokee; 1984 - 93 Wagoneer



JEEP CAMBER SHIMS

Change camber +0.5° or +1.0° on popular Jeep models by installing this shim between the hub and steering knuckle. A caliper shim is also included for use on WJ, KJ, and JK models. These durable high-strength nylon shims provide a faster option for correcting negative camber issues.

26012 Front Adj. range:	Camber +.50°	Install time: .3 hr/side
26014 Front Adj. range:	Camber +1.0°	Req.: 1 per wheel

APPLICATIONS

Jeep 4WD: 1984 - 01 Cherokee XJ
1993 - 04 Grand Cherokee ZJ/WJ;
1987 - 06 Wrangler YJ/TJ;
1984 - 90 Wagoneer XJ

Jeep RWD: 1994 - 01 Cherokee XJ
Jeep FWD/4WD: 2002 - 07 Liberty KJ
Jeep RWD/4WD: 1986 - 92 Comanche MJ
2007 & Up Wrangler JK

Toyota Suspension Tuning

Off-Road Suspension

Front Adjustment range: Cam./Cas. $\pm 1.50^\circ$
 Installation time: .3 hr/side Req.: 1 per wheel

25425 APPLICATIONS

Note: Plastic Sleeves not necessary with this kit.
Toyota 4WD: 1986 - 95 Runner; Tacoma
 1986 - 94 Truck; 1993 - 98 T100

25430 APPLICATIONS

Toyota RWD: 1998 - 04 Tacoma PreRunner
Toyota 4WD: 1996 - 04 Tacoma
Toyota RWD/4WD: 1996 - 02 4-Runner

25435 APPLICATIONS

Toyota RWD: 2005 & Up Tacoma PreRunner
Toyota 4WD: 2005 & Up Tacoma
Toyota RWD/4WD: 2007 - 09 FJ Cruiser; 2003 - 09 4Runner

25440 APPLICATIONS

Toyota RWD/4WD: 2010 - 14 FJ Cruiser; 2010 & Up 4Runner

25445 APPLICATIONS

Toyota RWD/4WD: 2001 - 07 Sequoia; 1999 - 06 Tundra

Front Adjustment range:
 Camber $\pm 2.00^\circ$ Caster 0.0° to $+4.00^\circ$
 Installation time: .8 hr/side Required: 1 per axle

25455 APPLICATIONS

(Note: Caster Range -1.0° to $+3.0^\circ$)
Toyota 4WD: 1998 - 07 Landcruiser 100 Series

25460 APPLICATIONS

Toyota RWD: 1998 - 04 Tacoma PreRunner
Toyota 4WD: 1995 - 04 Tacoma
Toyota RWD/4WD: 1996 - 02 4Runner

25465 APPLICATIONS

Toyota 4WD: 2008 & Up Landcruiser 200 Series

25470 APPLICATIONS

Toyota RWD: 2005 & Up Tacoma PreRunner
Toyota 4WD: 2005 & Up Tacoma

25480 APPLICATIONS

Toyota RWD/4WD: 2007 - 14 FJ Cruiser; 2003 & Up 4Runner

25485 APPLICATIONS

Toyota RWD/4WD: 2001 - 07 Sequoia; 1999 - 06 Tundra

25490 APPLICATIONS

Toyota RWD/4WD: 2007 & Up Tundra; 2008 & Up Sequoia

These arms feature our SpecRide™ bushings for a quieter, OEM style ride.

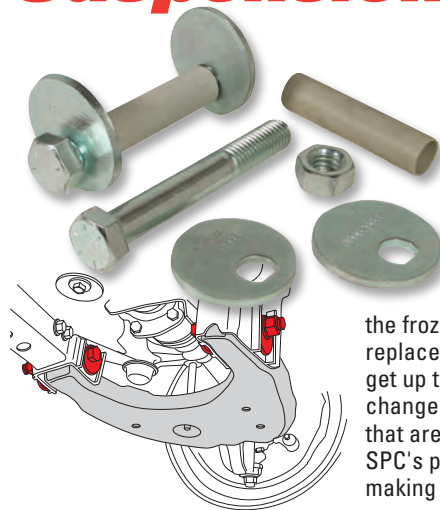

TOYOTA CAM BOLT KIT

This Cam Bolt Kit is a replacement kit for the OE adjusters. The OE bolts on Toyota trucks and SUVs are frequently "frozen" and do not allow for adjustment. Remove the frozen bolt assembly and replace it with an SPC cam kit to get up to $\pm 1.5^\circ$ camber and caster change. OE adjuster assemblies that are corroded may require SPC's press tool 40915 for removal, making the job quick and easy.

40915 - TOYOTA CAM EXTRACTOR

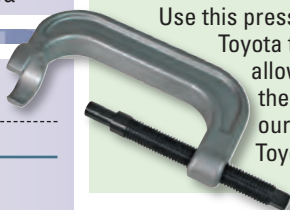

Use this press tool to remove stuck OE cam sleeves from Toyota trucks. The extended length forcing screw allows you to remove the sleeve without removing the steering rack. Recommend when installing our 25430, 25435, 25440 and 25445 replacement Toyota cams (above).

RWD & 4WD TOYOTA FRONT UPPER ARMS (PR)



Many Toyota trucks and SUVs run out of factory adjustment when you install lift kits. With our patented design this upper control arm provides an additional $\pm 2^\circ$ of camber and 0° to $+4^\circ$ of caster change. Built with an OE style ball joint and new SpecRide™ bushings, this arm is designed to correct alignment angles while maintaining factory ride quality. The hybrid tubular and forged steel design is tough enough to race on or off-road. These

Patent No. US 7,513,514 B

remove and replace arms are available in pairs for lifted and off-road applications. **Note: Arms are packaged with all parts needed for installation - your arm may be different than pictured.**

Rear Replacement Part

Installation time: .3 hr/side
 Required: 1 per axle

25950 APPLICATIONS

Toyota: 2003 - 14 4Runner
 2007 - 14 FJ Cruiser

25955 APPLICATIONS

Toyota: 1998 - 07 Landcruiser (100 Series)

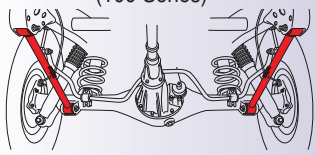

25950

25955

Offset
 Bearing Kits



TOYOTA REAR LOWER CONTROL ARMS (PR)

This pair of rear lower control arms are direct replacements for weak or bent factory units. Made of 3/16" wall DOM tube, they are more than 2x stronger than the OEM arms! They are equipped with a rubber bushing in one end for isolation of road noise and an xAxis™ sealed flex joints in the other end for superior flexibility off road. Whether you are replacing damaged OE parts or upgrading for off-road use, these are the arms for you. Need articulation or alignment changes in the front? Check out our front adjustable upper control arms (above).

THERE'S LOTS MORE!!!

Go online or check our Sourcebook for more Toyota Off-Road Solutions

Chevy/GMC Suspension Tuning

GM ADJUSTABLE BALL JOINT

These heavy duty offset ball joints have a built in 3 degree offset which can be clocked to affect camber, caster, or both. They are ideal for vehicles which cannot be aligned properly with the factory cam bolts due to installation of a lift or leveling kit. As an additional benefit, they also raise the outer end of the upper control arm, which increases clearance between the arm and the droop travel stops on the frame. This restores droop travel on trucks with leveling kits, and eliminates noise vibration harshness caused by arm to frame contact.

Note: Due to strength limitations of the factory upper control arm, this ball joint should not be used on trucks with tires larger than 33" unless using a "tall knuckle" lift kit.



23960 Front Adjustment range:
Camber $\pm 3.00^\circ$ / Caster $\pm 3.00^\circ$

Installation time: .6 hr/side
Required: 1 per wheel

APPLICATIONS

Chevy/GMC RWD/4WD: (With 8 Lug Wheels)
2001 - 06 1500 HD Crew Cab
1999 - 10 2500, 3500 Silverado, Sierra
2002 - 06 Avalanche 2500
2000 & Up Suburban 2500
Hummer 4WD: 2002 - 09 H2

GM HEAVY DUTY CAM/CAS KIT

These heavy duty cam bolts replace the upper control arm mounting bolts. This kit has the added convenience of slip-on cams which makes installation easier. Remove the O.E. Bolts and replace them with these cams, rotating to provide camber and caster adjustment. Use 74910 punch to remove the O.E. slugs and elongate the holes.

74910 - KNOCK OUT PUNCH

A necessary tool for removing the alignment inserts on the upper control arm alignment brackets without damaging the bracket. Includes a center Punch for the older GM vehicles and newer Jeep JKs and an offset punch for GM's newest models.



83790 (2) / 87400 (4)

Front Adj.range: Cam/Cas $\pm 2.00^\circ$

Installation time: .5 hr/side
Required: **83790** 1 per wheel
87400 1 per axle

APPLICATIONS

Chevy/GMC AWD: 1990 - 05 Astro/Safari Van
4WD: 1988 - 00 1500, 2500, 3500
(99-00 Classic Only)
RWD/4WD: 1992 - 94 Blazer (full size)
1988 - 91 Jimmy (full size)
1992 - 99 Suburban
1995 - 99 Tahoe

GM ALIGNMENT CAM LOCK PLATES **86320, 86321**

This lock plate is designed to keep the front alignment angles in position by replacing the existing slotted cam. The 86320 is for newer models of GMC's 1500, 2500 and 3500 vehicles and the 86321 is for 2011 and up HD 2500, 3500 and 4500 along with the 2015 and up Colorado.



86320 & 86321 Locks in OE Adjustment

Installation time: .3 hr/side Req.: 1 per wheel

APPLICATIONS

86320 (Cam Lock Plates) & 86325 (Replacement Pins)
Chevrolet/GMC RWD/4WD: 1999 & Up 1500 & 1500HD Crew Cab; 1999 - 10 2500, 3500; 2002 - 13 Avalanche 1500 2500; 2004 - 12 Canyon & Colorado; 2000 & Up Suburban, Tahoe, Yukon, Yukon XL (1500, 2500)
Hummer AWD: 2002 - 09 H2; 2006 - 10 H3, H3T

86321 (Cam Lock Plates) & 86326 (Replacement Pins)

Upper Arm: **Chevrolet/GMC RWD/4WD:** 2011 & Up 2500HD, 3500HD, 4500
Lower Arm: **Chevrolet RWD/4WD:** 2015 & Up Colorado
GMC RWD/4WD: 2015 & Up Canyon

GM ALIGNMENT PINS **86325, 86326**

These pins replace the alignment pins in the GM vehicles listed. The pins make it easier to align the vehicle and often become bent or crushed and need to be replaced. **Includes 8 pins.**



86375 & 86376 Alignment Plates and Cams

Front Adjustment range: Camber / Caster $\pm 1.50^\circ$

Installation time: .3 hr/side Req.: 1 per wheel

APPLICATIONS

86375 (Alignment) & 86325 (Replacement Pins)
Chevrolet/GMC RWD/4WD: 1999 & Up 1500 & HD Crew Cab; 1999 - 10 2500, 3500; 2002 - 13 Avalanche 1500, 2500; 2004 - 12 Canyon & Colorado
2000 & Up Suburban, Tahoe, Yukon, Yukon XL (1500, 2500)
Hummer AWD: 2002 - 09 H2; 2006 - 10 H3, H3T

86376 (Alignment) & 86326 (Replacement Pins)

Upper Arm: **Chevrolet/GMC RWD/4WD:** 2011 & Up 2500HD, 3500HD, 4500
Lower Arm: **Chevrolet RWD/4WD:** 2015 & Up Colorado
GMC RWD/4WD: 2015 & Up Canyon

GM REPLACEMENT FRONT PLATE AND CAM **86375, 86376**

The 86375 kit is a stock OE replacement cam/bolt kit for newer GM 1/2, 3/4, and 1 ton truck applications. The 86376 kit is a stock OE replacement cam/bolt kit for newer GM Heavy Duty applications. These kits are for camber and caster adjustment. Fast, simple installation.



WE GO INTERNATIONAL!!!
Go online for region specific and international Off-Road Solutions

DMax
Front
Upper
Arms



Ford Suspension Tuning

Front Adjustment range (Fixed):

23268 Camber $+0.50^\circ$ Caster $+2.3^\circ$

23269 Camber $+0.30^\circ$ Caster $+2.6^\circ$

Installation time: .5 hr/side

Required.: 1 per wheel

APPLICATIONS

Ford RWD/4WD:

2005 & Up F250, F350 Solid Axle, Coil Spring

2005 & Up F450 With 8 Lug Axles

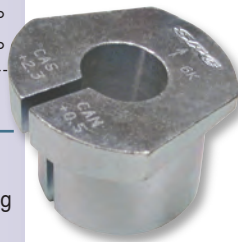

FIXED CHANGE FORD SUPER DUTY SLEEVES

These sleeves have a fixed positive camber and caster change and are designed specifically to align trucks that have been lifted or to provide more caster change than our 23220 series.

For maximum drivability and to compensate for road crown, use a 23268 on the driver's side and a 23269 on the passenger's side.

86250 **Front** Adjustment range:

Camber $\pm 1.00^\circ$ Caster $\pm 1.50^\circ$

Installation time: .3 hr/side

Required.: 1 per wheel

APPLICATIONS

Ford RWD/4WD:

2007 & Up Expedition

2004 & Up F150

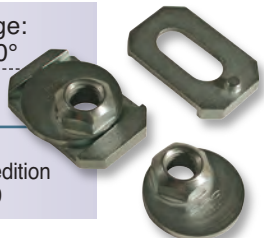

FORD ADJUSTABLE CAM NUT/BRACKET

The innovative cam nut and sturdy bracket saves time and money. Easily adjust camber and caster on F150's and Expeditions. Save time since you don't have to remove the OE bolt or stabilizer bar. The sturdy guide bracket allows for live adjustment. This product is a must have every time these vehicles enter your shop!

86252 **Front** Adjustment range:

Camber $\pm 1.00^\circ$ Caster $\pm 1.50^\circ$

Installation time: .8 hr/side

Required.: 1 per wheel

APPLICATIONS

Ford RWD/4WD:

2007 & Up Expedition

2004 - 14 F150, Raptor



RAPTOR & F150 HD CAM FRONT CAM/CAS KIT

This heavy-duty cam-bolt kit was specifically designed for the extreme Raptor and F-150 user. Whether you are an energetic Raptor driver or abuse your F-150 in the fields and on the job site, you may have found that the OE bolts slip or that a single cam option does not hold alignment. This upgraded cam kit features two cams and bosses per bolt and 12.9 grade hardware. The two cams will keep your bolt square and make adjustment easier while the 12.9 grade bolt and low friction finish achieve 25% more clamp load than the OE hardware. Some drilling is required to accommodate the second boss plate. This kit is sold per wheel and fits Raptors, non-Raptor F-150's and related SUVs.

86255 **Rear** Adjustment range:

Pinion $\pm 2.50^\circ$

Installation time: .5 hr/axle

Required.: 1 per axle

APPLICATIONS

Ford: 2004 & Up F150



F150 PINION ANGLE SHIMS

This wedge-type shim fits the 2 hole design of this platform between the rear spring and the axle to change pinion angle. Perfect to align the driveline on vehicles that have been lowered or lifted.

87385 **Front** Adjustment range:

Camber $\pm 2.00^\circ$ /Caster $\pm 2.00^\circ$

Installation time: .4 hr/side

Required.: 1 per axle

APPLICATIONS

Ford RWD/4WD:

1997 - 02 Expedition

1997 - 03 F150; 2004 - 05 F150 Heritage

1997 - 99 250 (LD)



F150/F250 (L/D) CAMBER/CASTER KIT (4)

Use this kit to change caster and/or camber on these unadjustable vehicles. Simply replace the existing upper control arm mounting bolts with these cam bolts for caster/ camber changes up to 2.0° .



Ford T6 Front Control Arms



WE HAVE TRUCK SLEEVES!

Do you have an older Ford F100 or a newer F250 or F350? Go online or check our Sourcebook for our truck sleeves. We have truck sleeves that fit many Ford Truck/SUV applications!

Off-Road Suspension

Off-Road Suspension

Nissan Suspension Tuning

NISSAN FRONT UPPER ARMS (PR)

Nissans often run out of factory adjustment when lift kits are installed. Additionally, the OEM upper control arm can contact the frame, limiting droop travel and causing unwanted noise vibration harshness. These heavy duty replacement arms feature drawn over mandrel tubing or fully forged construction and use our patented adjustable ball joint and new SpecRide™ bushings, allowing for greatly increased droop travel and easy alignment.

NOTE: Need new bolts on your Frontier, Pathfinder or Xterra? Order #21035 for four replacement bolts.



Patent No. US 7,513,514 B



25540



25560

25540 Front Adjustment range:
Camber $\pm 2.00^\circ$
Caster $+1.00^\circ$ to $+3.00^\circ$
Installation time: .8 hr/side
Required: 1 per axle

APPLICATIONS

Nissan: 2005 & Up Frontier
2005 - 12 Pathfinder
2005 & Up Xterra

25560 Front Adjustment range:
Camber $\pm 2.00^\circ$
Caster $+1.00^\circ$ to $+3.00^\circ$
Installation time: .8 hr/side
Required: 1 per axle

APPLICATIONS

Nissan: 2004 & Up Armada, Titan

These arms feature our SpecRide™ bushings for a quieter, OEM style ride.

NISSAN CAM/CAS SHIMS

These shims install between the upper control arm mount and shaft to adjust Pathfinders and Pickups. 6 Shims per package



35080 - 1mm **35081** - 2mm **35082** - 4mm
Adjustment range: 1mm to 4mm Install time: .3 hr/side

APPLICATIONS

Nissan RWD/4WD: 1987 - 95 Pathfinder; 1986 - 97 Pickup

NISSAN CAMBER/ CASTER KIT (2)

These cams are designed to install in the lower control arms for camber and caster adjustment. They replace the original non-adjustable lower control arm bolts.



87520 Front Adjustment range:
Camber $\pm 2.00^\circ$ /Caster $\pm 2.00^\circ$
Installation time: .3 hr/side Req.: 1 per wheel

APPLICATIONS

Nissan RWD/4WD: 2004 & Up Armada, Titan
2005 & Up Frontier, Xterra; 2005 - 12 Pathfinder

NISSAN CAM KIT

Replace siezed or damaged factory cams on 1998 - 2004 Nissan Frontier front upper control arms with this replacement kit and get $\pm 2.00^\circ$ of camber and caster adjustment.



87520 Front Adjustment range:
Camber $\pm 2.00^\circ$ /Caster $\pm 2.00^\circ$
Installation time: .5 hr/side Req.: 1 per wheel

APPLICATIONS

Nissan: 1998 - 04 Frontier



SPC PERFORMANCE